

SB

Brace Frame

Instructions for Assembly and Use – standard configuration – Version 2.0

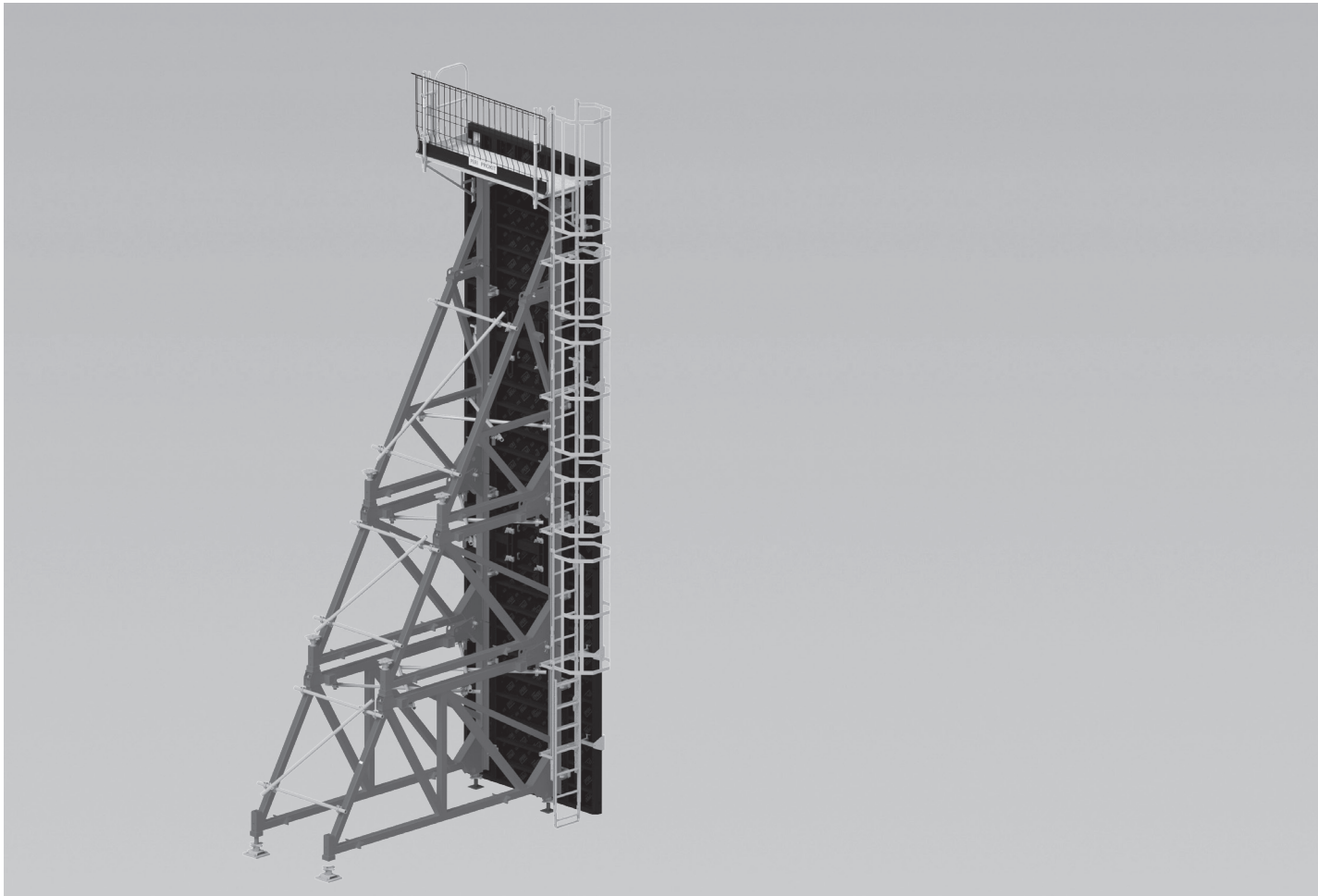

Overview

Main components	4
Key	5

Introduction

Target groups	6
Product description	7
Cleaning and maintenance instructions	8
Disposal	8
Additional technical documentation	9
Instructions for Use	9
RFID transponder	9

Safety instructions

Cross-system	10
System-specific	12
Anchoring	12
Storage and transportation	12
Component list and tightening torques	14
List of components	14
Tool list	15
Tightening torques	15

General information

A1 System overview	16
A2 Storage and transportation	20
A3 Tie technology	22
Tie System DW 15, DW 20, DW 26	22
Version with anchor waler	24
Version with Double Anchor Tie Yoke DSW	25
Standard configurations for civil engineering	26
Standard configuration for rock anchor	26
Tie installation with V-Tie Holder for DW 15, 20, 26	27

Standard configuration SB-A0, A, B, C

B1 Pre-assembly	29
Assembling SB-A0, A, B, C	29
B2 Connecting to systems SB-A0, A, B, C	31
General information	31
Girder Formwork VARIO GT 24, RUNDFLEX and RUNDFLEX Plus-2	31
Combination table	32
Panel formwork	39
MAXIMO, TRIO, DOMINO	39
Assembly	40
MAXIMO combination table	42
TRIO combination table	45
B3 Bracing SB-A0, A, B, C	48
Diagonal bracing	48
B4 Moving	50
With a crane	50
With Guide Roller SB-A0,A,B	51

Standard configuration SB-2

C1 Connecting to system SB-2	52
General information	52
Girder formwork	52
VARIO GT 24, RUNDFLEX	52
MAXIMO, TRIO, DOMINO	54
MAXIMO, TRIO, DOMINO	57
C2 Repositioning with the crane	58

Standard configuration for civil engineering

D1 SB VARIOKIT	60
Pre-assembly	60
Assembling the formwork	61
Anchoring	62
Moving	63
Application	64
D2 SB SCS	65
Pre-assembly	65
Anchoring	66
Moving	67
Application	67

Application

E1 Shuttering	68
E2 Deshuttering	69
Releasing Tie System DW 15	69
Releasing Tie System DW 20	69
Releasing Tie System DW 26	70
Moving the unit	71
E3 Disassembly	72
SB-A0, A, B, C	72
SB-2	73

Special application

F1 Inside corners	74
Application	74
F2 Use as horizontal heavy-duty console bracket	75
Fitting the leading tie	76
Single suspension with Suspension Shoe SB	78
Double suspension with Suspension Shoe SB double	82
System Components SB	86

Main components

Section B1 + B3

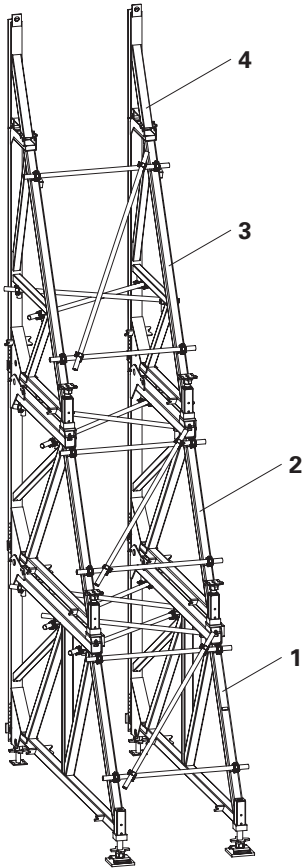

Section C1

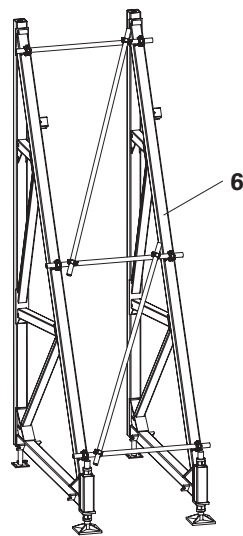

Section D1 + D2

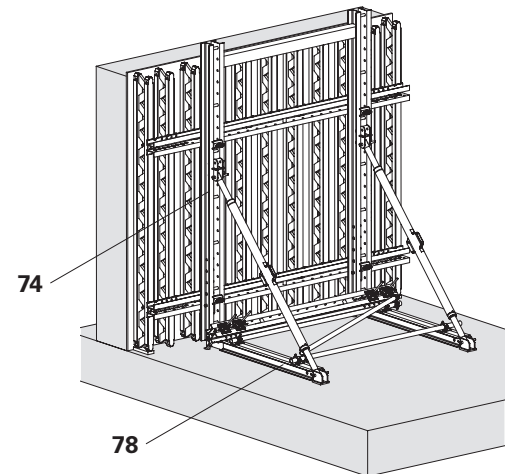
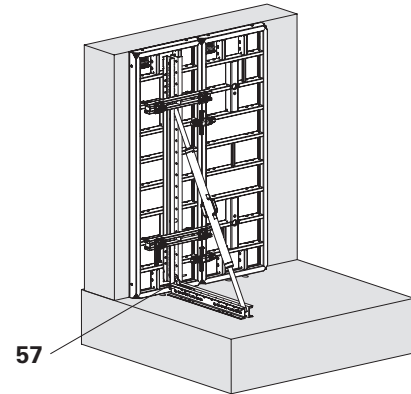

- B1 Pre-assembly
- B3 Bracing SB-A0, A, B, C
- C1 Connecting to system SB-2
- D1 SB VARIOKIT
- D2 SB SCS

- 1** Brace Frame SB-A0
- 2** Brace Frame SB-A
- 3** Brace Frame SB-B
- 4** Brace Frame SB-C

- 6** Brace Frame SB-2

- 57** Corner Connector VARIOKIT SRU
- 74** Strongback SCS 325
- 78** Starter Bar SCS

Key

Pictogram | Definition

 Danger/Warning/Caution

 Note

 To be complied with

 Load-bearing point

 Visual inspection

 Tip

 Incorrect use

 Safety helmet

 Safety shoes

 Safety gloves

 Safety goggles

 Personal protective equipment to prevent falling from a height (PPE)

 Observe additional documentation

Arrows

 Arrow representing an action

 Arrow representing a reaction of an action*

 Arrow representing forces

* If not identical to the action arrow.

Safety instruction categories

The safety instructions alert site personnel to the risks involved and provide information on how to avoid these risks. Safety instructions can be found at the beginning of the section or before instructions for action and are highlighted as follows:

Danger

This sign indicates an extremely hazardous situation that could result in death or serious, irreversible injury if the safety instructions are not followed.

Warning

This sign indicates a hazardous situation that could result in death or serious irreversible injury if the safety instructions are not followed.

Caution

This sign indicates a hazardous situation that could result in minor or moderate injury if the safety instructions are not followed.

Note

This sign indicates situations in which failure to observe the information can result in material damage.

Format of the safety instructions

Signal word

Type and source of hazard!
Consequences of non-compliance.
⇒ Preventative measures.

Dimensions

Dimensions are usually given in cm. Other measurement units, e.g. m, are shown in the illustrations.

Conventions

- Instructions are numbered with: 1., 2., 3.
- The result of an instruction is shown by: →
- Position numbers are clearly provided for the individual components and are given in the drawing, e.g. **1**, in the text in brackets, for example **(1)**.
- Multiple position numbers, i.e. alternative components, are represented with a slash: e.g. **1/2**.

Notes on illustrations

The illustration on the front cover of these instructions is understood to be a system representation only. The assembly steps presented in these Instructions for Assembly and Use are shown in the form of examples with only one component size. They are valid for all component sizes contained in the standard configuration.

To facilitate understanding, detailed illustrations are sometimes incomplete. The safety equipment that might not be shown in these detailed illustrations must nevertheless be available.

Target groups

Contractors

These Instructions for Assembly and Use are designed for contractors who either

- assemble, modify and dismantle PERI systems, or
- use them, e.g. for concreting, or
- allow them to be used for other operations, e.g. carpentry or electrical work.

Safety and Health Protection Coordinator*

- is appointed by the client,
- must identify potential hazards during the planning phase,
- determines measures that provide protection against risks,
- creates a safety and health protection plan,
- coordinates the protective measures for the contractor and site personnel so that they do not endanger each other,
- monitors compliance with the protective measures.

Competent person

- is appointed by the contractor,
- must be on site for all system operations,
- prepares and updates the plan for assembly, modification and dismantling,
- prepares and updates the plan for use of the system by the user,
- supervises the assembly, modification and dismantling work (supervisor).

Competent persons qualified to carry out inspections

Due to the specialist knowledge gained from professional training, professional experience and recent professional activity, the competent person qualified to carry out inspections has a reliable understanding of safety-related issues and can carry out inspections correctly. Depending on the complexity of the inspection to be undertaken, e.g. scope of testing, type of testing or the use of certain measuring devices, a range of specialist knowledge is necessary.

Qualified personnel

PERI systems may only be assembled, modified or dismantled by personnel who are suitably qualified to do so. Qualified personnel must have completed a course of training** in the work to be performed, covering the following points at least:

- Explanation of the plan for the assembly, modification or dismantling of the system in an understandable form and language.
- Description of the measures for safely assembling, modifying or dismantling the system.
- Naming of the preventive measures to be taken to avoid the risk of persons and objects falling.

- Designation of the safety precautions in the event of changing weather conditions that could adversely affect the safety of the system, as well as the personnel concerned.
- Details regarding permissible loads.
- Description of all other risks and dangers associated with assembly, modification or dismantling operations.



- **Ensure that the relevant national guidelines and regulations in the respective current version are complied with!**
- **If no country-specific regulations are available, PERI recommends that you proceed according to German guidelines and regulations.**

* Valid in Germany e.g.: Regulations for Occupational Health and Safety on Construction Sites 30 (RAB 30).

** Instructions are given by the contractor themselves or a competent person selected by them.

Product description

Intended use

PERI products have been designed for exclusive use in the industrial and commercial sectors by suitably trained personnel only.

The SB Brace Frame system is designed for single-sided forming operations on walls, rocks, sheet piling, soil, etc.

The fresh concrete pressure that occurs on the formwork surface must be transferred via a brace frame construction with corresponding anchoring into the ground.

The system consists of several units (steel constructions) that can be used individually or in combination for different heights:

- SB-A0, SB-A, SB-B, SB-C,
- SB-2,
- SB VARIOKIT, SB SCS.

The height of brace frame units is increased by means of integrated connecting parts and match truck or container loading dimensions.

Connection to PERI formwork systems is realised using corresponding connection parts.

There are three different tie systems for tensile anchoring of the occurring forces into the ground.

Use the work platforms from the relevant formwork system.

Features

Concreting heights up to	
Brace Frame SB-A0, A, B, C:	8.75 m
Brace Frame SB-A, B, C:	6.75 m
Brace Frame SB-A, B:	6.00 m
Brace Frame SB-B, C:	5.00 m
Brace Frame SB-A, C:	4.00 m
Brace Frame SB-B:	4.00 m
Brace Frame SB-A:	3.00 m
Brace Frame SB-2:	6.00 m
Brace Frame SB VARIOKIT:	3.00 m
Brace Frame SB SCS:	3.95 m

Technical data

The permissible fresh concrete pressure on vertical formwork depends on the formwork system used and the formwork height.

Standard tie systems

permissible load:

DW 15	90 kN
DW 20	150 kN
DW 26	250 kN

Possibility of connection to MAXIMO, TRIO, DOMINO, RUNDFLEX, RUNDFLEX Plus-2, VARIO GT 24.

For the standard configuration, there are load tables that feature the forces, deformations and influence widths; see PERI Design Information for Brace Frame SB and PERI Design Information for Single-sided SCS Climbing System.

We recommend inclining the Brace Frames SB-A0, A, B, C forward by 2/3 of the calculated deformation.

Ladders and concreting platforms must be selected to suit the formwork system used.

Cleaning and maintenance instructions

In order to maintain the value and operational readiness of the materials over the long term, clean the panels after each use.

Some repair work may also be inevitable due to the tough working conditions.



The contractor must ensure that the personal protective equipment required for cleaning, maintenance and repair work such as

- Safety helmet,
- Safety shoes,
- Safety gloves,
- Safety goggles,

is available and used as intended.

The following instructions should help to keep cleaning and maintenance costs as low as possible.

Cleaning tools must be adapted to the respective surfaces of the components so that they are not damaged.

Spray the formwork on both sides with concrete release agent before each use; this makes the formwork easier and faster to clean.

Spray the concrete release agent very thinly and evenly.

Do not spray work platforms and access routes with concrete release agent.

Slip hazard.

Spray the rear side of the formwork with water immediately after concreting; this avoids any time-consuming and costly cleaning operations.

When used continuously, spray the formlining elements with concrete release agent immediately after striking; then clean by means of a scraper, brush or rubber lip scraper.

Important: do not clean formlining made of plywood with high-pressure equipment. This could result in the formlining being damaged.

Fix recesses and built-in parts with double-headed nails; as a result, the nails can easily be removed later, and damage to the formlining is largely avoided.

Close all unused tie holes with plugs; this eliminates any subsequent cleaning or repair work.

Tie holes accidentally blocked with concrete are cleared by means of a steel pin from the formlining side.

When placing bundles of reinforcement bars or other heavy objects on horizontally stored formwork elements, suitable support, e.g. squared timbers, is to be used: this prevents impressions and damage to the formlining to a large extent.

Internal concrete vibrators should be fitted with rubber caps if possible; as a result, any damage to the formlining is reduced if the internal vibrator is accidentally inserted between the reinforcement and formlining.

Never clean powder-coated components, e.g. elements and accessories, with a steel brush or hard metal scraper; this ensures that the powder coating remains intact. Use spacers for reinforcement with large-sized supports or extensive areas of support; this largely avoids impressions being formed in the formlining when under load.

Mechanical components, e.g. spindles or gear mechanisms, must be cleaned of dirt or concrete residue before and after use, and then greased with a suitable lubricant.

Provide suitable support for the components during cleaning so that no unintentional change in their position is possible.

Do not clean components suspended on crane lifting gear.

Disposal

Carry out disposal in accordance with the relevant national regulations.

Observe the safety data sheets of the auxiliary and operating materials.

Additional technical documentation

- PERI Structural Design Information
 - Brace Frame SB
 - SCS Single-sided Climbing System
- Translation of Original Instructions for Use:
 - Lifting Hook MAXIMO 1.5 t
 - Lifting Hook DOMINO
 - Climbing Beam 9 t
 - Rock Anchor DW HB 15
- User information:
 - Pallets and stacking devices
- PERI Design Tables 2015 – Formwork and Shoring
- Product brochure:
 - SB Brace Frame
- Approvals
 - Tie bolt: Z-21.8-2115
 - Climbing Cone-2: Z-21.6-1767
 - Rock anchor: Z-21.6-1778
 - Tie Rod DW: Z-12.5-96

Instructions for Use

Use in a way not intended, deviating from the standard configuration or the intended use according to the Instructions for Assembly and Use, represents a misapplication with a potential safety risk, e.g. risk of falling.

Only PERI original components may be used. The use of other products and spare parts is not allowed and represents a misapplication with associated safety risks.

Changes to PERI components are not permitted.

The system described in these Instructions for Assembly and Use may contain patent-protected components.

Additional wind attack surfaces due to icing are not taken into account. Snow and ice loads are not taken into account.

RFID transponder

Individual components are equipped with an RFID transponder. RFID transponders combine hardware with additional software to create a smart product. Depending on the component and digital solution, this makes it possible to:

- Open technical documents.
- View maintenance plans.
- Track information on transport and logistics.



For more information, see “RFID LA Tag Mounting Kit User Information”.

Cross-system



Safety instructions apply to all service life phases of the system.

General information

The contractor must ensure that the Instructions for Assembly and Use supplied by PERI are available at all times and understood by the site personnel.

These Instructions for Assembly and Use can be used as the basis for creating a risk assessment. The risk assessment is compiled by the contractor. The Instructions for Assembly and Use are not a substitute for a risk assessment!

Observe and comply with the safety instructions and permissible loads.

For the application and inspection of PERI products, observe the current laws and regulations in force in the respective countries.

Materials and working areas are to be inspected before each use and assembly for:

- damage,
- stability and
- functional correctness.

Damaged components must be exchanged immediately on site and no longer be used.

Safety components are to be removed only when they are no longer required.

When on slab formwork, scaffolds and working platforms:

- do not jump,
- do not run,
- do not drop anything from or onto it.

Components provided by the contractor must comply with the characteristics stipulated in these Instructions for Assembly and Use and all applicable laws and standards. Unless otherwise indicated, the following applies in particular:

- Timber components:
Strength class C24 for solid wood according to DIN EN 338:2016-07.
- Scaffolding tubes:
Galvanised steel tubes with minimum dimension \varnothing 48.3 x 3.2 mm according to DIN EN 12811-1:2004-03 4.2.1.2.
- Scaffolding tube couplings:
according to DIN EN 74-1:2022-09 and DIN EN 74-2:2022-09.

Deviations from the standard configuration are only permitted after a further risk assessment has been carried out by the contractor.

Appropriate measures for working and operational safety, as well as stability, are defined on the basis of this risk assessment.

Corresponding proof of stability can be provided by PERI on request if the risk assessment and resulting measures to be implemented are made available.

Nails and wood screws must not protrude. Only allow other connecting components to protrude to the extent that is necessary. If necessary, mark protruding components or fit them with protective material.

Secure all bolts with cotter pins and all screws with nuts.

Before and after extraordinary events that may have damaging effects on the safety of the system, the contractor must immediately

- produce another risk assessment, the results of which must be used to implement suitable measures to ensure the stability of the system,
- arrange for an extraordinary inspection to be carried out by a competent person qualified to do so. The aim of this inspection is to detect and repair damage in good time in order to ensure the safe use of the system.

Exceptional events could be:

- accidents, fire, explosions, collisions,
- long periods of non-use,
- natural events, e.g. heavy rainfall, heavy snowfall, significant icing, storms or earthquakes.

Suitable measures could be:

- removing nets/tarpaulin.
- clearing snow and ice.
- reducing live loads.
- securing loose materials.

Assembly, modification and dismantling work

PERI systems may only be assembled, modified or dismantled under the supervision of a person qualified to do so and by technically suitable employees. The qualified personnel must have received appropriate training for the work to be carried out with regard to specific risks and dangers.

On the basis of the risk assessment and Instructions for Assembly and Use, the contractor must create installation instructions, in order to guarantee safe assembly, modification and dismantling of the system units.



The contractor must ensure that the personal protective equipment required for the assembly, modification or dismantling of the system, e.g.

- Safety helmet,
- Safety shoes,
- Safety gloves,
- Safety goggles,

is available and used as intended.

For work at a higher level, use an approved ladder or platform system, or an assembly scaffold.



If personal protective equipment against falling from a height (PPE) is required or specified in local regulations, the contractor must determine appropriate attachment points on the basis of the risk assessment.

The PPE to be used to prevent falling is determined by the contractor.

The contractor must

- provide safe working areas for site personnel, which are to be reached through the provision of safe access ways. cordon off and clearly mark danger zones.
- guarantee stability during all stages of construction, in particular during assembly, modification and dismantling operations.
- ensure and demonstrate that all loads that occur are safely transferred.

Use

Every contractor who uses or allows the PERI systems to be used, is responsible for ensuring that the equipment is in good condition.

If the system is used successively or at the same time by several contractors, the health and safety coordinator must point out any possible mutual hazards and all work must then be coordinated.

When scaffolds are used in publicly accessible areas,

- measures to prevent unauthorised use, e.g. enclosure of access areas, must be taken.
- Measures are taken against injuries caused by bumping against protruding components, e.g. assembly of protective components.

Always keep the contact surfaces of the system free of dirt, objects, snow and ice.

Close off the scaffold in extreme weather conditions.

System-specific



Safety instructions apply to all service life phases of the system.

When using other ties or formwork systems, the potential applications as well as stability must be checked separately by the user.

Deviations always require separate static proof.

Existing walls, shoring, rock etc. must be able to withstand the pressure exerted by the fresh concrete.

Strike components only when the concrete has hardened sufficiently and the person in charge has given the go-ahead for striking to take place.

Only use PERI lifting accessories.

During deshuttering, do not tear off the formwork units with the crane.

If a storm warning is issued, additional push-pull props are to be attached or other bracing measures are to be carried out along with implementing the details contained in the PERI Design Tables.

Anchoring

Anchoring is to take place only if the anchorage has sufficient concrete strength.

Do not weld, heat or deform DW Tie Rods that are to be used for anchoring.

Inspection of the anchoring and associated components must be carried out by the contractor (user).

Storage and transportation

General information

- Store and transport components in such a way that no unintentional change in their position is possible. Detach load-lifting accessories and lifting gear from the lowered components only if they are in a stable position and no unintentional change is possible.
- Do not drop the components.
- Only ever use approved and inspected means of transportation from PERI including lashing, lifting gear and slings.
- Only ever attach the means of transport to the intended attachment points with a positive fit using suitable lifting gear and slings.

During the relocation procedure

- Ensure that components are picked up and set down in such a way that unintentional falling over, falling apart, sliding, falling down or rolling is avoided.
- Always use ropes to guide components or assemblies that are susceptible to wind when moving them with a crane.
- No one is allowed to remain under the suspended load.
- The access areas on the construction site must be free of obstacles, trip hazards and must also be slip-resistant.
- For transportation, the substrate must have sufficient load-bearing capacity.
- Use original PERI storage and transport systems, e.g. crate pallets, pallets or stacking devices.

Component list and tightening torques



List of components

Pos. no.	Component name	Article no.	Pos. no.	Component name	Article no.
1	Brace Frame SB-A0	025690	43	Sleeve SB/MX ga	114107
2	Brace Frame SB-A	025700	44	Sleeve SB/MX WDMX	114417
3	Brace Frame SB-B	025710	45	Pin SB/TR,D ga	027690
4	Brace Frame SB-C	025720	46	Scaffolding tube Ø48.3x3.2 mm	–
5	V-Tie Holder DW15	031580	47	Swivel Coupler SW Ø48/48 mm ga	017010
6	Brace Frame SB-2	027510	48	Guide Roller SB-A0,A,B	025750
7	Wingnut DW15 ga	030100	49	Hook Strap SB-2 asymmetric	116078
8	Double Anchor Tie Yoke DSW	027520	50	Connection Rail SB-2/TR,MX,D	027680
9	Tie Rod DW15, spec. length	030030	51	Board 3 x 14	–
10	Hex-Nut DW15 SW30 108 mm ga	030090	52	Compensation Waler-3 MAR 85	124941
11	Anchorage Loop DW15	030060	53	Hook Tie Head DW15	023820
12	Threaded Anchor Plate DW15	030840	54	Steel Waler SRU 247 U120	103892
13	Wingnut Pivot Plate DW15 ga	030370	55	Steel Waler SRU 122 U120	103874
14	Anchor Plate SB DW26	027480	56	Heavy Duty Spindle SLS 140-240	101776
15	Anchor Waler 55 U140	027650	57	Corner Connector VARIOKIT SRU	115623
16	Anchor Waler 235 U140	027530	58	Fitting Pin Ø21x120 mm	104031
17	Wingnut DW20 ga	030990	59	Cotter Pin 4/1 ga	018060
18	Counterplate DW20 120x120x20 mm	030830	60	Waler 85	023551
19	Anchor Waler 55 U160	109017	61	Hook Tie Head DW15 ga	023820
20	Tie Rod DW20, spec. length	030700	62	Suspension Shoe SB	106661
21	Hex-Nut DW20 SW36 110 mm weldab	030590	63	Brace Frame Adaptor SB-A0,A,B	106662
22	Threaded Anchor Plate DW20	030860	64	Climbing Cone-2 DW26 M36 ga	030940
23	Hex-Nut DW26 SW46 80 mm ga	030970	65	Scaff. Mount. Ring M36 galv	029490
24	Anchor Rele. Plate SB DW26 cpl	101621	66	Screw ISO 4014-M36x130-10.9	029550
25	Tie Rod DW26, spec. length	030340	67	Brace Frame Adaptor SB-2	106663
26	Hex-Nut DW26 SW46 150 mm weldab	030980	68	Suspension Shoe SB double	111866
27	Threaded Anchor Plate DW26	030870	69	Anchor Posit. Plate M36 ga	029390
28	Lead. Anchor Coupler DW15 cpl	031631	70	Screw ISO 4017-M36x070-8.8-ga	029430
29	Spacer Tube Ø32 mm 300 rough	031627	71	Hex-Wood-Screw 6x20 DIN 571-ga	029440
30	Lead. Anchor Coupler DW20 cpl	031632	72	Anchor Posit. Stud M36 ga	026460
31	V-Tie Holder DW20	031590	73	Wire Nail 3.0x80 mm	710312
32	Spacer Tube Ø42 mm 300 rough	031634	74	Strongback SCS 325	118584
33	Lead. Anchor Coupler DW26 cpl	031633	75	Spindle Connector SCS Ø26/21 mm	118580
34	V-Tie Holder DW26	031600	76	Height Adjusting Unit CB SCS	051030
35	Waler Connector SB-A0,A,B,C	025760	77	Waler Fixation U100/U120	110059
36	Wedge K ga	024250	78	Starter Bar SCS	118799
37	Round sling	–	79	Anchor Bolt SW24 Ø14/20x130 mm	124777
38	Hook Strap SB-2 ga	027590	80	Tie Yoke SCS Ø60 mm 200 mm	124630
39	Distribution waler	–	81	Heavy-Duty Spindle SCS 198-250	118585
40	Connector SB/RFP	109587	83	Heavy Duty Spindle SLS 260-360	101779
41	Connector SB-A0,A,B,C/TR,MX,D	025740	84	Spindle Adapter SLS/RCS	110477
42	Pin SB/MX ga	113255	85	Adjusting Unit SRU internal	111135

Component list and tightening torques

Pos. no.	Component name	Article no.	Pos. no.	Component name	Article no.
86	Counterplate RCS DW20	114082	88	Fitting Pin Ø26x120 mm	111567
87	Reducing Sleeve Ø26/Ø21 mm ga	129695	89	Cotter Pin 5/1 ga	022230

Tab. 01

Tool list

Tool name	Article number
Hexag. Recess Wrench SW14 long	027212
Open-End Wrench SW80 for SB	027210
Open-End Wrench SW70	027213
Open-End Wrench SW46 for SB	027211
Open-End Wrench SW36	138686
Open-End Wrench SW30	138687
Tens. Rod Spanner DW20/26 ga	031490

Tab. 02

Tightening torques

Unless otherwise indicated, PERI recommends the following guide values for screw connections as "hand-tightened" tightening torques $M_{A,hand-tightened}$. These guide values are based on EN 15048 with minimum Safety Factor 3 against breakage.

Quality class	Quality 4.6		Quality 8.8 and 10.9
	Lightly oiled	MoS2	Undefined
Screw M8	8 Nm	6.6 Nm	8 Nm
Screw M10	16 Nm	13.0 Nm	16 Nm
Screw M12	30 Nm	23.0 Nm	30 Nm
Screw M16	65 Nm	54.0 Nm	65 Nm
Screw M20	100 Nm		100 Nm
Screw M24	150 Nm		150 Nm
Screw M30	260 Nm		260 Nm
Screw M36	350 Nm		350 Nm

Tightening torques have been determined for the following components:

Scaffolding tube coupling	50 Nm
---------------------------	-------

Tab. 03

Application possibilities

The Brace Frame SB is used for vertical load transfer as standard.

Alternatively, and depending on the project in question, the Brace Frame SB can also be used for horizontal load transfer.

It is available as a single-frame SB-2 and as a modular frame system SB-A0, SB-A, SB-B and SB-C.

In addition, the Brace Frame SB VARIOKIT and Brace Frame SB SCS can also be installed using VARIOKIT and SCS components.

When concreting single-sided walls, the concrete pressure that occurs is diverted into the substructure. The SB Brace Frames can be combined with all wall formwork systems.

When concreting cantilevered slabs or pier heads, the brace frame can be used horizontally as a heavy-duty console bracket.



All of the following variants are execution examples.

Variant 1:

Use as formwork with Brace Frame SB-A, B, C.

- VARIO GT 24 Girder Wall Formwork.
- Concreting platform with Scaffold Bracket GB 80.

Components

- A** Brace frame
- B** Formwork
- C** Anchoring
- E** Concreting platform

- 2** Brace Frame SB-A
- 3** Brace Frame SB-B
- 4** Brace Frame SB-C
- 35** Waler Connector SB-A0,A,B,C

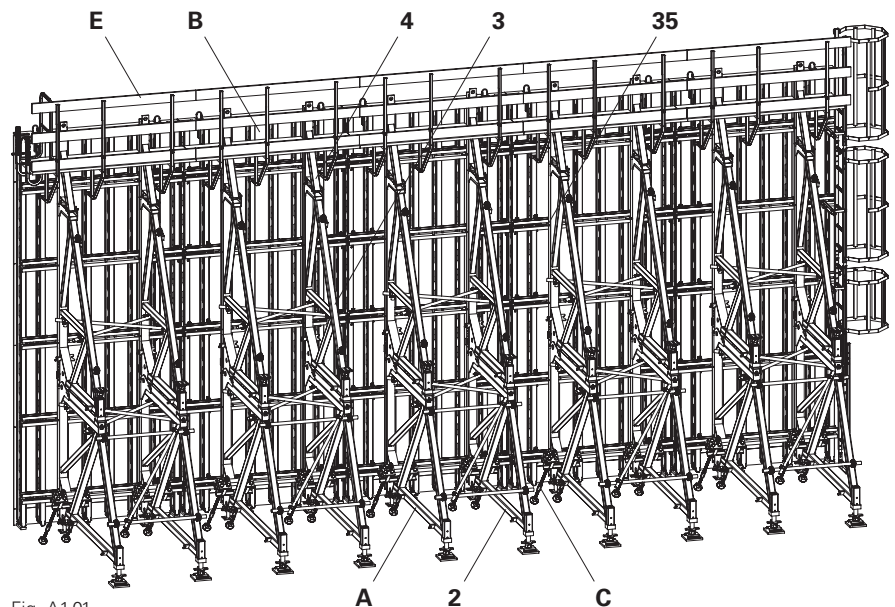

Fig. A1.01

Variant 2:

Use as formwork with Brace Frame SB-B.

- MAXIMO Panel Formwork.

Components

- A** Brace frame
- B** Formwork
- C** Anchoring

- 3** Brace Frame SB-B
- 41** Connector SB-A0,A,B,C/TR,MX,D

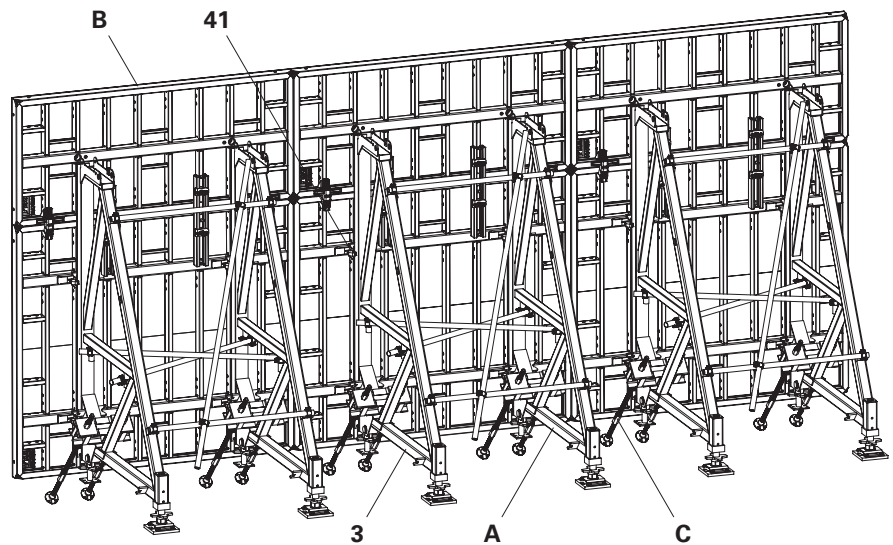

Fig. A1.02

Variant 3:

Working platform with Brace Frame
SB-A0, A, B.

- Suspension Shoe SB double.
- Platform with Girder VT 20K.
- Guardrail with guardrail boards.

Components

A Brace frame

D Suspension

1 Brace Frame SB-A0

2 Brace Frame SB-A

3 Brace Frame SB-B

4 Brace Frame SB-C

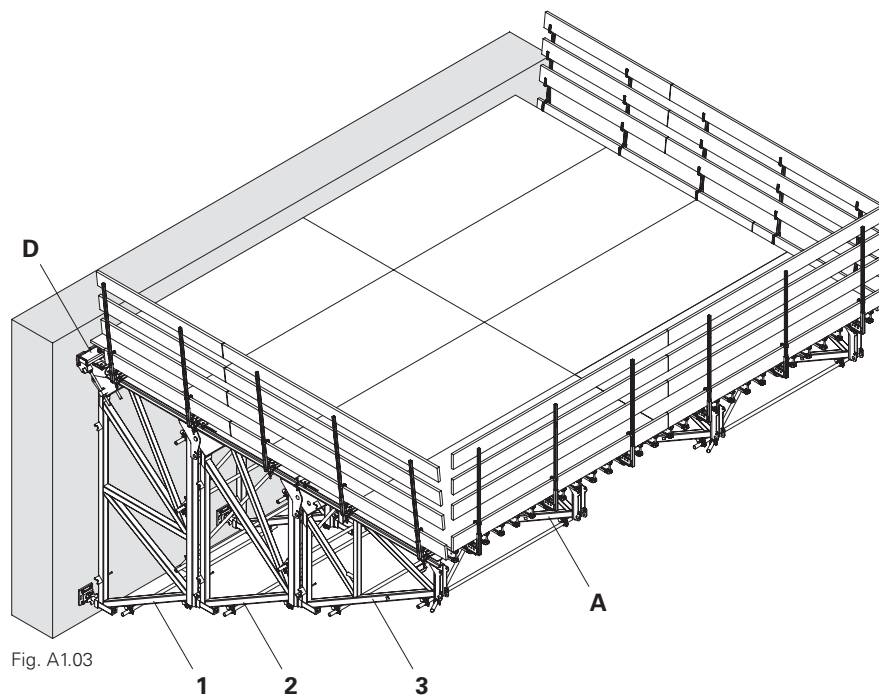

Fig. A1.03

Variant 4:

Platform for pier formwork with
Brace Frame SB-A0, A, B.

- Suspension Shoe SB double.
- VARIO GT24 Girder Wall Formwork.
- Platform with Formwork Girder GT 24 and Steel Walers SRU U120.
- Guardrail with guardrail boards.

Components

A Brace frame
B Formwork
E Concreting platform

- 1** Brace Frame SB-A0
2 Brace Frame SB-A
3 Brace Frame SB-B

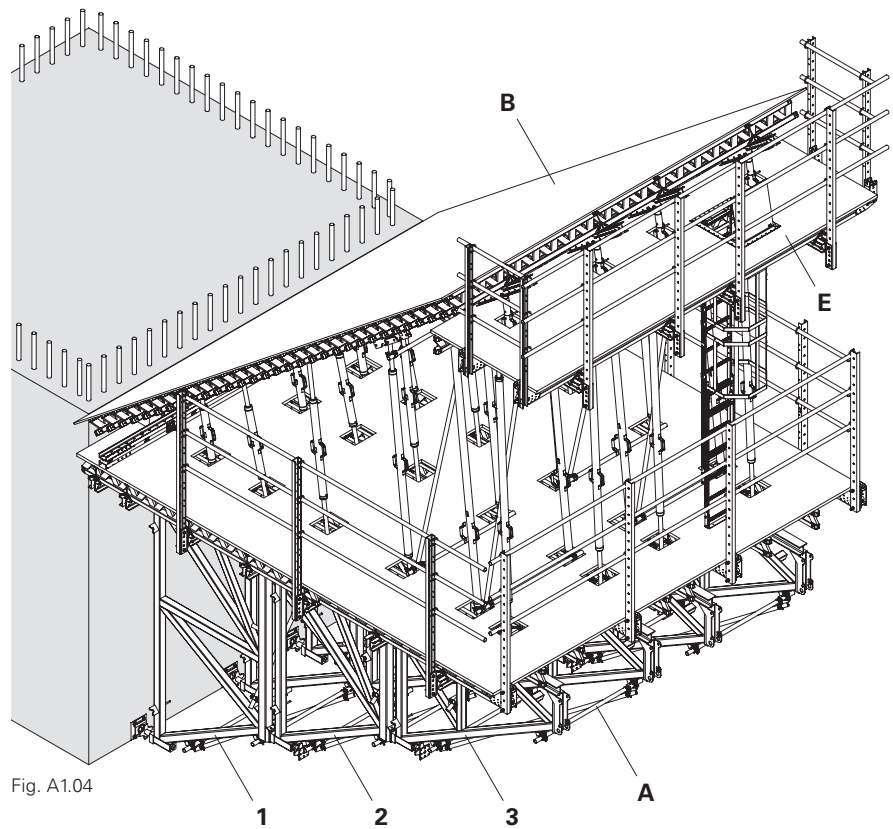

Fig. A1.04



Warning

Components may fall down!

This can lead to serious injuries or even death.

- ⇒ Secure or remove loose parts.
- ⇒ Do not stand under the suspended load.



- Refer to the user information for PERI pallets and stacking devices!
- Follow PERI packaging guidelines!
- Transportation units must be correctly stacked and secured!

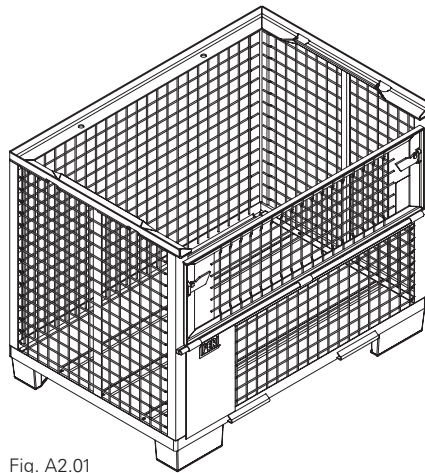

Fig. A2.01

Transportation

PERI pallets and stacking devices are suitable for lifting by crane or forklift. They can also be moved with the PERI pallet lifting trolley.

All pallets and stacking devices can be lifted using both the longitudinal and front sides.

(Fig. A2.01)

Stacking



- Only brace frame units of the same size are to be transported in one stack.
- Lash the stacking units together.
- Secure material, take country-specific regulations into consideration.

Stack height:

max. 6 units depending on the truck.

(Fig. A2.02)

10 units for Brace Frame SB-C

(not shown)

- Use integrated stacking aid (1.1) on the brace frame units. (Fig. A2.02a)
- Support tubes (1.8) must be at the bottom.

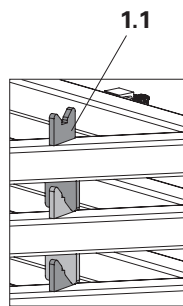

Fig. A2.02a

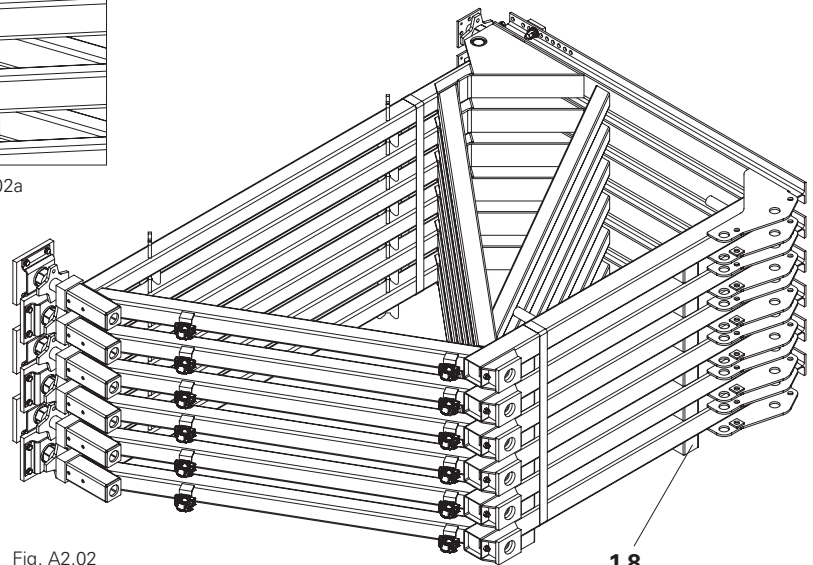

Fig. A2.02

1.8



- Have the loading process carried out and checked by the appropriate specialist departments.
- The number of stacks that can be transported depends on the respective national transport regulations.

Loading onto trucks

- Secure stacks with steel strapping.
- Secure stacks with tension belts.
Use edge protection.
- Max. height of 2 stacks, each with 6 brace frames.

(Fig. A2.03)

Loading example

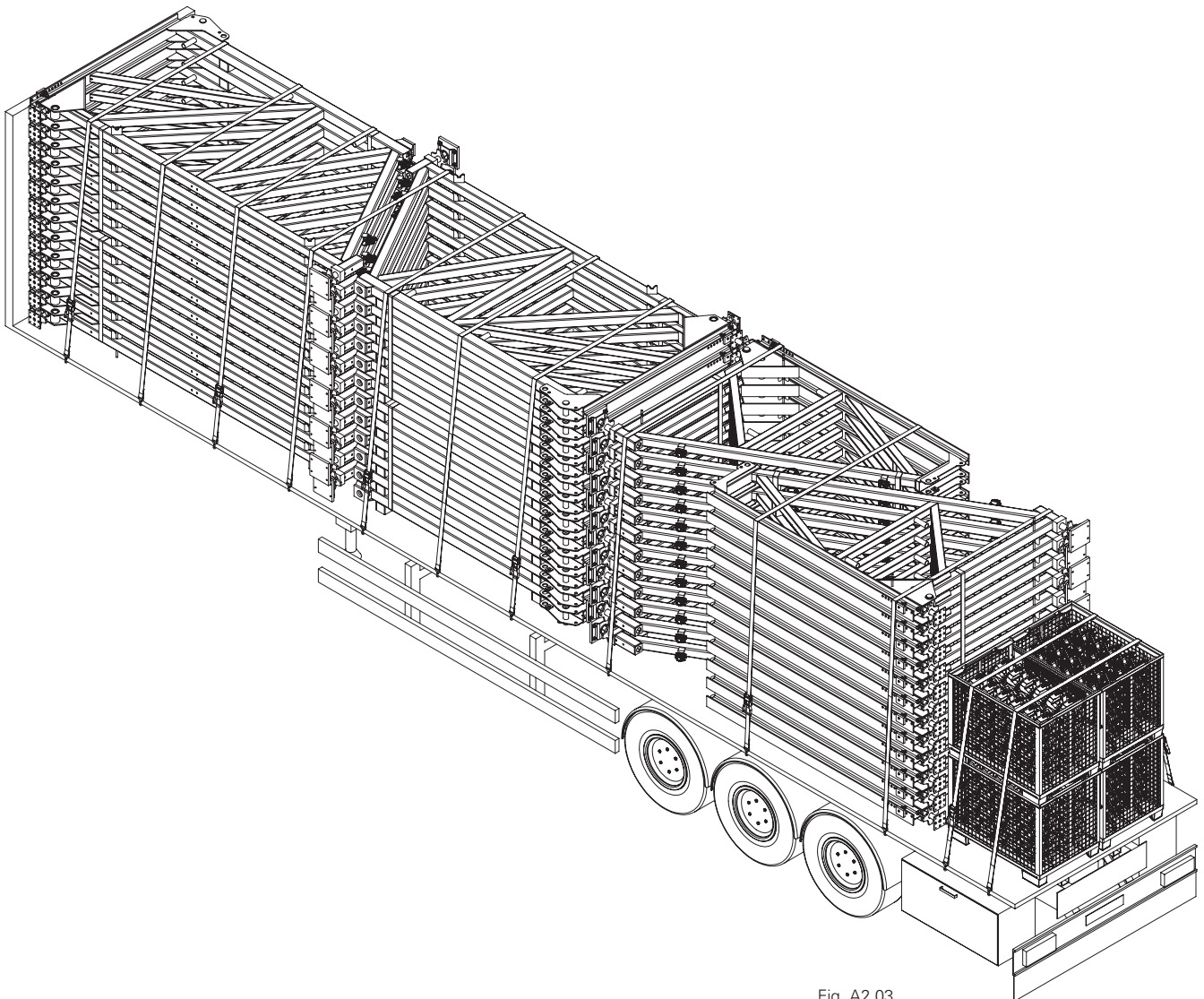

Fig. A2.03

Tie System DW 15, DW 20, DW 26

- Other anchoring systems than those shown here require separate static proof!
- Dimensions in mm.

Tie System DW 15 Version with double tie yoke

Permissible tension force $2 \times 90 \text{ kN} = 180 \text{ kN}$.

Reusable tie parts:

7 Wingnut DW15 ga	2x
8 Double Anchor Tie Yoke DSW	1x
9 Tie Rod DW15	2x
10 Hex-Nut DW15 SW30 108 mm ga	2x

Lost tie parts:

11 Anchorage Loop DW15 Alternatively, see Fig. A3.03	1x
9 Tie Rod DW15	2x
12 Threaded Anchor Plate DW15	2x

(Fig. A3.01)

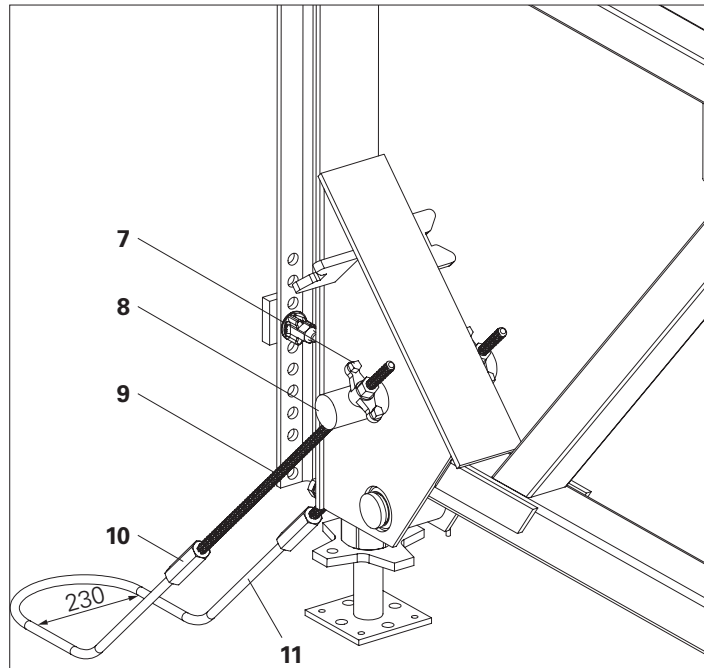

Fig. A3.01

Tie System DW 15 Version with anchor waler

Permissible tension force $2 \times 90 \text{ kN} = 180 \text{ kN}$.

Reusable tie parts:

9 Tie Rod DW15	2x
10 Hex-Nut DW15 SW30 108 mm ga	2x
13 Wingnut Pivot Plate DW15 ga	2x
14 Anchor Plate SB DW26	2x
15 Anchor Waler 55 U140 or	2x
16 Anchor Waler 235 U140	2x

Lost tie parts:

11 Anchorage Loop DW15 Alternatively, see Fig. A3.03	1x
9 Tie Rod DW15	2x
12 Threaded Anchor Plate DW15	2x

(Fig. A3.02)

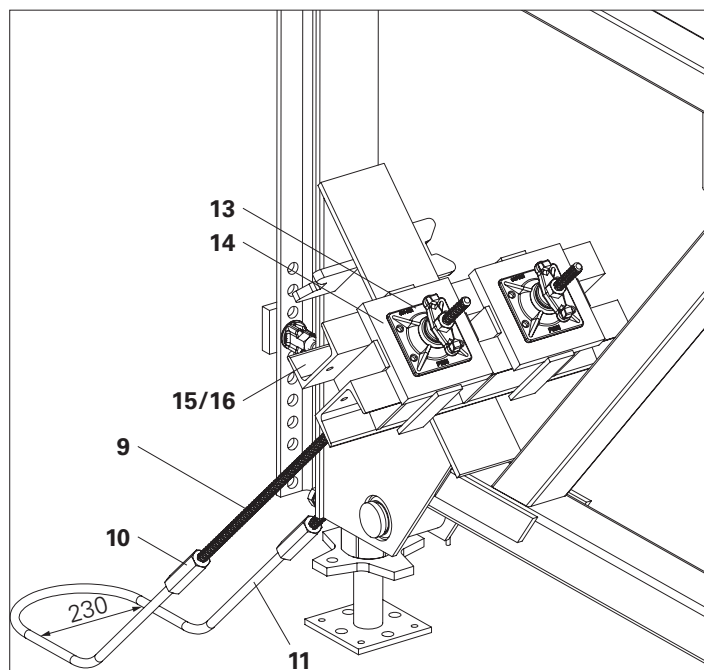

Fig. A3.02

Tie System DW 20

Version with anchor waler

Permissible tension force $2 \times 150 \text{ kN} = 300 \text{ kN}$.

Reusable tie parts:

14	Anchor Plate SB DW26	2x
17	Wingnut DW20 ga	2x
18	Counterplate DW20 120x120x20 mm	2x
19	Anchor Waler 55 U160	2x
20a	Tie Rod DW20	2x
21	Hex-Nut DW20 SW46 110 mm ga	2x

Lost tie parts:

20b	Tie Rod DW20	2x
22	Threaded Anchor Plate DW20	2x
31	V-Tie Holder DW20	2x

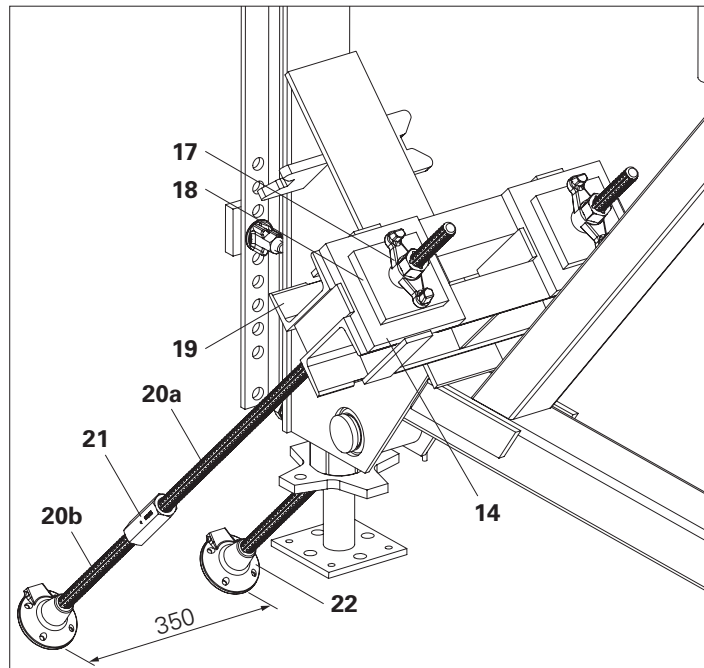

Fig. A3.03

(Fig. A3.03)



- Structure for DW 15 same as corresponding components.
- Spacing 230 mm.
- Permissible tension force $2 \times 90 \text{ kN} = 180 \text{ kN}$.

Tie System DW 26

Version with anchor waler

Permissible tension force $2 \times 250 \text{ kN} = 500 \text{ kN}$.

Reusable tie parts:

19	Anchor Waler 55 U160	2x
23	Hex-Nut DW26 SW46 80 mm ga	2x
24	Anchor Rele. Plate SB DW26	2x
25a	Tie Rod DW26	2x
26	Hex-Nut DW26 SW46 150 mm ga	2x

Lost tie parts:

25b	Tie Rod DW26	2x
27	Threaded Anchor Plate DW26	2x
34	V-Tie Holder DW26	2x

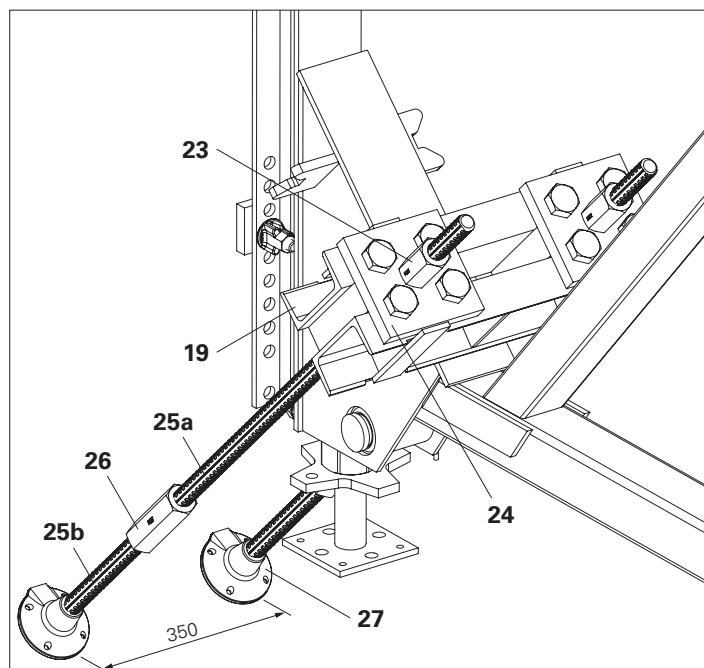

Fig. A3.04

(Fig. A3.04)

Version with anchor waler



Brace Frame SB-A0, A, B

in accordance with the DW tie system
(Fig. A3.05a – Fig. A3.05c)

The given dimensions x and y are ideal values. If the ideal dimension x is adhered to, the anchoring is in the interference-free area behind the formwork.

If x becomes larger, y must become smaller. Project-specific planning required.

$y \leq 315$ mm

All dimensions given in mm.

Framed formwork panel

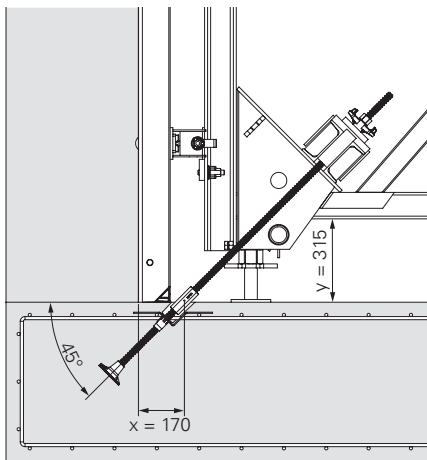

Fig. A3.05a

Girder formwork

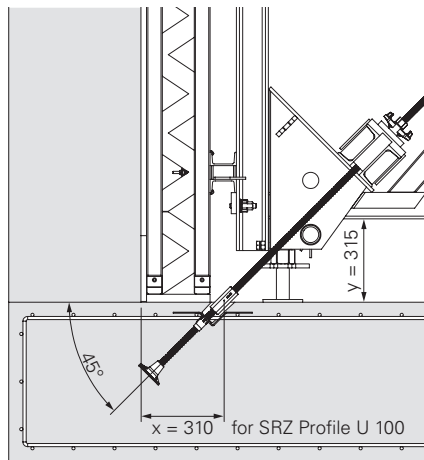

Fig. A3.05b

Girder circular formwork

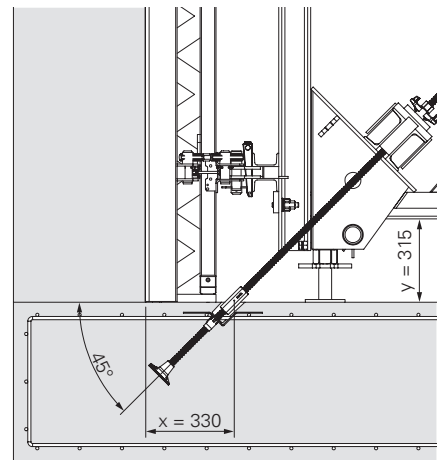

Fig. A3.05c

Brace Frame SB-2

in accordance with the DW tie system
(Fig. A3.06a – Fig. A3.06c)

Framed formwork panel

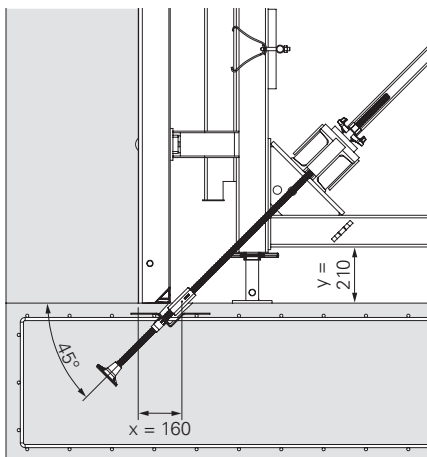

Fig. A3.06a

Girder formwork

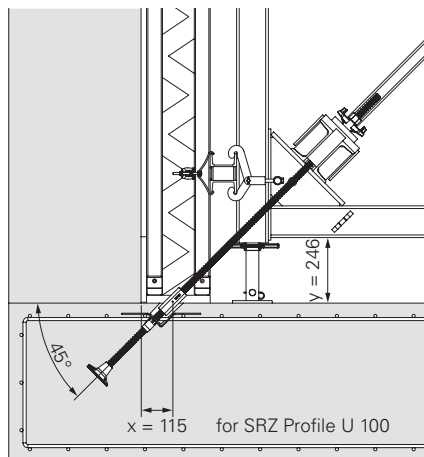

Fig. A3.06b

Girder circular formwork

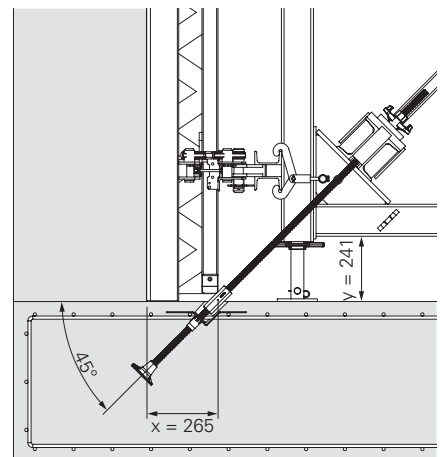

Fig. A3.06c

Version with Double Anchor Tie Yoke DSW



Brace Frame SB-B

in accordance with the DW tie system
(Fig. A3.07a – Fig. A3.07c)

The given dimensions x and y are ideal values. If the ideal dimension x is adhered to, the anchoring is in the interference-free area behind the formwork. If x becomes larger, y must become smaller. Project-specific planning required.
 $y \leq 315$ mm
All dimensions given in mm.

Framed formwork panel

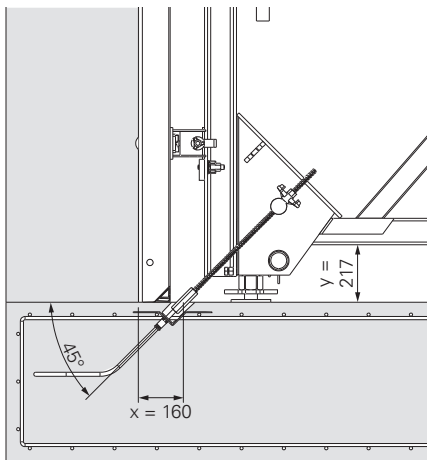

Fig. A3.07a

Girder formwork

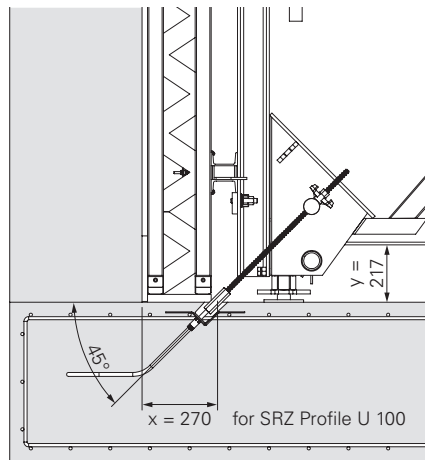

Fig. A3.07b

Girder circular formwork

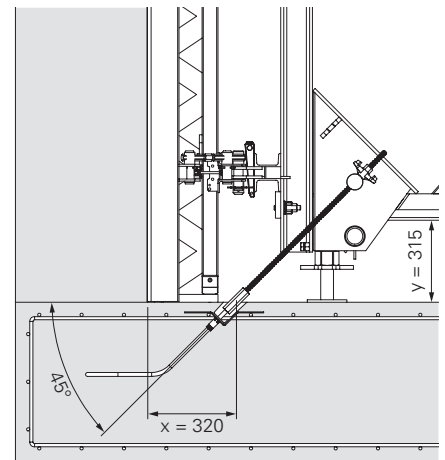

Fig. A3.07c

Standard configurations for civil engineering

Brace Frame SB VARIOKIT / SCS (Fig. A3.08a – Fig. A3.08c)



The specified dimension x must be determined on a project-specific basis for anchoring in the interference-free area.
The value changes depending on the formwork selected.

SB VARIOKIT

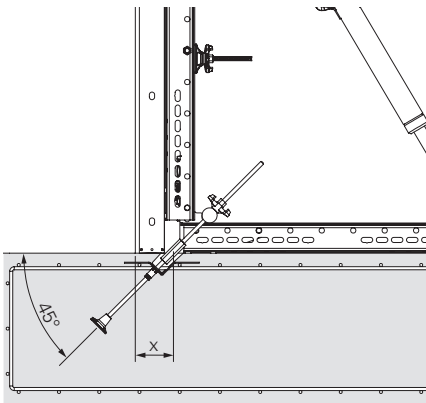

Fig. A3.08a

SB SCS with anchor tie yoke

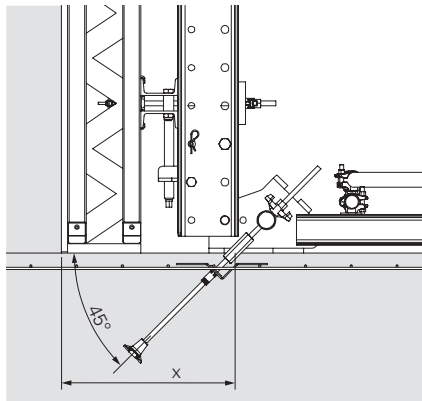

Fig. A3.08b

SB SCS with Steel Waler SRU

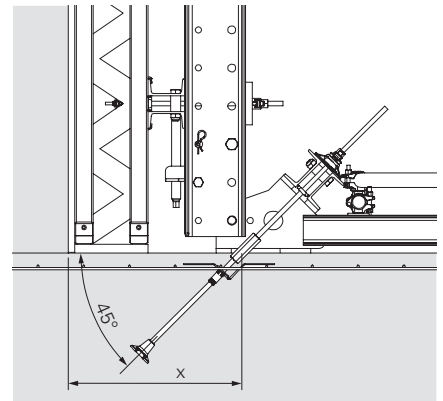

Fig. A3.08c

Standard configuration for rock anchor



Observe the instructions for use for Rock Anchor DW HB 15.



Project-specific planning required,
 $y \leq 315$ mm.
All dimensions given in mm.

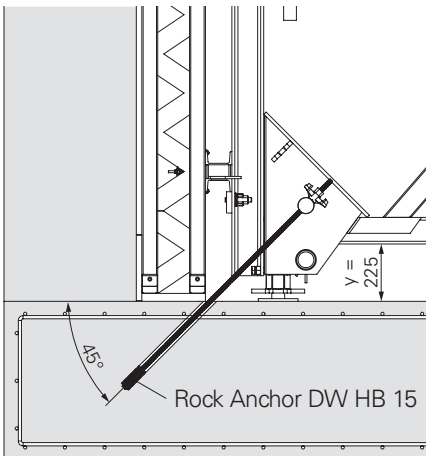

Fig. A3.09

Tie installation with V-Tie Holder for DW 15, 20, 26

With the V-tie holder and leading tie coupler, accurate assembly of the tension tie under 45° is possible.



Seal leading tie couplers with suitable means.



Verification of the safe transfer of the bearing reactions into the building and subsequently into the ground is the responsibility of the contractor – determining the anchoring depth.

Tools required

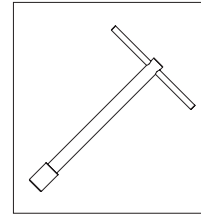

Tens. Rod Spanner DW20/26 ga

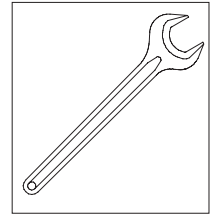

Spanner AF 30, 36, 46, 70

Work sequence for lost tie rod

Installation in reinforcement

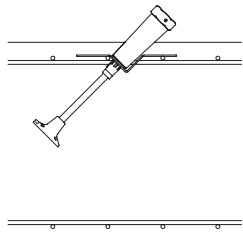

Installation of the V-tie holder and leading tie coupler, for example with tie wire. Concreting.

After concreting

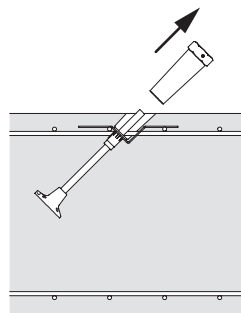

Removal of leading tie coupler with spanner AF 70. Check tie rod to ensure it is firmly in place.

Connection to SB

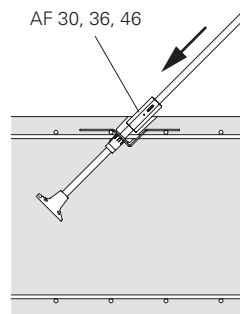

Untighten the hex. nut and tie rod using the spanner.

Dismantling SB

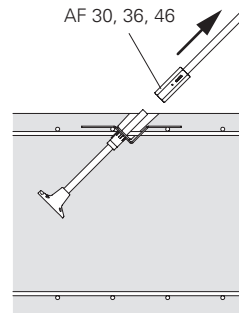

Unscrew the tie rod and hex. nut using the spanner. Fill hole.

Work sequence for re-usable tie rods

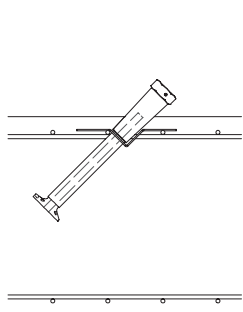

Installation of the V-tie holder and leading tie coupler. Fix in place, for example with tie wire. Concreting.

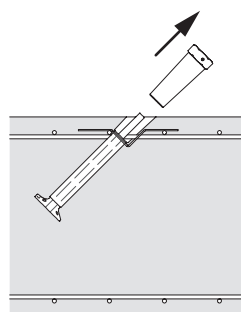

Removal of leading tie coupler with spanner AF 70. Check tie rod to ensure it is firmly in place.

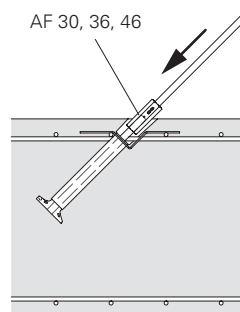

Untighten the hex. nut and tie rod using the spanner.

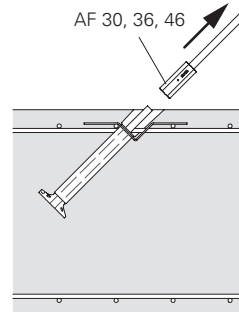

Unscrew the tie rod and hex. nut using the spanner.

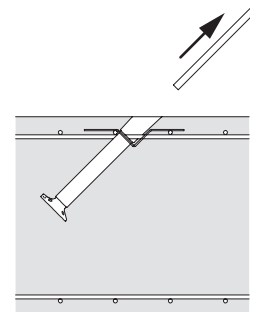

Unscrew the tie rod with the tension rod spanner. Fill hole.

Tie System DW 15 Version with tie rod

Reusable tie parts:

- 9 Tie Rod DW15
- 28 Leading Anchor Coupler DW15

Lost tie parts:

- 5 V-Tie Holder DW15
- 12 Threaded Anchor Plate DW15
- 29 Tube Ø32 mm rough

(Fig. A3.10a)

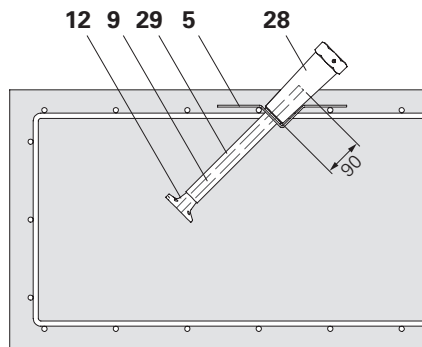

Fig. A3.10a

Tie System DW 15 Version with anchorage loop

Reusable tie parts:

- 28 Leading Anchor Coupler DW15

Lost tie parts:

- 5 V-Tie Holder DW15
- 11 Anchorage Loop DW15

(Fig. A3.10b)

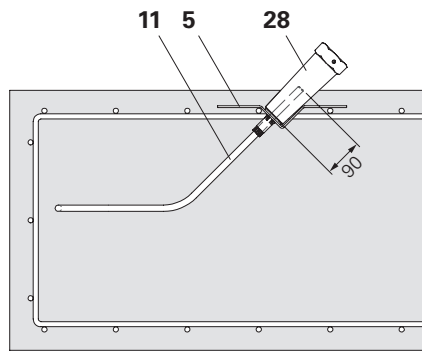

Fig. A3.10b

Tie System DW 20

Reusable tie parts:

- 20 Tie Rod DW20
- 30 Leading Anchor Coupler DW20

Lost tie parts:

- 22 Threaded Anchor Plate DW20
- 31 V-Tie Holder DW20
- 32 Tube Ø42 mm rough

(Fig. A3.10c)

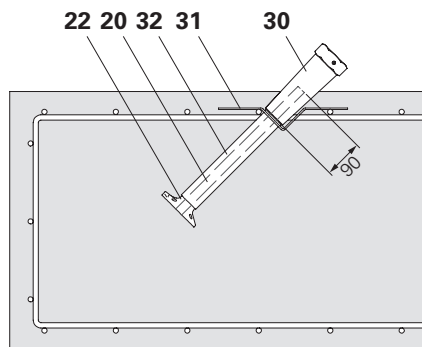

Fig. A3.10c

Tie System DW 26

Reusable tie parts:

- 25 Tie Rod DW26
- 33 Leading Anchor Coupler DW26

Lost tie parts:

- 27 Threaded Anchor Plate DW26
- 32 Tube Ø42 mm rough
- 34 V-Tie Holder DW26

(Fig. A3.10d)

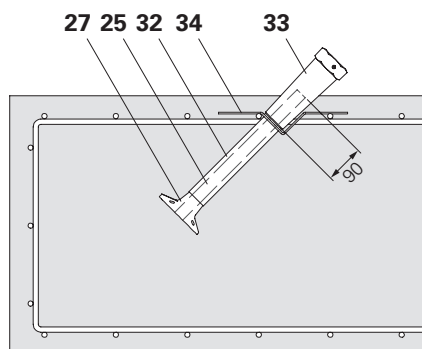

Fig. A3.10d

Assembling SB-A0, A, B, C

Height combinations (examples)

(Fig. B1.01)

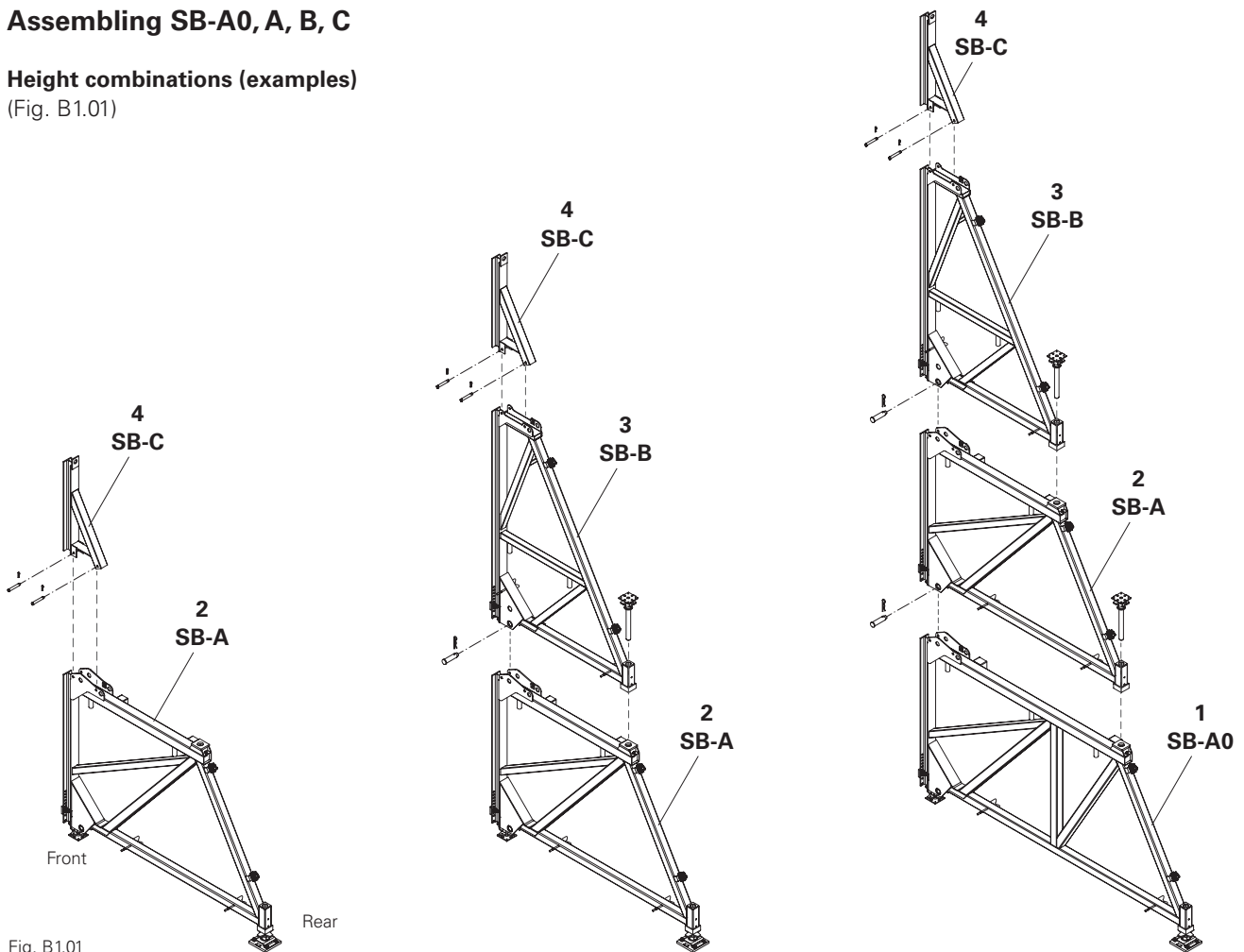

Fig. B1.01



Assemble brace frames on clean, level and sufficiently load-bearing surfaces!

Assembly

Assembly is to take place horizontally and with the crane.

1. Place all required individual brace frames (SB-A0, A, B, C) on squared timber in sequence.

(Fig. B1.02)

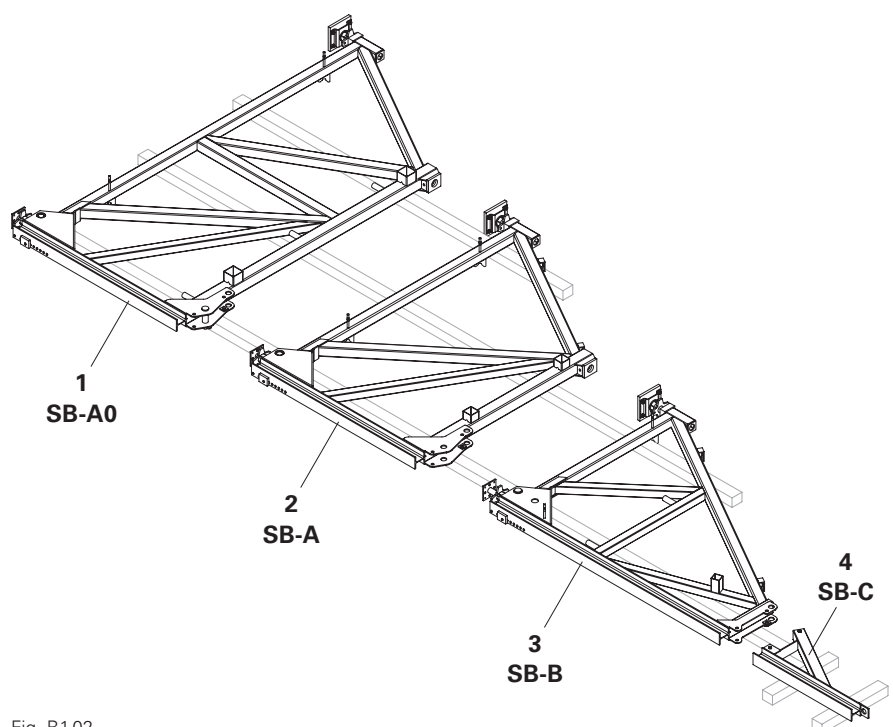

Fig. B1.02

Connecting SB-A0 to SB-A

- Remove the spindles from Brace Frame SB-A (2).
Front: Spindle Base SB (2.2) and Adjusting Nut SB (2.3).
Rear: Waler Jack TR 60 x 9/43 (2.4).
- Push the brace frames (1 + 2) together.
- Connect the brace frames (1 + 2) at the front with bolts $\text{\O}50 \times 150$ mm (1.5) and cotter pin 8 (1.6).
- Connect the brace frame at the rear with Spindle Base SB (2.2) and Adjusting Nut SB (2.3).
(Fig. B1.03a + Fig. B1.03b)

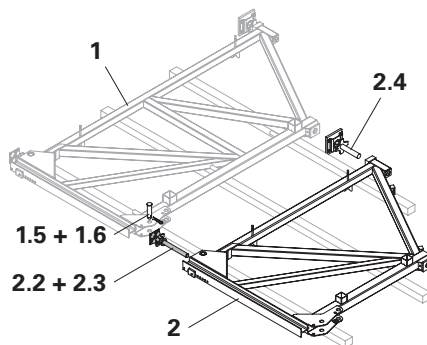

Fig. B1.03a

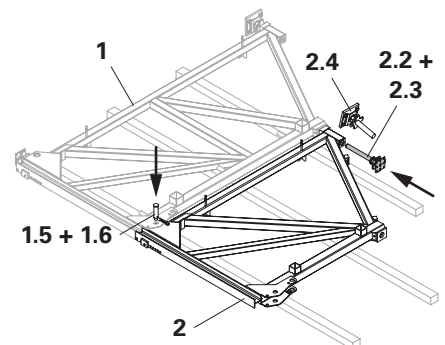

Fig. B1.03b

Connecting SB-A to SB-B

- Remove the spindles from the brace frame. Front: Spindle Base SB (3.2) and Adjusting Nut SB (3.3).
Rear: Waler Jack TR 60 x 9/43 (3.4).
(Fig. B1.04a)
- Push the brace frames (2 + 3) together.
- Connect the brace frames (2 + 3) at the front with bolts $\text{\O}50 \times 150$ (3.5) and cotter pin 8 (3.6).
- Connect the brace frame at the rear with Spindle Base SB (3.2) and Adjusting Nut SB (3.3).
(Fig. B1.04b)

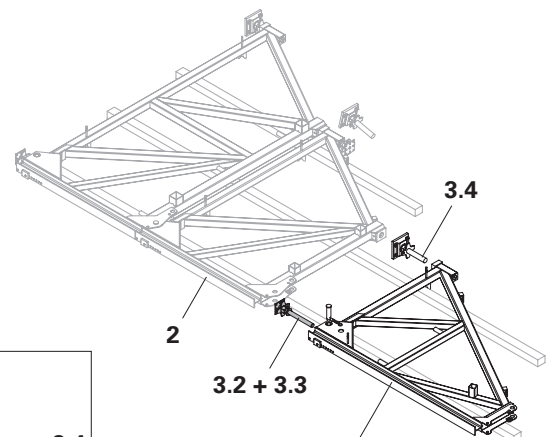

Fig. B1.04a

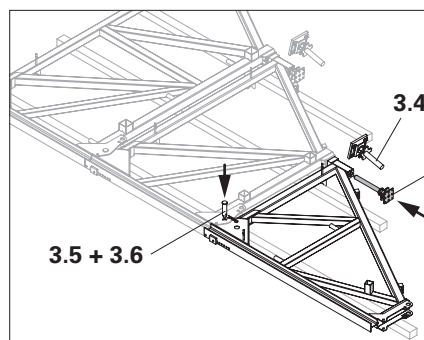

Fig. B1.04b

Connecting to SB-C

Example involving SB-B

- Remove bolt $\text{\O}25 \times 180$ with clamping sleeve $\text{\O}6$ (4.1) and Cotter Pin 4/1 ga (4.2) from Brace Frame SB-C (4).
- Push the brace frames (3 + 4) together and connect them with bolt $\text{\O}25 \times 180$ mm, clamping sleeve $\text{\O}6$ (4.1) and Cotter Pin 4/1 ga (4.2).
(Fig. B1.05a)

Load transfer

Adjust the formwork support (1.7) to suit the formwork used in accordance with the project plan.
(Fig. B1.05b)

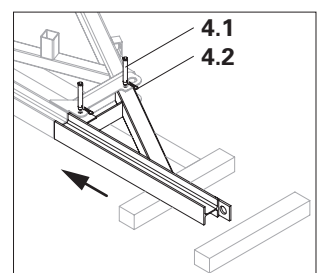

Fig. B1.05a

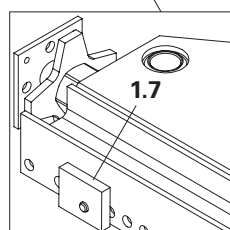

Fig. B1.05b

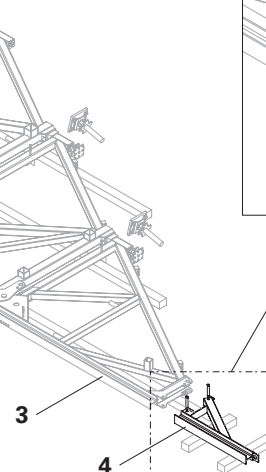

Fig. B1.05

General information



Danger

Incorrect anchoring results in the static system of the formwork unit being changed which could lead to large deformations; even breakage in extreme cases!

This could result in serious injuries or even death.

- ⇒ The support (connection) for the elements must always be established at the point where the tie rod is installed for normal use (double-sided).
- ⇒ Check the structural integrity of the formwork unit.
- ⇒ When extending the formwork, take into account the information provided by PERI for the respective system.
- ⇒ After each concreting or relocation operation, check the fasteners / wedges and ensure that they are permanently secured, if necessary.

Girder Formwork VARIO GT 24, RUNDFLEX and RUNDFLEX Plus-2



- Assembly is to take place horizontally and with the crane.
- Place the formwork unit on a clean, level and sufficiently load-bearing surface. Place squared timbers underneath.
- Depending on where the top edge of the brace frame lies, it may only be possible to construct the concreting platform using individual brackets, guardrail posts and decking and guardrail boards provided by the contractor.
- Take into account permissible influence widths; see PERI Design Information for Brace Frame SB. If no influence widths are available, these must be determined on a project-specific basis.

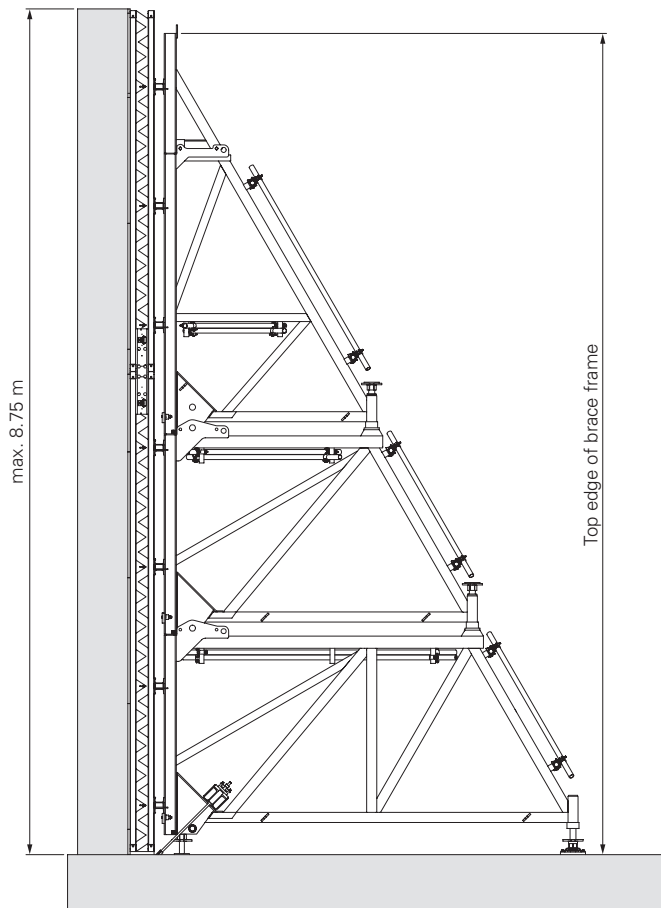

Fig. B2.01

Combination table

Standard configuration with VARIO GT 24 Girder Wall Formwork										
Formwork height	Girder 1	Girder 2	Girder 3 (Overlap girders)	Tie position 1	Tie position 2	Tie position 3	Tie position 4	Tie position 5	Tie position 6	Tie position 7
240	240			49.0	118.4					
240	240			49.0	118.4					
270	270			49.0	148.0					
270	270			49.0	148.0					
270	270			49.0	177.6					
300	300			49.0	148.0					
300	300			49.0	177.6					
300	300			49.0	177.6					
330	330			49.0	118.4	118.4				
330	330			49.0	118.4	118.4				
360	360			49.0	118.4	118.4				
360	360			49.0	118.4	118.4				
390	390			49.0	118.4	118.4				
390	390			49.0	118.4	148.0				
390	390			49.0	118.4	148.0				
390	390			49.0	118.4	148.0				
420	420			49.0	118.4	118.4	118.4			
420	420			49.0	118.4	118.4	118.4			
450	450			49.0	118.4	118.4	118.4			
450	450			49.0	118.4	118.4	118.4			
480	480			49.0	118.4	118.4	118.4			
480	480			49.0	118.4	118.4	118.4			
510	510			49.0	118.4	118.4	148.0			
540	540			49.0	118.4	148.0	148.0			
540	540			49.0	118.4	118.4	118.4	118.4		
570	570			49.0	118.4	118.4	118.4	118.4		
600	600			49.0	118.4	118.4	118.4	118.4		
630	240	390		49.0	118.4	121.8	118.4	148.0		
660	240	420		49.0	118.4	121.8	148.0	148.0		
690	240	450		49.0	118.4	121.8	118.4	118.4	118.4	
720	240	480		49.0	118.4	121.8	118.4	118.4	118.4	
750	240	510		49.0	118.4	121.8	118.4	118.4	148.0	
780	240	540		49.0	118.4	121.8	118.4	118.4	118.4	118.4
810	480	330	540	49.0	118.4	118.4	118.4	118.4	118.4	118.4
840	600	240	450	49.0	118.4	118.4	118.4	118.4	118.4	118.4
870	600	270	480	49.0	118.4	118.4	118.4	118.4	118.4	148.0

All dimensions in cm.

Tab. B2.01

B2 Connecting to systems SB-A0, A, B, C



Refer to the Instructions for Assembly and Use for the formwork system used.

	SB-A0	SB-A	SB-B	SB-C	Standard configuration
		X			SB A
			X		SB B
		X			SB A
			X		SB B
		X		X	SB A + C
		X			SB A
			X		SB B
		X		X	SB A + C
			X		SB B
		X		X	SB A + C
			X		SB B
		X		X	SB A + C
			X	X	SB B + C
		X	X		SB A + B
			X	X	SB B + C
		X	X		SB A + B
			X	X	SB B + C
		X	X		SB A + B
			X	X	SB B + C
		X	X		SB A + B
		X	X		SB A + B
		X	X		SB A + B
		X	X	X	SB A + B + C
		X	X	X	SB A + B + C
		X	X	X	SB A + B + C
		X	X	X	SB A+B+C
		X	X	X	SB A+B+C
	X	X	X	(X)	SB A0 + A + B + (C)
	X	X	X	(X)	SB A0 + A + B + (C)
	X	X	X	(X)	SB A0 + A + B + (C)
	X	X	X	X	SB A0 + A + B + C
	X	X	X	X	SB A0 + A + B + C
	X	X	X	X	SB A0 + A + B + C
	X	X	X	X	SB A0 + A + B + C

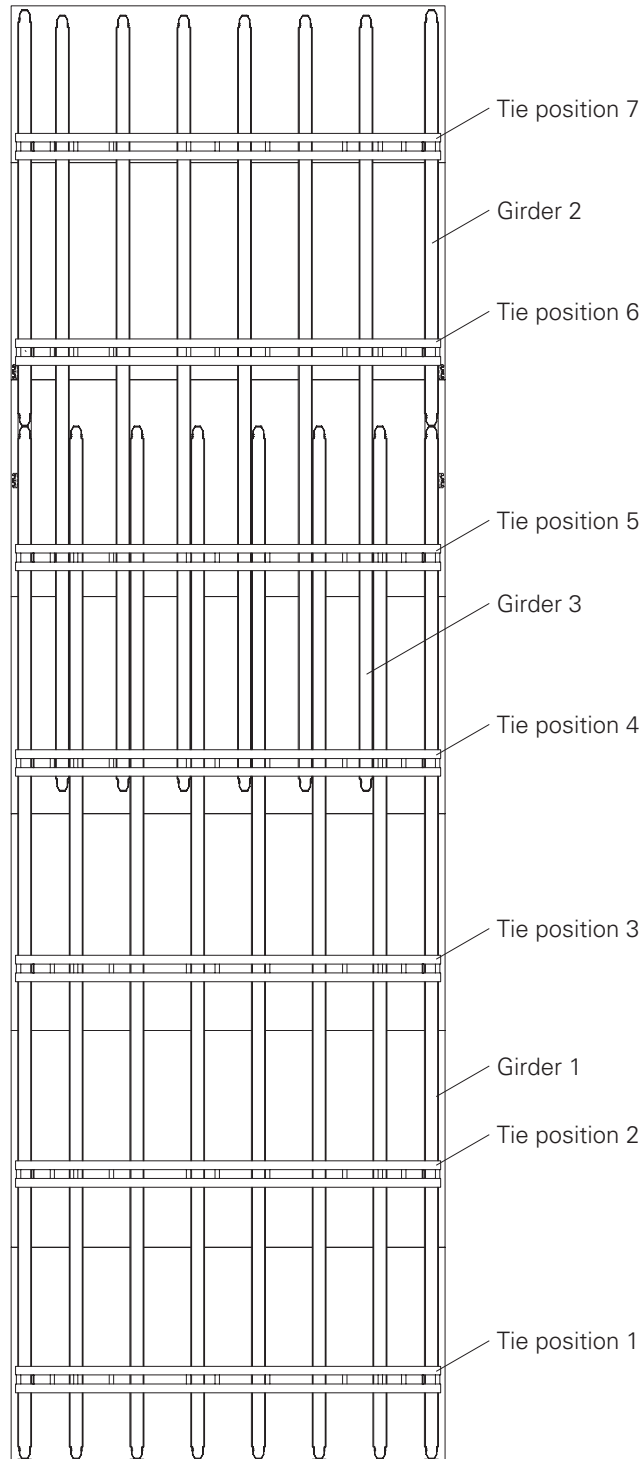

Installation on horizontal VARIO GT 24.

Max. concreting height $h = 8.75$ m.
Refer to the Instructions for Assembly and Use for the system.

Required components per ledger section:

35 Waler Connector SB-A0, A, B, C	1x
36 Wedge K ga	1x
Alternatively	
38 Hook Strap SB-2 ga	1x



Leave the brace frame attached to the crane until it is mounted.

Connecting with Waler Connector SB-A, B, C

1. Prepare the installation site, for example with squared timbers.
 2. Set the formwork down at the installation site.
 3. Swing the brace frame into position with the crane.
 4. Slide the required number of waler connectors SB-A0, A, B, C (**35**) onto the profile of the brace frame - number depends on the length of the waler.
 5. Adjust the formwork support (**1.7**) to the required height (stop).
 6. Lower the brace frame, and push the waler connectors through the steel walers. The bottom steel waler lies against the formwork support.
 7. Fix Waler Connectors SB-A0, A, B, C (**35**) in place with Wedge K ga (**36**) starting from the bottom.
- (Fig. B2.02 – Fig. B2.02b)
8. Fit the second brace frame.
 9. Brace the brace frames with scaffolding tubes (horizontal and vertical) See Section "B3 Bracing SB-A0, A, B, C" on page 49.
- (Fig. B2.03)
9. Check all fixing points to ensure they are secure.
 10. Remove crane lifting gear.
 11. Adjust the height of the movable unit with the spindles.

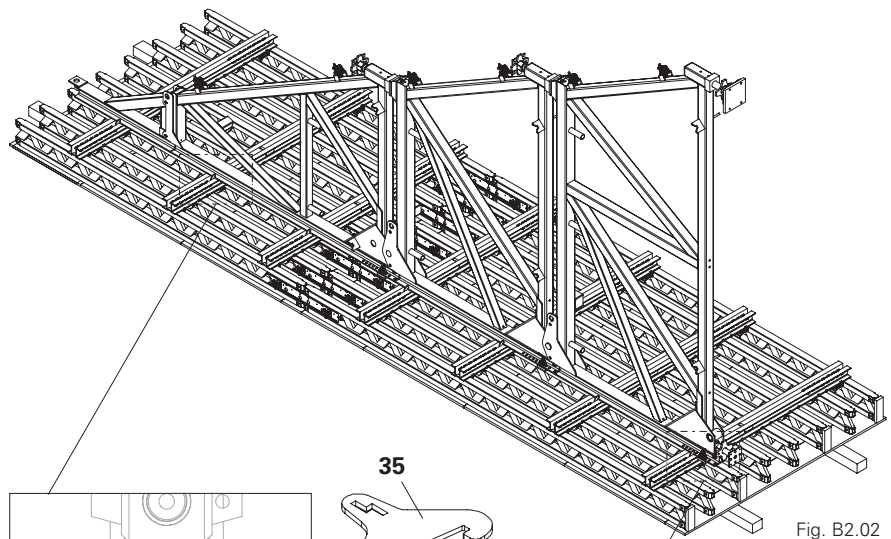

Fig. B2.02

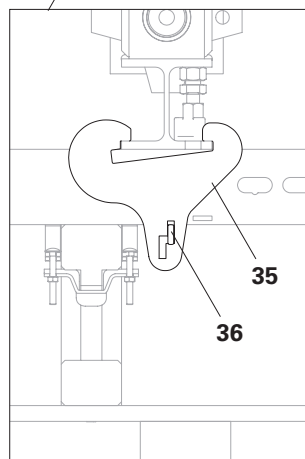

Fig. B2.02a

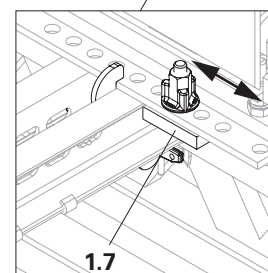
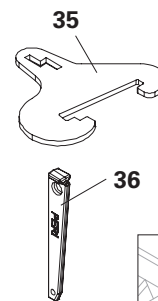

Fig. B2.02b

Erection

Erect, move, align and anchor the moveable unit with the crane by the load-bearing points. See Section "B4 Moving" on page 50.

Alternatively

Hook Strap SB-2 ga (38) See Section "C1 Connecting to system SB-2" on page 52.

Place a board underneath to prevent slipping. (Fig. B2.04)

Platforms

Do not mount concreting platforms until after erection.

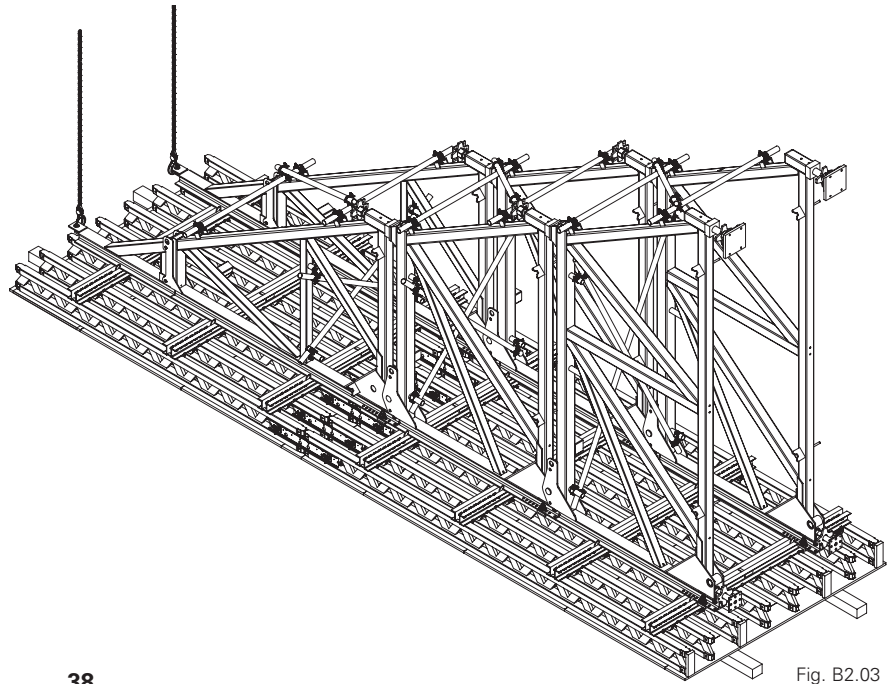

Fig. B2.03

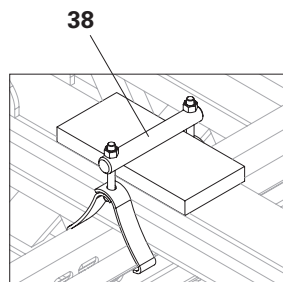

Fig. B2.04

Installation on horizontal RUNDFLEX.
Max. concreting height $h = 8.40$ m.
Refer to the Instructions for Assembly and Use for the system.

Required components per ledger section:

35 Waler Connector SB-A0,A,B,C	1x
36 Wedge K ga	1x



- When planning, make sure that the ends of the brace frames do not touch (high elements, inner radius min. 6.0 m).
- The elements are adjusted to suit the radius.
- Leave the brace frame attached to the crane until it is mounted.

Connecting with Waler Connector SB-A, B, C

1. Prepare the installation site, for example with squared timbers.
 2. Set the formwork down at the installation site.
 3. Swing the brace frame into position with the crane.
 4. Slide the required number of Waler Connectors SB-A0,A,B,C (**35**) onto the profile of the brace frame - number depends on the length of the waler.
 5. Adjust the formwork support (**1.7**) to the required height (stop).
 6. Lower the brace frame and push the Waler Connectors SB-A0,A,B,C (**35**) through the distribution walers (**39**). The bottom distribution waler (**39**) lies against the formwork support.
 7. Fix Waler Connectors SB-A0,A,B,C (**35**) in place with Wedge K ga (**36**) starting from the bottom.
- (Fig. B2.05 – Fig. B2.05b)
8. For further work steps, see Section "B2 Connecting to systems SB-A0, A, B, C" on page 31 from action step 6.

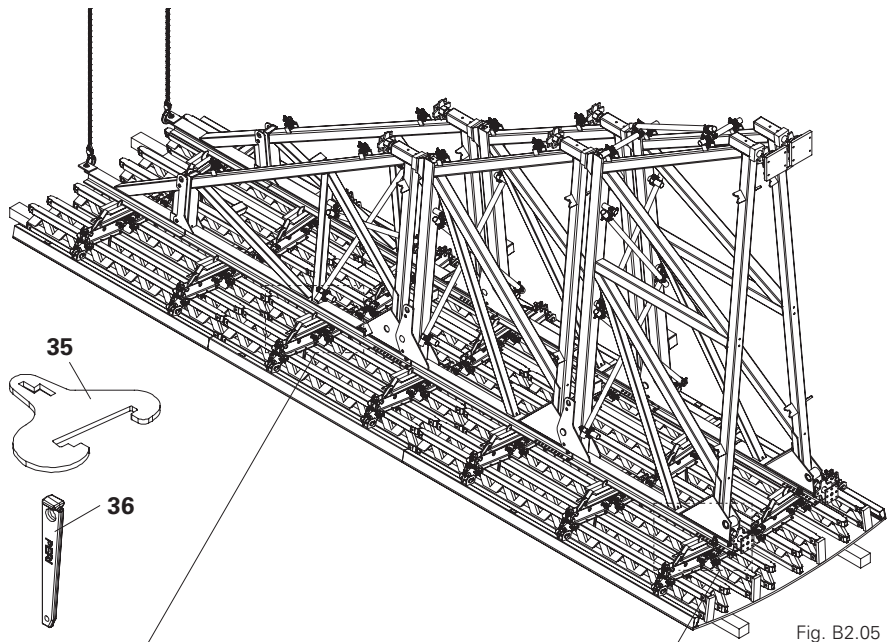

Fig. B2.05

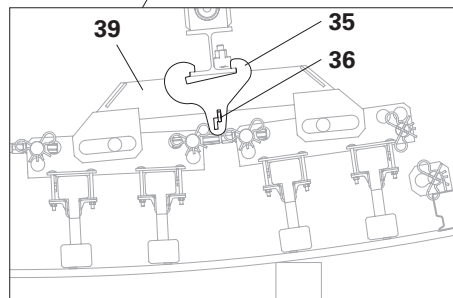

Fig. B2.05a

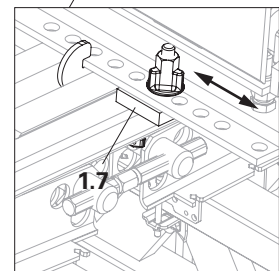

Fig. B2.05b

Assembly on vertical element VARIO GT 24 and RUNDFLEX

1. Erect, move and align the formwork unit and temporarily secure with push-pull props. (not shown)
2. With the crane, lift the brace frame in behind the steel walers/distribution walers. Use a guide rope.

(Fig. B2.06a)

3. Slide Waler Connectors SB-A0,A,B,C (35) onto the profiles of the brace frames, insert into the steel walers/distribution walers, and secure with Wedge K ga (36).

(Fig. B2.05a + Fig. B2.06b)

The steel waler/distribution waler lies against the formwork support (1.7).

(Fig. B2.06b)

4. For further work steps, see Section "B2 Connecting to systems SB-A0, A, B, C" on page 31 from action step 6.

Example: VARIO, lifting in the brace frame

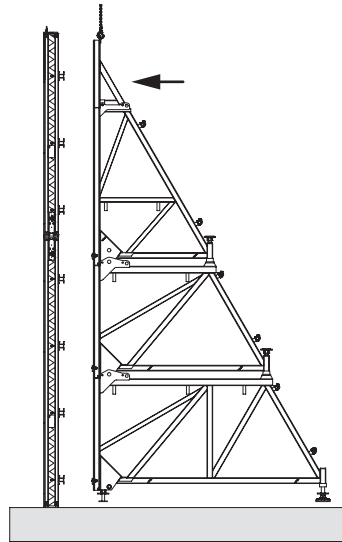

Fig. B2.06a

Example: RUNDFLEX mounted

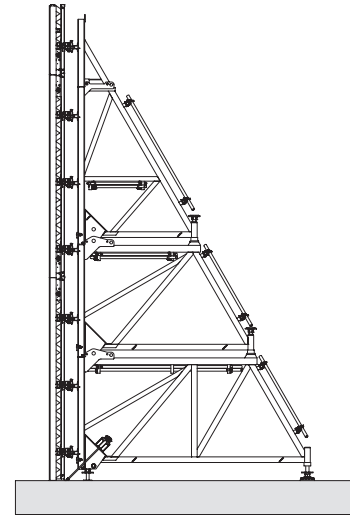

Fig. B2.06b

Installation on horizontal RUNDFLEX Plus-2.

Max. concreting height $h = 8.40$ m.
Refer to the Instructions for Assembly and Use for the system.

Required components per ledger section:

40 Connector SB/RFP 1x



- When planning, make sure that the ends of the brace frames do not touch (high elements, inner radius min. 6.0 m).
- The elements are adjusted to suit the radius.
- Leave the brace frame attached to the crane until it is mounted.

Connection with Brace Frame Connector RFP

1. Fix the Brace Frame Connectors SB/RFP (40) to the brace connectors of the outer trapezoidal profiles, AF 24.
2. Adjust the formwork support (1.7) to the required height (stop).
3. Lift the brace frame into the open Brace Frame Connectors SB/RFP (40) with the crane.
4. Close the Brace Frame Connectors SB/RFP (40) and hammer the wedges into place. (Fig. B2.07 – Fig. B2.07b)
5. For further work steps, see Section "B2 Connecting to systems SB-A0, A, B, C" on page 31 from action step 6.

Assembly on vertical element Preparing the element:

1. Fix the Brace Frame Connectors SB/RFP (40) to the brace connectors of the outer trapezoidal profiles, AF 24.
2. Mount the concreting platform: see Instructions for Assembly and Use of the formwork system.
3. Fix temporary push-pull prop and kicker to the central trapezoidal profile.
4. Erect unit, move to place of use, align and anchor.

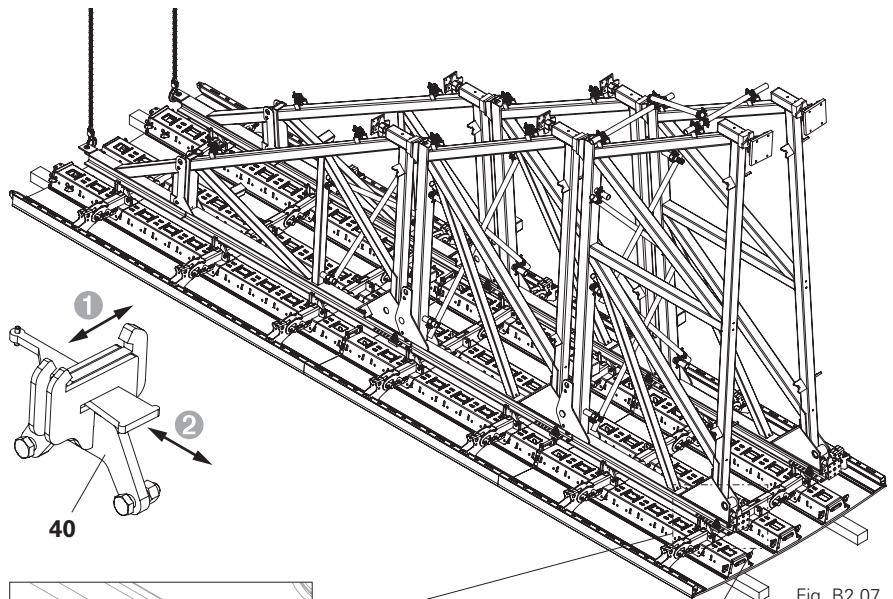

Fig. B2.07

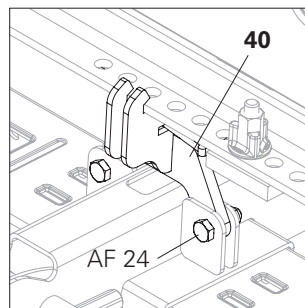

Fig. B2.07a

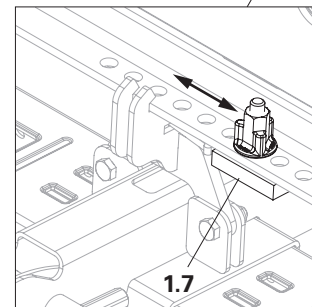

Fig. B2.07b

Assembly of brace frame:

5. Lift the brace frames into the open Brace Frame Connectors SB/RFP (40) with the crane. Secure the wedges. Formwork support rests against these. (Fig. B2.08)
6. For further work steps, see Section "B2 Connecting to systems SB-A0, A, B, C" on page 31 from action step 6.
7. Remove temporary push-pull prop and kicker.

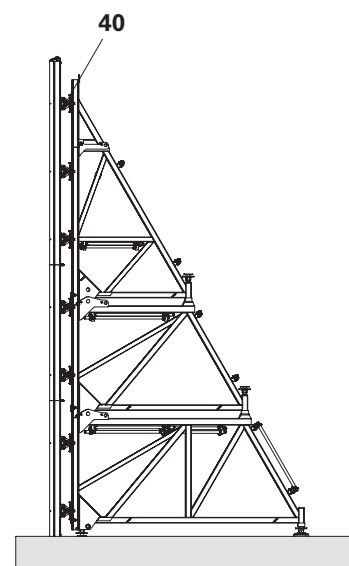

Fig. B2.08

Panel formwork MAXIMO, TRIO, DOMINO



- Assembly is to take place horizontally and with the crane.
- Place the formwork unit on a clean, level and sufficiently load-bearing surface. Place squared timbers underneath.
- Depending on where the top edge of the brace frame lies, it may only be possible to construct the concreting platform using individual brackets, guardrail posts and decking and guardrail boards provided by the contractor.
- Take into account permissible influence widths; see PERI Design Information for Brace Frame SB.
- Mount platforms at a later stage.
- Definitions:
 - vertical: vertical tie profile
 - horizontal: horizontal tie profile
- Leave the brace frame attached to the crane until it is mounted.

Max. concreting height:

Vertical elements h = 8.70 m

(Fig. B2.09)

Horizontal elements h = 8.10 m

Refer to the Instructions for Assembly and Use for the system.

Required components per tie point: MAXIMO

41 Connection SB-A0,A,B,C/ MX,TR,D	1x
42 Pin SB/MX ga	1x
43 Sleeve SB/MX ga	1x
44 Sleeve SB/MX WDMX*	1x

*with removable sealing

Required components per tie point: TRIO, DOMINO

41 Connection SB-A0,A,B,C/ MX,TR,D	1x
45 Pin SB/TR,D ga	1x

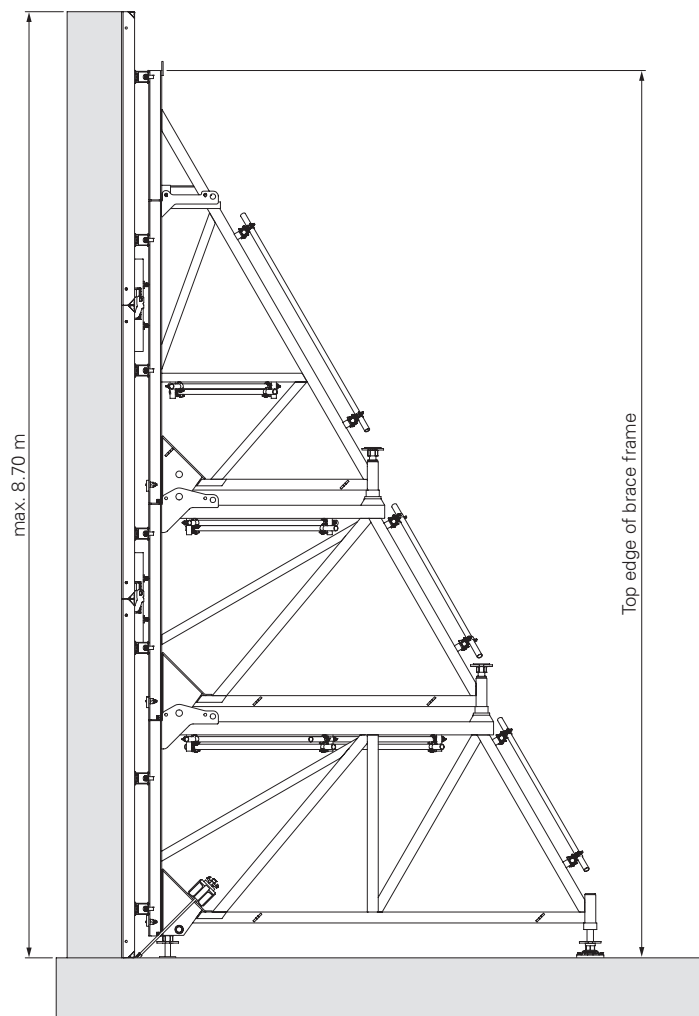
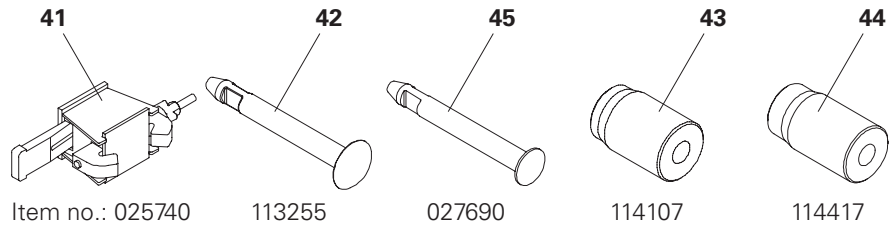

Fig. B2.09

Assembly

Connecting Connector SB-A0,A,B,C/ TR,MX,D to element

Preparation

1. Position the elements or element unit on trestles.
2. Insert Sleeves SB/MX (43 / 44) into the tie holes; for MAXIMO only.
3. Insert Bolt SB (42 / 45) from below.
4. Place Connector SB-A0,A,B,C/
MX,TR,D (41) on the tie hole and fix in place with wedge.
5. Fit additional Connectors SB-A0,A,B,C/
MX,TR,D (41) to the tie holes.

(Fig. B2.10)

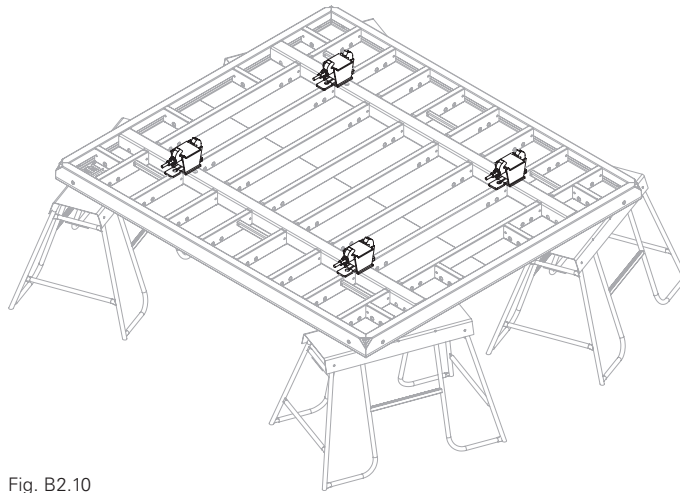
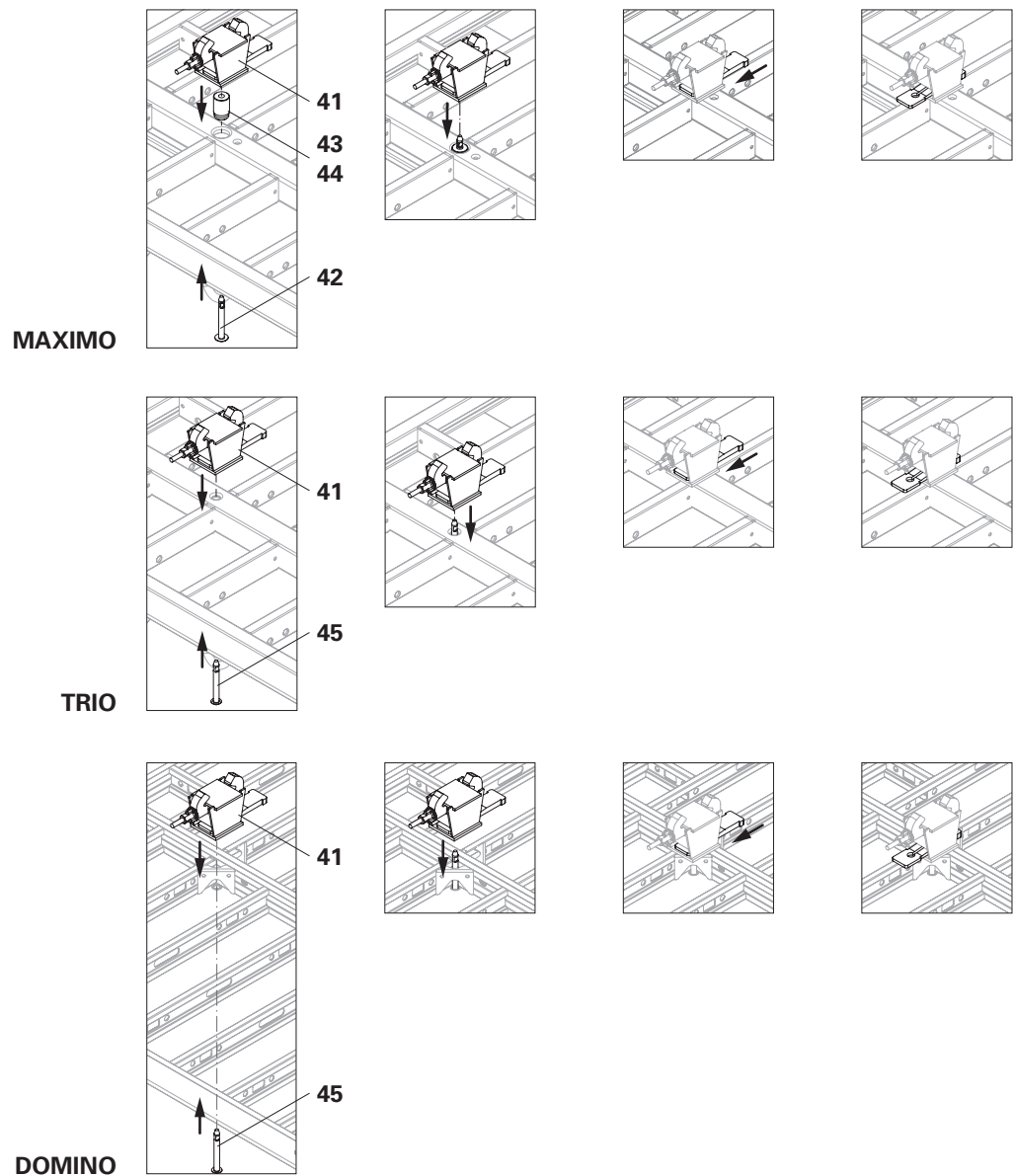

Fig. B2.10





Leave the brace frame attached to the crane until it is mounted.

Mounting the brace frame

1. Position the elements or element unit on squared timber.
2. Adjust the formwork support (1.7) to the required height (stop).
3. Open the hook on the right (41.1).
4. Lift the brace frame into the open Connectors SB-A0,A,B,C/MX,TR,D (41) with the crane.

The bottom Connector SB lies against the formwork support.

4. Close the hook on the right (41.1) with the cam nut, starting from the bottom.

(Fig. B2.11 – Fig. B2.12)

For further work steps, see Section B2 VARIO GT 24 from Point 6.

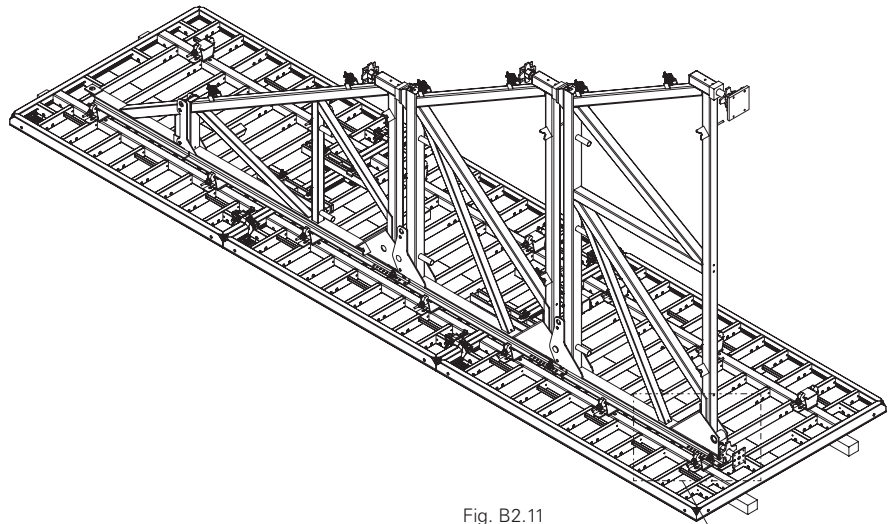

Fig. B2.11

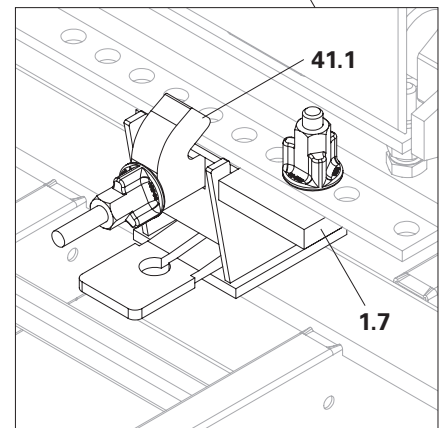

Fig. B2.11a

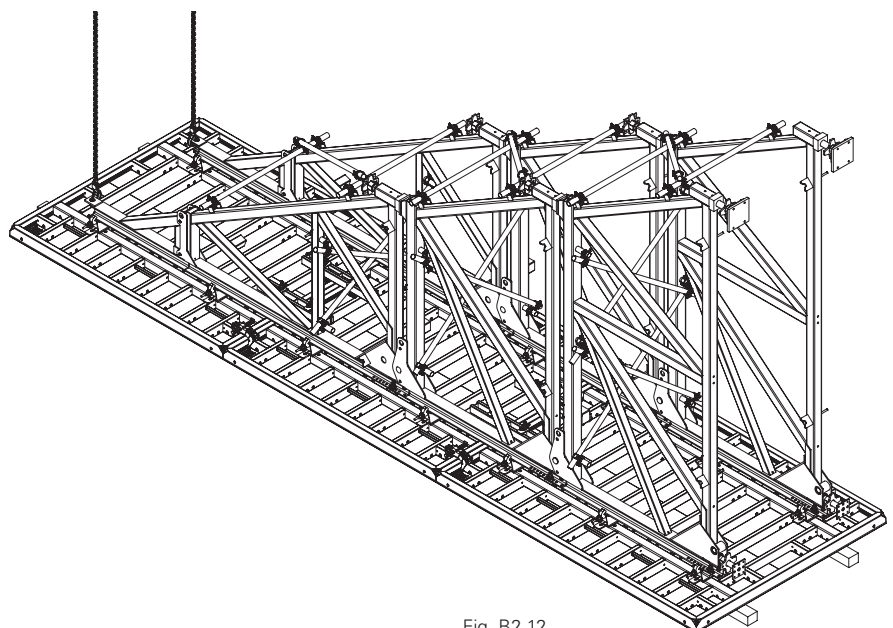
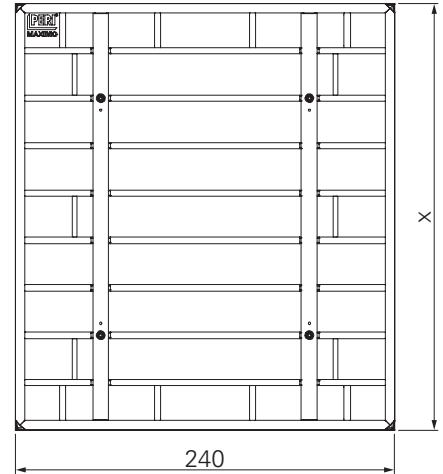

Fig. B2.12

MAXIMO combination table

Standard configuration with MAXIMO Panel Formwork (vertical), W = 240									
Formwork height	Element 1	Element 2	Element 3	Element 4	SB-A0	SB-A	SB-B	SB-C	Standard configuration
240	120	120				X			SB A
270	270						X		SB B
300	270	30					X		SB B
330	270	60				X		X	SB A + C
330	330						X		SB B
360	270	90				X		X	SB A + C
360	330	30					X	X	SB B + C
390	270	120				X		X	SB A + C
390	330	60					X	X	SB B + C
420	270	120	30				X	X	SB B + C
420	330	90					X	X	SB B + C
450	270	120	60			X		X	SB A + B
450	330	120					X		SB B + C
480	270	120	90			X	X		SB A + B
480	330	120	30			X	X		SB A + B
510	270	120	120			X	X		SB A + B
510	330	120	60			X	X		SB A + B
540	270	270				X	X		SB A + B
540	330	120	90			X	X	X	SB A + B + C
570	270	270	30			X	X	X	SB A + B + C
570	330	120	120			X	X	X	SB A + B + C
600	270	270	60			X	X	X	SB A + B + C
600	330	120	120	30		X	X	X	SB A + B + C
600	330	270				X	X	X	SB A + B + C
630	270	270	90			X	X	X	SB A + B + C
630	330	120	120	60		X	X	X	SB A + B + C
630	330	270	30		X	X	X		SB A0 + A + B
660	270	270	120			X	X	X	SB A + B + C
660	330	330			X	X	X		SB A0 + A + B
690	270	270	120	30	X	X	X		SB A0 + A + B
690	330	270	90		X	X	X		SB A0 + A + B
690	330	330	30		X	X	X		SB A0 + A + B
720	270	270	120	60	X	X	X		SB A0 + A + B
720	330	270	120		X	X	X		SB A0 + A + B
720	330	330	60		X	X	X		SB A0 + A + B
750	270	270	120	90	X	X	X	X	SB A0 + A + B + C
750	330	330	90		X	X	X	X	SB A0 + A + B + C
780	270	270	120	120	X	X	X	X	SB A0 + A + B + C
780	330	330	120		X	X	X	X	SB A0 + A + B + C
810	270	270	270		X	X	X	X	SB A0 + A + B + C
810	330	330	120	30	X	X	X	X	SB A0 + A + B + C
840	330	330	120	60	X	X	X	X	SB A0 + A + B + C
840	330	270	120	120	X	X	X	X	SB A0 + A + B + C
870	330	270	270		X	X	X	X	SB A0 + A + B + C



Elements

Element MX 330 x 240	114426
Element MX 270 x 240	112006
Element MX 120 x 240	112104
Element MX 90 x 240	112115
Element MX 60 x 240	112126
Element MX 30 x 240	112133

All dimensions in cm.

Tab. B2.02

Standard configuration with MAXIMO Panel Formwork (horizontal), W = 270									
Formwork height	Element 1	Element 2	Element 3	Element 4	SB-A0	SB-A	SB-B	SB-C	Standard configuration
240	240					X			SB A
270	240	30					X		SB B
300	240	60					X		SB B
330	240	90					X		SB B
330	330						X		SB B
360	240	120				X		X	SB A + C
360	330	30					X	X	SB B + C
390	240	120	30				X	X	SB B + C
390	330	60					X	X	SB B + C
420	240	120	60				X	X	SB B + C
420	330	90					X	X	SB B + C
450	240	120	90				X	X	SB B + C
450	330	120					X	X	SB B + C
480	240	240				X	X		SB A + B
480	330	120	30			X	X		SB A + B
510	240	240	30			X	X	X	SB A + B + C
510	330	120	60			X	X		SB A + B
540	240	240	60			X	X	X	SB A + B + C
540	330	120	90			X	X	X	SB A + B + C
570	240	240	90			X	X	X	SB A + B + C
570	330	240				X	X	X	SB A + B + C
600	240	240	120			X	X	X	SB A + B + C
600	330	240	30			X	X	X	SB A + B + C
630	240	240	120	30	X	X	X		SB A0 + A + B
630	330	240	60		X	X	X		SB A0 + A + B
660	240	240	120	60	X	X	X		SB A0 + A + B
660	330	330			X	X	X		SB A0 + A + B
690	240	240	120	90	X	X	X		SB A0 + A + B
690	330	240	120		X	X	X		SB A0 + A + B
720	240	240	240		X	X	X		SB A0 + A + B
720	330	330	60		X	X	X		SB A0 + A + B
750	240	240	240	30	X	X	X	X	SB A0 + A + B + C
750	330	330	90		X	X	X	X	SB A0 + A + B + C
780	240	240	240	60	X	X	X	X	SB A0 + A + B + C
780	330	330	120		X	X	X	X	SB A0 + A + B + C
810	240	240	240	90	X	X	X	X	SB A0 + A + B + C
810	330	240	240		X	X	X	X	SB A0 + A + B + C
840	240	240	240	120	X	X	X	X	SB A0 + A + B + C
840	330	330	120	60	X	X	X	X	SB A0 + A + B + C

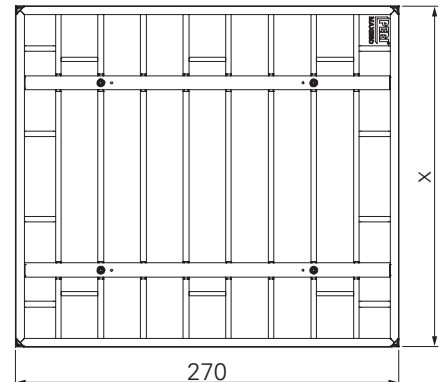

Elements

Element MX 330 x 270	116454
Element MX 270 x 240	112006
Element MX 270 x 120	112022
Element MX 270 x 90	112045
Element MX 270 x 60	112200
Element MX 270 x 30	112090

- All dimensions in cm.
- Elements MX 330 x 270 and Elements MX 18, 330 x 270 are set up vertically.

Tab. B2.03

B2 Connecting to systems SB-A0, A, B, C

Standard configuration with MAXIMO Panel Formwork (horizontal), W = 330									
Formwork height	Element 1	Element 2	Element 3	Element 4	SB-A0	SB-A	SB-B	SB-C	Standard configuration
240	240					X			SB A
270	240	30					X		SB B
270	270						X		SB B
300	240	60					X		SB B
300	270	30					X		SB B
330	240	90					X		SB B
330	270	60				X		X	SB A + C
360	240	120				X		X	SB A + C
360	270	90				X		X	SB A + C
390	240	120	30				X	X	SB B + C
390	270	120					X	X	SB B + C
420	240	120	60				X	X	SB B + C
420	270	120	30				X	X	SB B + C
450	240	120	90				X	X	SB B + C
450	270	120	60			X	X		SB A + B
480	240	240				X	X		SB A + B
480	270	120	90			X	X		SB A + B
510	240	240	30			X	X	X	SB A + B + C
510	270	240				X	X		SB A + B
540	240	240	60			X	X	X	SB A + B + C
540	270	270				X	X		SB A + B
570	240	240	90			X	X	X	SB A + B + C
570	270	270	30			X	X	X	SB A + B + C
600	240	240	120			X	X	X	SB A + B + C
600	270	270	60			X	X	X	SB A + B + C
630	240	240	120	30	X	X	X		SB A0 + A + B
630	270	270	90		X	X	X		SB A0 + A + B
660	240	240	120	60	X	X	X		SB A0 + A + B
660	270	270	120		X	X	X		SB A0 + A + B
690	240	240	120	90	X	X	X		SB A0 + A + B
690	270	270	120	30	X	X	X		SB A0 + A + B
720	240	240	240		X	X	X		SB A0 + A + B
720	270	270	120	60	X	X	X		SB A0 + A + B
750	240	240	240	30	X	X	X	X	SB A0 + A + B + C
750	270	240	240		X	X	X	X	SB A0 + A + B + C
780	240	240	240	60	X	X	X	X	SB A0 + A + B + C
780	270	270	240		X	X	X	X	SB A0 + A + B + C
810	240	240	240	90	X	X	X	X	SB A0 + A + B + C
810	270	270	270		X	X	X	X	SB A0 + A + B + C
840	240	240	240	120	X	X	X	X	SB A0 + A + B + C
840	270	270	240	60	X	X	X	X	SB A0 + A + B + C

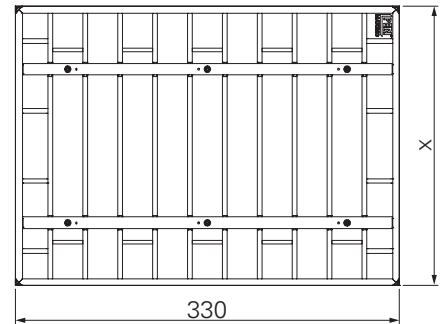

Elements

Element MX 330 x 270	116454
Element MX 330 x 240	114426
Element MX 330 x 120	114248
Element MX 330 x 90	114258
Element MX 330 x 60	114445
Element MX 330 x 30	114457

All dimensions in cm.

Tab. B2.04

TRIO combination table

Standard configuration with TRIO Panel Formwork (vertical), W = 240											
Formwork height	Element 1	Element 2	Element 3	Element 4	Element 5	SB-A0	SB-A	SB-B	SB-C	Standard configuration	
240	120	120						X		SB B	
270	270							X		SB B	
300	270	30						X		SB B	
330	330							X		SB B	
360	120	120	120					X	X	SB B + C	
360	330	30						X		SB B	
390	270	120						X	X	SB B + C	
420	270	120	30					X	X	SB B + C	
450	330	120						X	X	SB A + B	
480	330	120	30					X	X	SB A + B	
510	270	120	120					X	X	SB A + B	
540	270	270						X	X	SB A + B	
570	270	270	30					X	X	SB A + B	
570	330	120	120					X	X	X	SB A + B + C
600	330	120	120	30				X	X	X	SB A + B + C
600	330	270						X	X	X	SB A + B + C
630	330	270	30					X	X	X	SB A + B + C
660	270	270	120				X	X	X		SB A0 + A + B
660	330	330						X	X	X	SB A + B + C
690	270	270	120	30			X	X	X		SB A0 + A + B
690	330	330	30				X	X	X		SB A0 + A + B
720	330	120	120	120	30		X	X	X		SB A0 + A + B
720	330	270	120				X	X	X	X	SB A0 + A + B + C
750	270	120	120	120	120		X	X	X	X	SB A0 + A + B + C
750	330	270	120	30			X	X	X	X	SB A0 + A + B + C
780	270	270	120	120			X	X	X	X	SB A0 + A + B + C
780	330	330	120				X	X	X	X	SB A0 + A + B + C
810	270	270	270				X	X	X	X	SB A0 + A + B + C
810	330	330	120	30			X	X	X	X	SB A0 + A + B + C
840	270	270	270	30			X	X	X	X	SB A0 + A + B + C
870	330	270	270				X	X	X	X	SB A0 + A + B + C

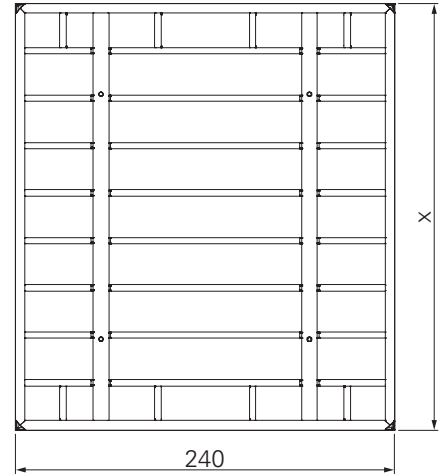

Elements

Element TR/4 330 x 240	054304
Element TR 270 x 240	022570
Element TR 120 x 240	022514
Element TR 30 x 120	022650

- All dimensions in cm.
- Vertical element H = 30 consists of 2x Elements TR 30 x 120.
- Only ever use Elements TR 30 x 120 as the top extension element!

Tab. B2.05

Standard configuration with TRIO Panel Formwork (horizontal), W = 270 / 330									
Formwork height	Element 1	Element 2	Element 3	Element 4	SB-A0	SB-A	SB-B	SB-C	Standard configuration
240	240					X			SB A
270	240	30					X		SB B
300	240	60				X		X	SB A + C
330	240	90				X		X	SB A + C
360	240	120					X	X	SB B + C
390	240	120	30				X	X	SB B + C
420	240	120	60			X	X		SB A + B
450	240	120	90			X	X		SB A + B
480	240	240				X	X		SB A + B
510	240	240	30			X	X		SB A + B
540	240	240	60			X	X	X	SB A + B + C
570	240	240	90			X	X	X	SB A + B + C
600	240	240	120			X	X	X	SB A + B + C
630	240	240	120	30		X	X	X	SB A + B + C
660	240	240	120	60	X	X	X		SB A0 + A + B
690	240	240	120	90	X	X	X		SB A0 + A + B
720	240	240	240		X	X	X		SB A0 + A + B
750	240	240	240	30	X	X	X	X	SB A0 + A + B + C
780	240	240	240	60	X	X	X	X	SB A0 + A + B + C
810	240	240	240	90	X	X	X	X	SB A0 + A + B + C

All dimensions in cm.

Tab. B2.06

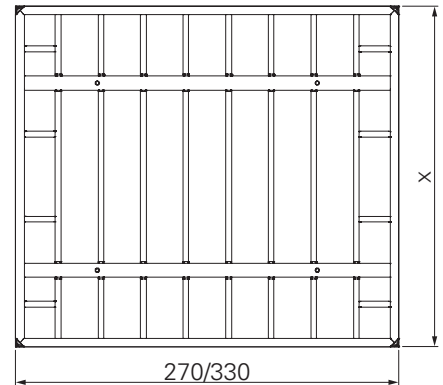

Elements 270

Element TR 270 x 240	022570
Element TR 270 x 120	022510
Element TR 270 x 90	022520
Element TR 270 x 60	022550
Element TR 270 x 30	022560

Elements 330

Element TR/4 330 x 240	054304
Element TR/4 330 x 120	054314
Element TR/4 330 x 90	054324
Element TR/4 330 x 60	054354
Element TR/4 330 x 30	054364

Diagonal bracing



- Diagonal bracing is required when moving and aligning the formwork unit with the crane.
 - Diagonal bracing is sometimes required, depending on the brace frame combination in use.
 - Values for the individual brace frame combinations depend on height, permissible influence width and fresh concrete pressure: see PERI Design Information for the Brace Frame SB.
 - The illustrations are examples only and show the diagonal bracing required when moving brace frames.
 - In the case of horizontal assembly, install diagonal bracing before the erection process begins.
- (Fig. B3.02)

Required components:

- 46** Scaffolding tube $\text{Ø}48.3 \times 3.2 \text{ mm}$
- 46a** Optional scaffolding tube
- 47** Swivel Couplers SW $\text{Ø}48/48 \text{ mm ga}$

Concreting heights
(Fig. B3.01a – Fig. B3.01i)

Assembly

Assembly from bottom to top.

1. Fix horizontal scaffolding tubes to the existing couplings.
2. Fix diagonal scaffolding tubes to the horizontal scaffolding tubes or coupling tubes with the swivel couplings.
3. Depending on the respective influence width of the brace frames, optional scaffolding tubes can be left out or mounted during concreting and/or moving: see PERI Design Information for Brace Frame SB.

h = 2.50 – 3.00 m

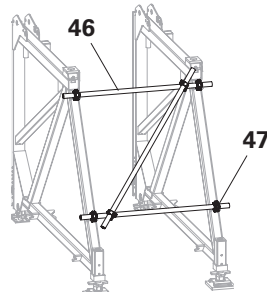

Fig. B3.01a

h = 2.50 – 4.00 m

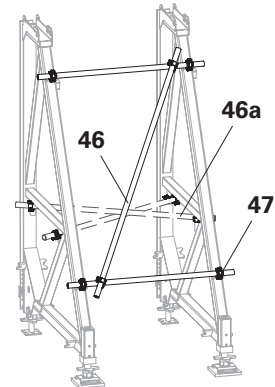

Fig. B3.01b

h = 2.75 – 4.00 m

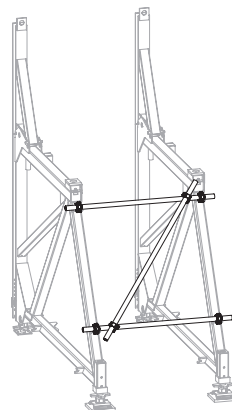

Fig. B3.01c

h = 3.75 – 5.00 m

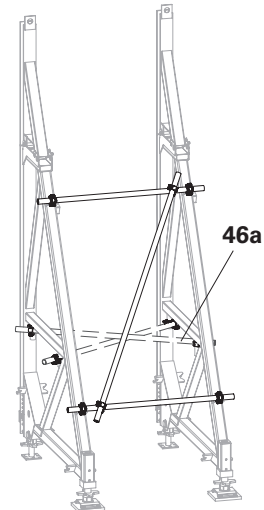

Fig. B3.01d

h = 3.75 – 6.00 m

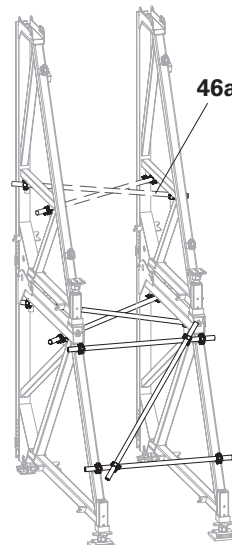

Fig. B3.01e

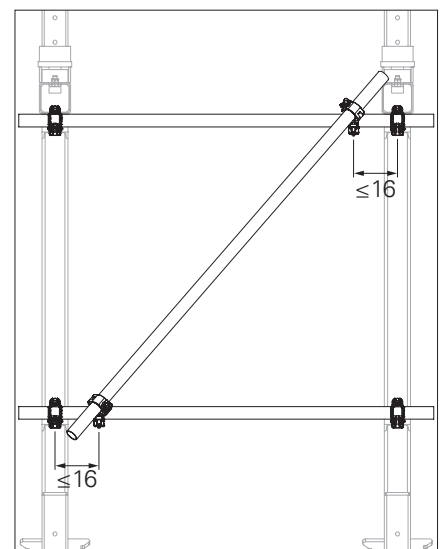

Fig. B3.01f

B3 Bracing SB-A0, A, B, C

h = 5.50 – 6.75 m

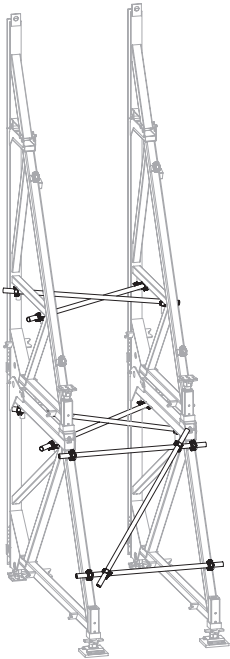

Fig. B3.01g

h = 6.75 – 8.75 m

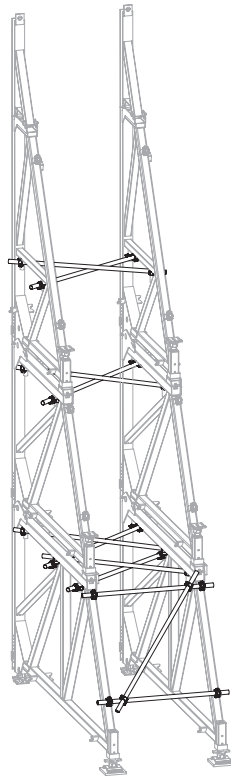

Fig. B3.01h

h = 8.75 m

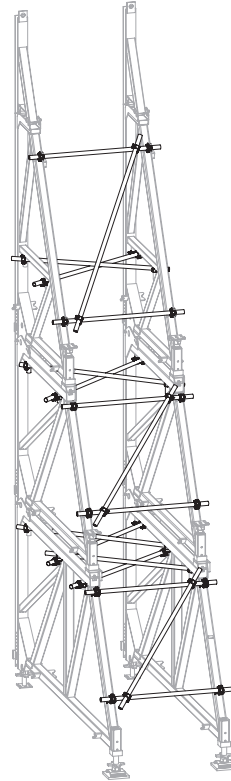

Fig. B3.01i

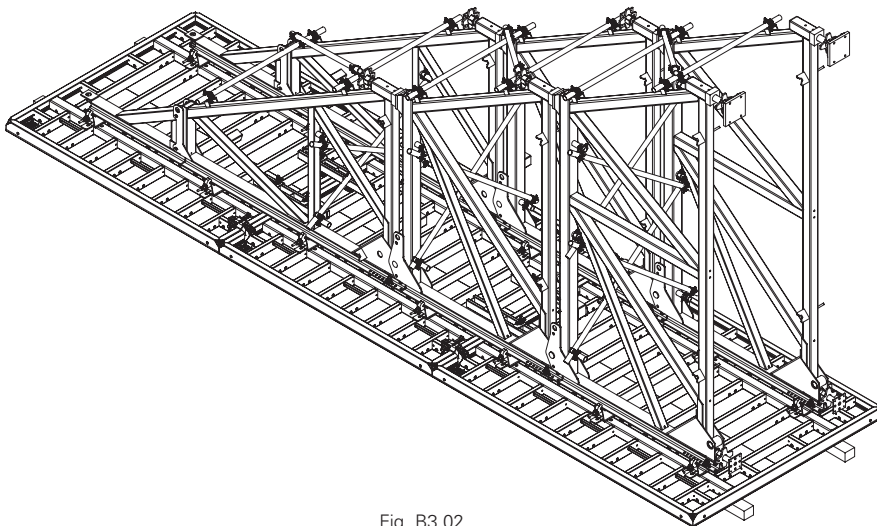

Fig. B3.02

With a crane



- For transport, always attach the movable units to the brace frame at the load-bearing points provided for this purpose!
- Observe the permitted load-bearing capacity!
- Do not use a crane to release the movable unit from concrete!
- The fastenings/wedges must be checked before all moving procedures. Where necessary, secure wedges using cotter pins or bolts.
- Minimum load-bearing capacity of the textile strap: 2.0 t.

Technical data

Permissible load-bearing capacity of load-bearing point SB-C

- 1.5 t with a lifting chain angle $\leq 15^\circ$.
- 2.5 t when lifting vertically.

Attachment

- Always attach brace frame combinations involving Brace Frame SB-C to SB-C.

(Fig. B4.01 + Fig. B4.03)

- Wrap textile strap around brace frame combinations without Brace Frame SB-C and attach to the crane.

(Fig. B4.02)

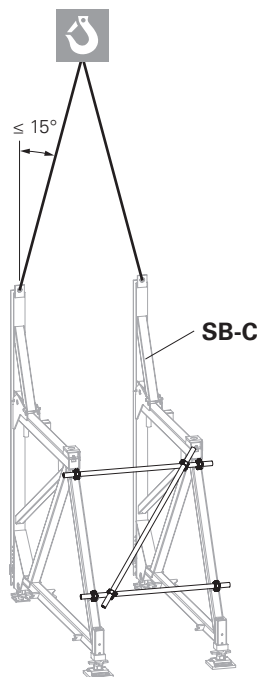

Fig. B4.01

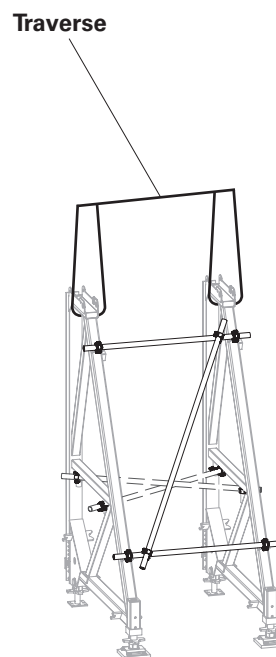

Fig. B4.02

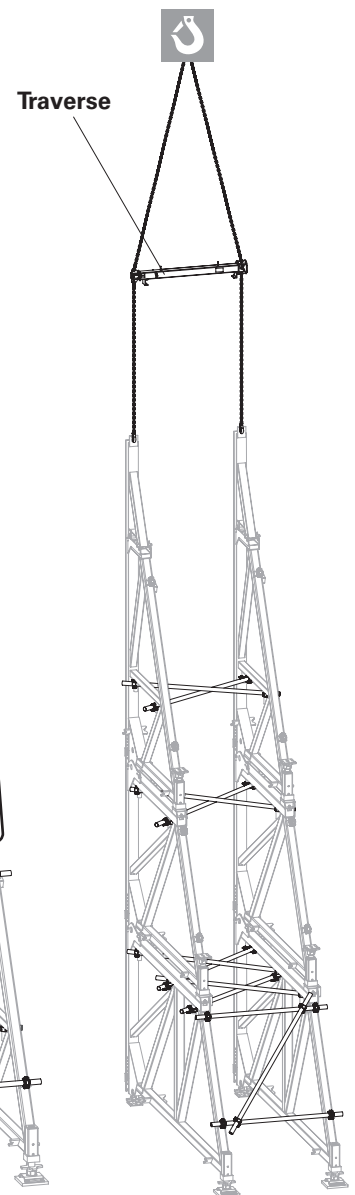

Fig. B4.03

Tables

Determining the weight of the movable units

The movable unit consists of:
2 x brace frames including diagonal bracing without anchoring.

The weight of the formwork and the connecting components must be added to the weight of the movable unit in question.

(Tab. B4.01 + Tab. B4.02)

Brace Frame combination	Weight / movable unit
SB-A0	925 kg
SB-A	700 kg
SB-B	625 kg
SB-A, C	800 kg
SB-A, B	1330 kg
SB-B, C	725 kg
SB-A, B, C	1400 kg
SB-A0, A, B	2175 kg
SB-A0, A, B, C	2275 kg

Tab. B4.01

Formwork	Weight per m ²
VARIO GT 24	60 kg
MAXIMO	75 kg
TRIO	75 kg
DOMINO Steel	60 kg
DOMINO Alu	30 kg
RUNDFLEX	Project-specific
RUNDFLEX Plus-2	Project-specific

Tab. B4.02

With Guide Roller SB-A0,A,B

Required components:

48 Guide Roller SB-A0,A,B 4x



Ensure stability!

Preparation

- Determine the centre of gravity of the dead weight (formwork and brace frame).
- Determine the overall centre of gravity S .
- Use an unfavourable wind load to determine the stability.
- Plan the overall centre of gravity S in such a way that it lies between the castors. (Fig. B4.05)
- If necessary, take additional ballast into account. (Fig. B4.06)

Assembly

1. To fit the Guide Roller SB-A0,A,B (**48**), the brace frame must be raised using the crane or using the spindles (**1.2 + 1.4**) on the brace frame.
 2. Push the wedge back (**48.1**).
 3. Slide the guide roller (**48**) over the profile tube from below and secure it with a wedge.
 - Front castor (**48**) between the inclines of the brace frame. (Fig. B4.04a)
 - Rear castor (**48**) as far back as possible. (Fig. B4.04b)
- (Fig. B4.04)

Concreting



For concreting, the castor should be spindled free of load. Load transfer takes place via the spindles on the brace frame.

Moving

Move the unit slowly and without the help of any power-operated traction means.

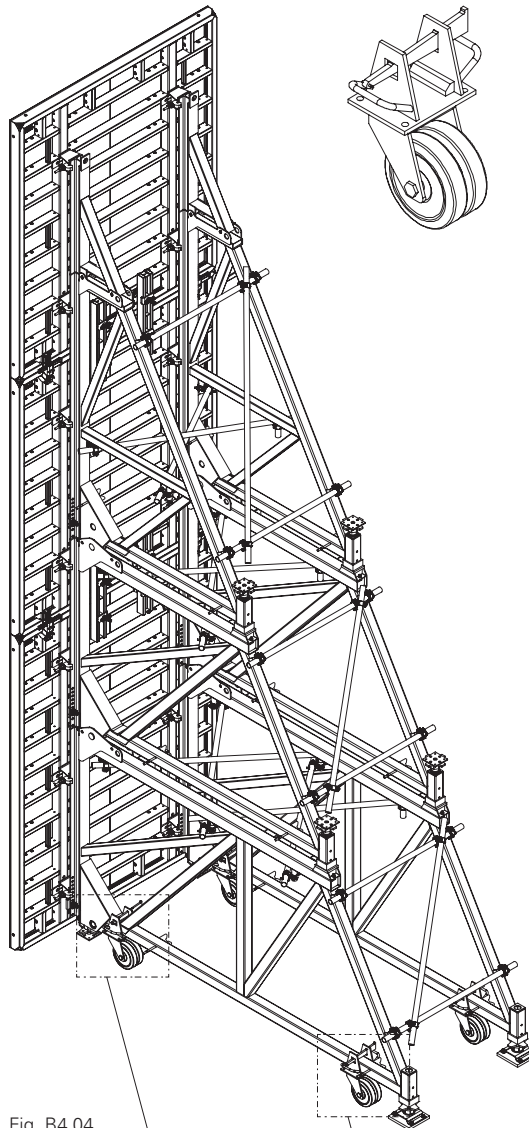

Fig. B4.04

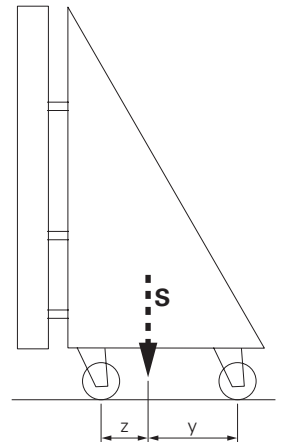

Fig. B4.05

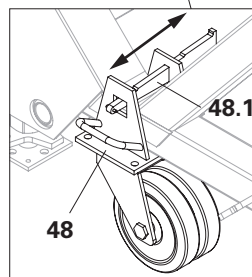

Fig. B4.04a

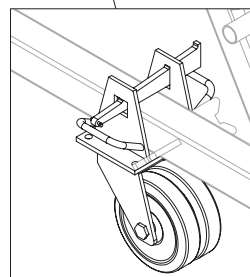

Fig. B4.04b

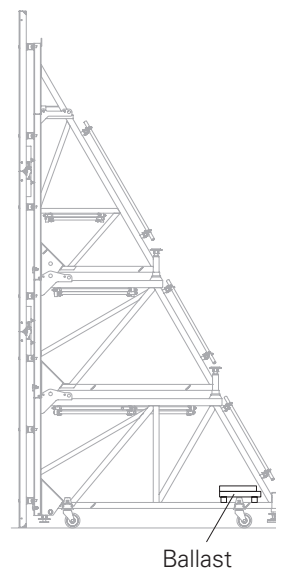

Fig. B4.06

General information



- The support (connection) for the elements must always be established at the point where the tie rod is installed for normal use (double-sided). Failure to do so results in the static system of the formwork unit being changed which could lead to large deformations; even breakage in extreme cases! Check the structural integrity of the formwork unit!
- When extending the formwork, take into account the information about the respective system.
- After each concreting or relocation operation, check the fasteners / wedges and ensure that they are permanently secured, if necessary.

Girder formwork VARIO GT 24, RUNDFLEX



- Fit the Brace Frame SB-2 horizontally and with a crane.
- Place the formwork unit on a clean, level and sufficiently load-bearing surface. Place squared timbers underneath.
- Depending on where the top edge of the brace frame lies, it may only be possible to construct the concreting platform using individual brackets, guardrail posts and decking and guardrail boards provided by the contractor.
- Take into account the permissible influence width; see PERI Design Information for Brace Frame SB.

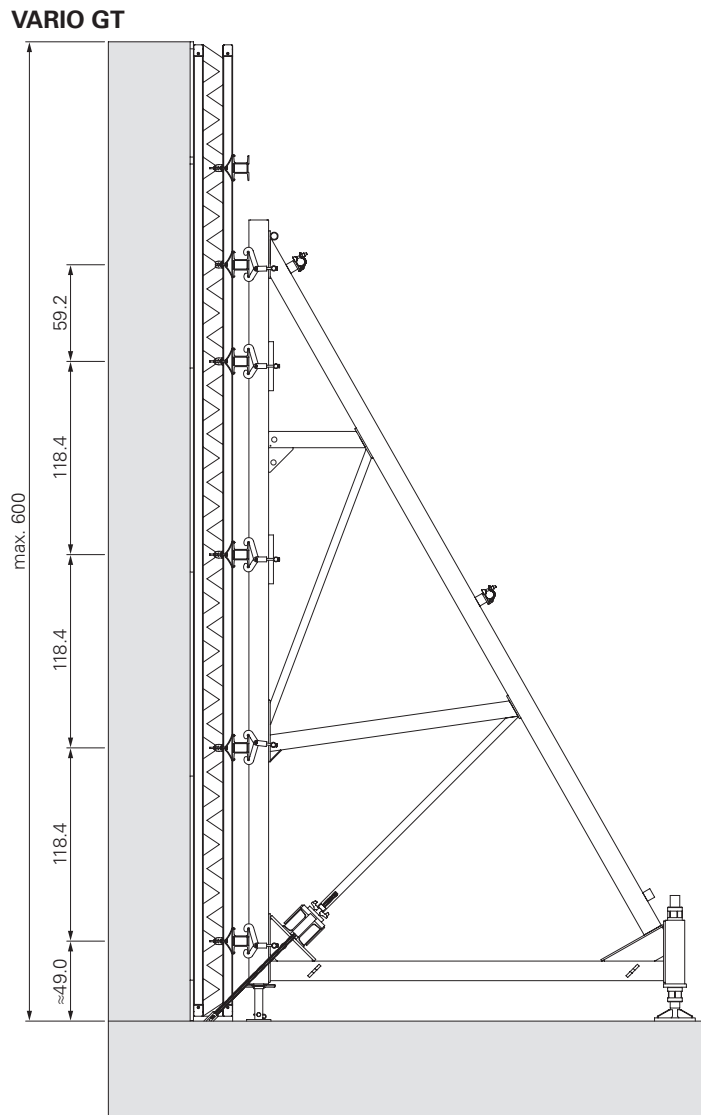
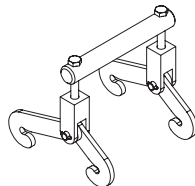

Fig. C1.01



Connecting to VARIO GT 24.
Max. concreting height h = 6.00 m.

Connecting to RUNDFLEX.
Max. concreting height h = 5.40 m.

Refer to the Instructions for Assembly and Use for the system.



Leave the brace frame attached to the crane until it is mounted.

Required components per ledger section:

49 Hook Strap SB-2 asymmetrical	1x
Alternatively:	
32 Hook Strap SB-2 ga	1x

VARIO GT

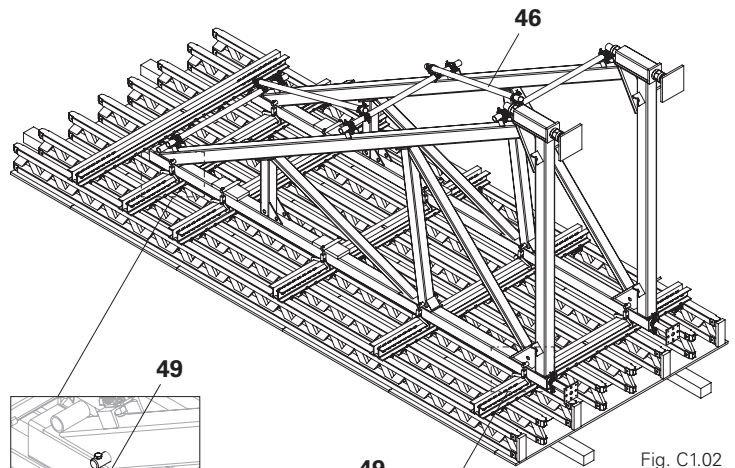

Fig. C1.02

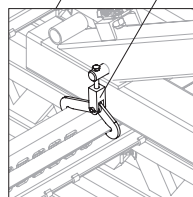

Fig. C1.02a

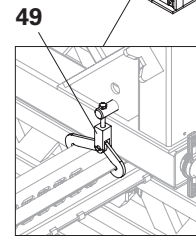

Fig. C1.02b

Connecting with Hook Strap SB-2 ga

- Swivel in the brace frame with the crane and place it on the steel waler/distribution waler.
 - Release one bolt, AF 19, on the hook strap and push the bolt through the hole on the brace frame. Tighten the bolt.
 - Attach the hook to the steel waler/distribution waler and tighten.
 - Attach hook straps to all steel walers/distribution walers.
- (Fig. C1.04a, C1.05a, C1.04b, C1.05b)
- Remove crane lifting gear.
 - Fit the second brace frame.
 - Brace the brace frames with scaffolding tubes (**46**) (horizontal and vertical).
 - Adjust the height of the movable unit with the spindles.

RUNDFLEX

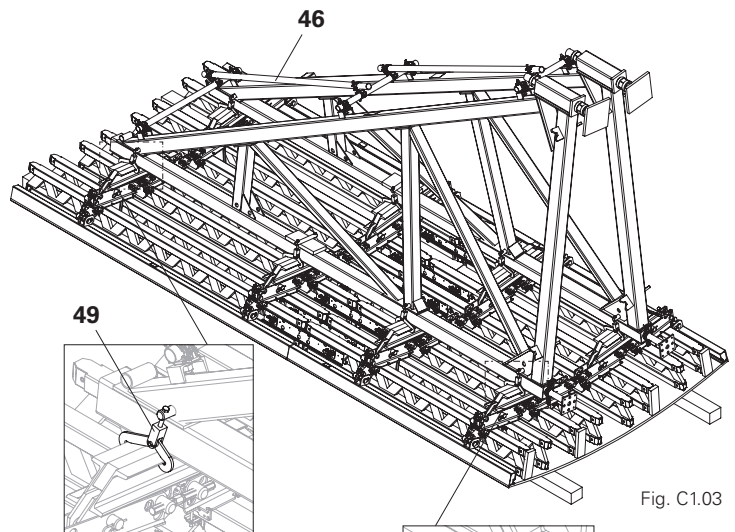

Fig. C1.03

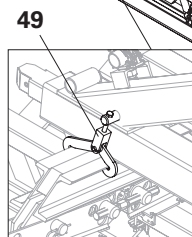

Fig. C1.03a

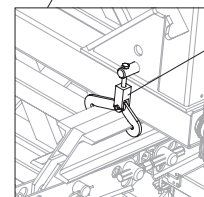

Fig. C1.03b

Erection

Erect, move, align and anchor the movable unit with textile straps and the crane, see Section "C2 Repositioning with the crane" on page 58.

Platforms

Do not mount concreting platforms until after erection.

MAXIMO, TRIO, DOMINO

MAXIMO, TRIO, DOMINO element



- Assembly can take place horizontally and with the crane.
- Place the formwork unit on a clean, level and sufficiently load-bearing surface. Place squared timbers underneath.
- Depending on the distance from the top edge of the brace frame to the top edge of the formwork, it may only be possible to construct the concreting platform with individual brackets, guardrail posts and decking and guardrail boards provided by the customer.
- Take into account the permissible influence widths; see PERI Design Information for Brace Frame SB.

Max. concreting height:

Vertical elements h = 5.40 m.

Horizontal elements h = 4.80 m.

Extended elements h = 6.00 m.

Refer to the Instructions for Assembly and Use for the system.

Required components for each connecting bar in the case of MAXIMO:

38	Hook Strap SB-2 ga	2x
42	Pin SB/MX ga	2x
43	Sleeve SB/MX ga	2x
44	Sleeve SB/MX WDMX*	2x
50	Connection Rail SB-2/TR, MX, D	1x

*with removable sealing

Required components for each connecting bar in the case of TRIO, DOMINO:

38	Hook Strap SB-2 ga	2x
45	Pin SB/TR, D ga	2x
50	Connection Rail SB-2/TR, MX, D	1x
Alternatively:		
49	Hook Strap SB-2 asymmetrical	1x

Vertical

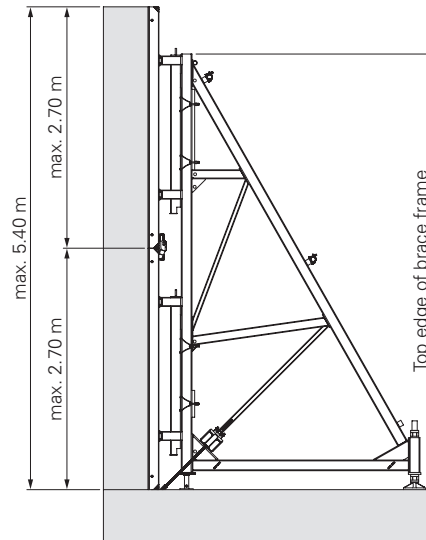

Fig. C1.04

Horizontal

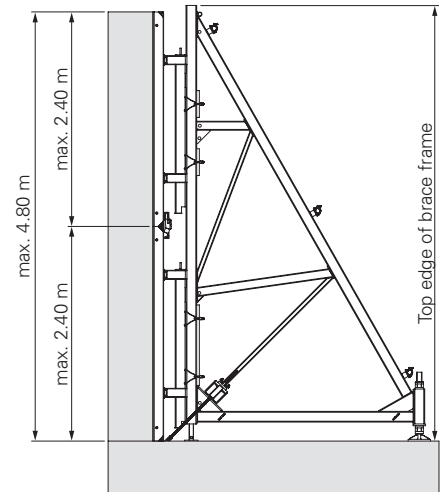

Fig. C1.05

C1 Connecting to system SB-2

Additional components for each brace frame in the case of height extension:

9 Tie Rod DW15	4x
13 Wingnut Pivot Plate DW15 ga	4x
50 Connection Rail SB-2/TR,MX,D	1x
51 Board 3 x 14	1x
52 Compensation Waler-3 MAR 85	2x
53 Hook Tie Head DW15 ga	4x

MAXIMO, TRIO, DOMINO elements extended

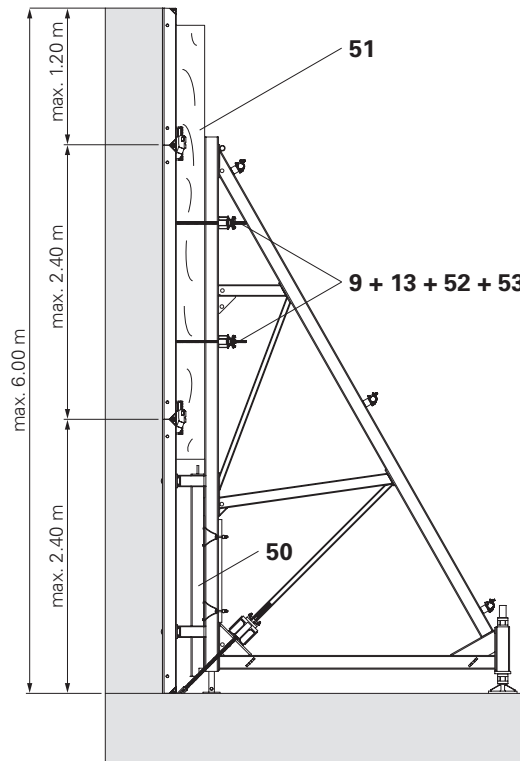

Fig. C1.06

C1 Connecting to system SB-2

Connecting a Connection Rail SB-2/TR,MX,D to an element



Refer to the Instructions for Assembly and Use for the formwork system used.

Preparation

1. Position the elements or element unit on trestles. Element connections: see Instructions for Assembly and Use of the system.
2. Insert sleeves (43/44) into the tie holes of the element; only for MAXIMO.
3. Set the Connection Rail SB-2/TR,MX,D (50) down with its connections on the tie holes.
4. Insert Pin SB/MX ga (42) or Pin SB-TR.D (45) from below.
5. Fix Connection Rail SB-2/TR,MX,D (50) to both tie holes with wedges (50.1).
6. Fix an additional Connection Rail SB-2/TR,MX,D (50) to the tie holes. (Fig. C1.07 + Fig. C1.07a)

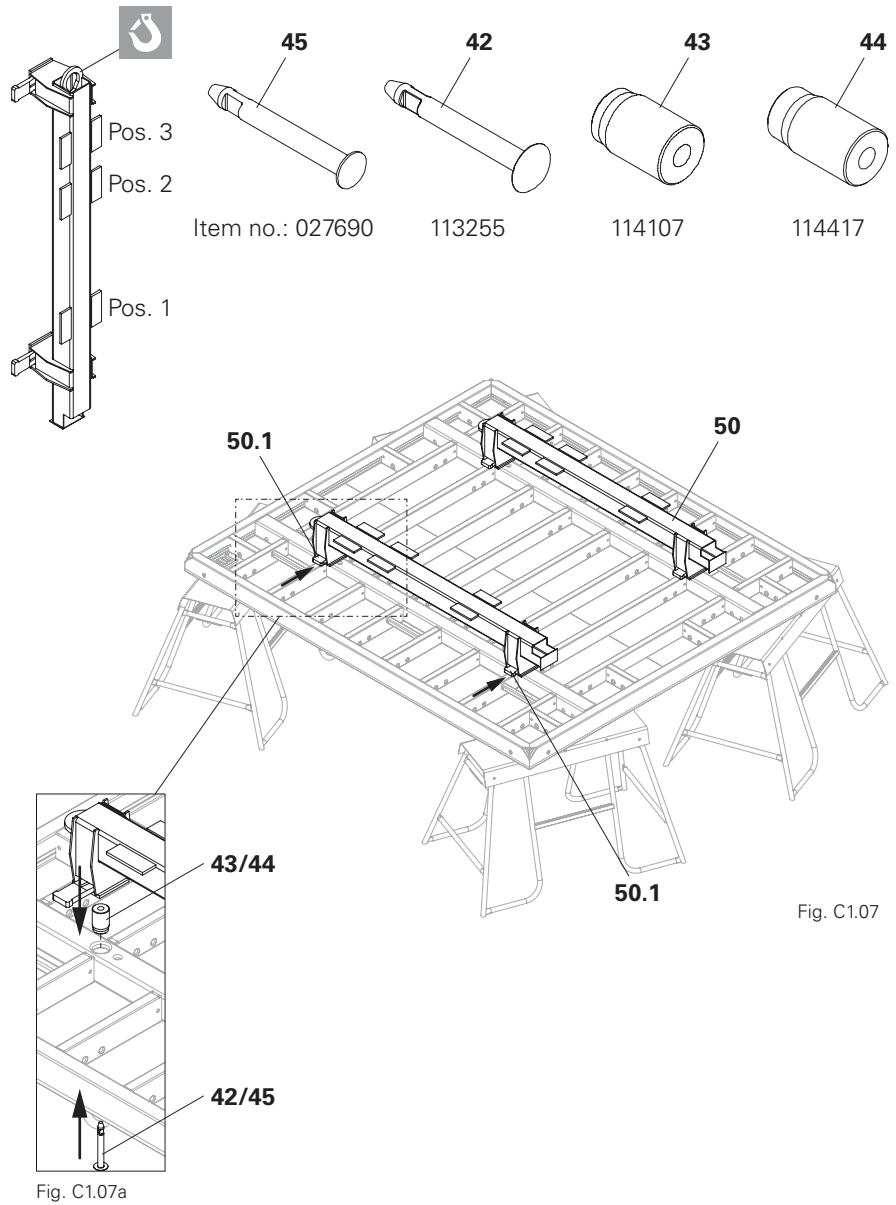

Fig. C1.07

Fig. C1.07a

MAXIMO, TRIO, DOMINO

Mounting the brace frame

1. Position the elements or element unit on squared timber.
2. Swing the brace frame into position with the crane and set it down on the Connection Rail SB-2/TR,MX,D (50). Top edge of brace frame = top edge of Connection Rail SB.
3. Attach two Hook Straps SB-2 ga (38) to the lugs (pos. 2 + pos. 3) of the Connection Rail SB-2/TR,MX,D (50) and secure with nuts. Place a board underneath to prevent slipping. (Fig. C1.08a)
4. Remove crane lifting gear.
5. Fit the second brace frame.
6. Brace the brace frames with scaffolding tubes (46) (horizontal and vertical).
7. Mount concreting platforms.
8. Adjust the height of the movable unit with the spindles.

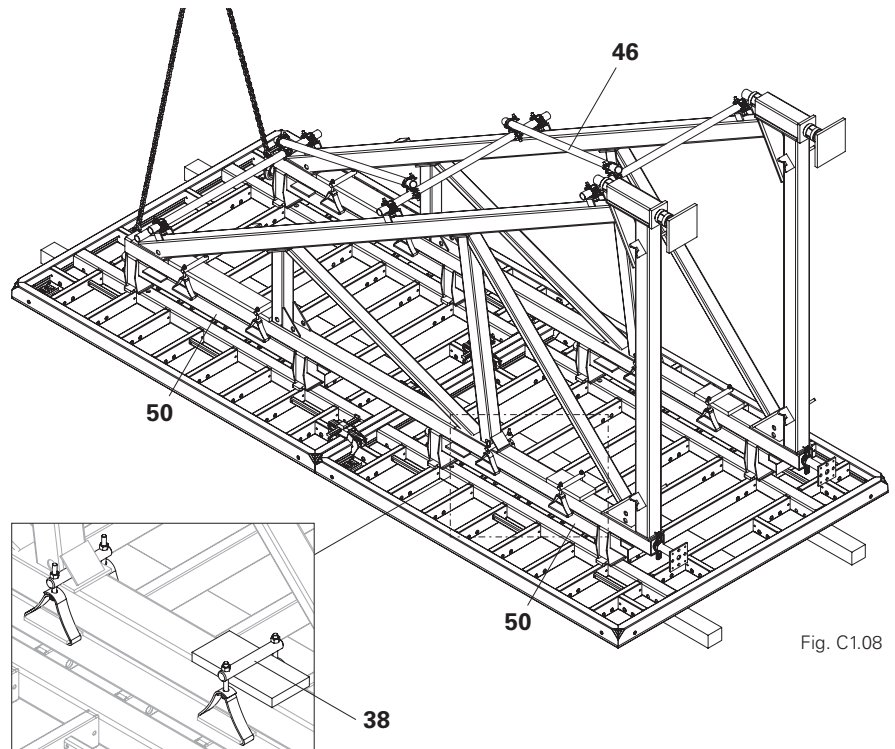

Fig. C1.08

Fig. C1.08a

Erection

Permissible load-bearing capacity of load-bearing point: 1.0 t with a crane sling angle of $\leq 15^\circ$.

Erect, move, align and anchor the movable unit with the crane by the load-bearing points.

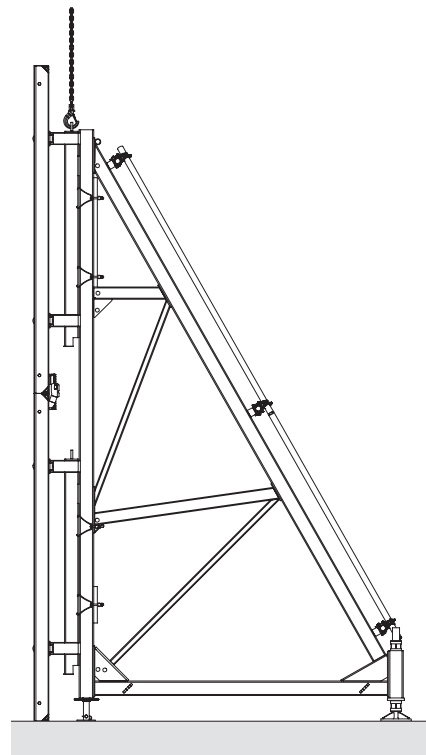

Fig. C1.09



- Always transport the movable units on the intended load bearing points!
- Observe the permitted load-bearing capacity!
- Do not use a crane to release the movable unit from concrete!
- The fastenings/wedges must be checked before all transport movements. Where necessary, secure wedges using cotter pins or bolts!



- Remove the concreting platform before moving.
- Only attach the unit to the attachment points provided.

Technical data

- Permissible load-bearing capacity of the Connection Rail SB-2/TR,MX,D: 1.0 t.
- Minimum load-bearing capacity of the round sling: 1.0 t.

Attachment

Movable unit with Brace Frame SB-2 and Connection Rail SB-2/TR,MX,D:

Always attach to the Connection Rail SB-2/TR,MX,D (50). (Fig. C2.01)

Movable unit with Brace Frame SB-2 and Hook Strap SB-2 asymmetric / SB-2:

Wrap textile strap (37) around the brace frame and attach to the crane. (Fig. C2.02)

Tables

Determining the weight of the movable units

The movable unit consists of:
2 x brace frames including diagonal bracing without anchoring.

The weight of the formwork and the connecting components must be added to the weight of the movable unit in question.
(Tab. C2.01 + Tab. C2.02)

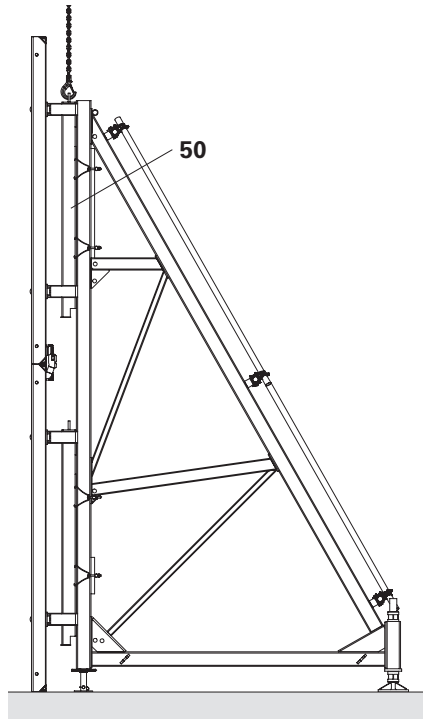

Fig. C2.01

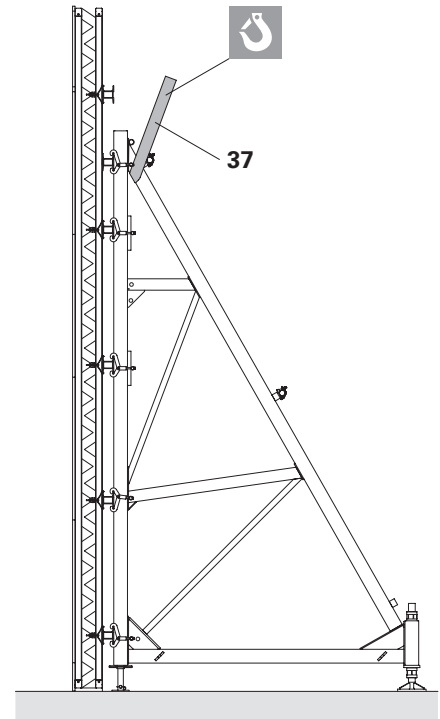

Fig. C2.02

Brace Frame combination	Weight / movable unit
SB-2	800 kg

Tab. C2.01

Formwork	Weight per m ²
VARIO GT 24	60 kg
MAXIMO	75 kg
TRIO	75 kg
DOMINO Steel	60 kg
DOMINO Alu	30 kg
RUNDFLEX	Project-specific
RUNDFLEX Plus-2	Project-specific

Tab. C2.02

Pre-assembly

The Brace Frame SB VARIOKIT is used for single-sided forming of walls up to 3.00 m.

It is assembled on site using VARIOKIT components.



- Permissible influence widths must be determined on a project-specific basis.
- Refer to the Instructions for Assembly and Use for the formwork system used.

Required components for each brace frame:

54 Steel Waler SRU 247 U120	1x
55 Steel Waler SRU 122 U120	1x
56 Heavy Duty Spindle SLS 140-240	1x
57 Corner Connector VARIOKIT SRU	1x
58 Fitting Pin Ø21x120 mm	5x
59 Cotter Pin 4/1 ga	5x

Mounting the brace frame

1. Set the Steel Waler SRU 122 U120 (**55**) down with the row of holes facing upwards.
2. Fix the Corner Connector VARIOKIT SRU (**57**) to the first and third hole of the Steel Waler SRU 122 U120 (**55**) with 2x Fitting Pins Ø21x120 mm (**58**) and Cotter Pin 4/1 ga (**59**). (Fig. D1.01b)
3. Fix Steel Waler SRU 247 U120 (**54**) to the lowest hole of the Corner Connector VARIOKIT SRU (**57**) with Fitting Pin Ø21x120 mm (**58**) and Cotter Pin 4/1 ga (**59**), with the slots facing the element. (Fig. D1.01b)
4. Secure the components with the crane to prevent them from falling over.

MAXIMO, TRIO

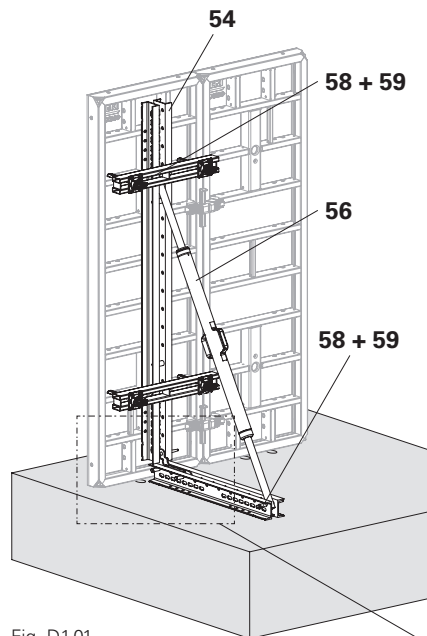

Fig. D1.01

Top view

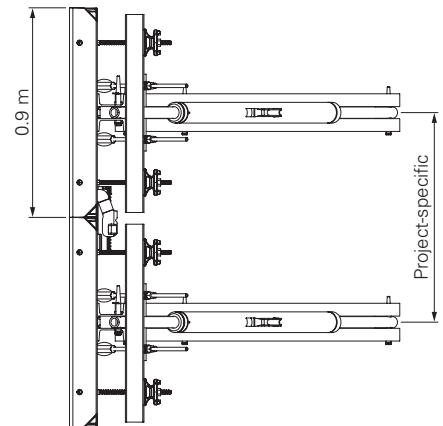

Fig. D1.01a

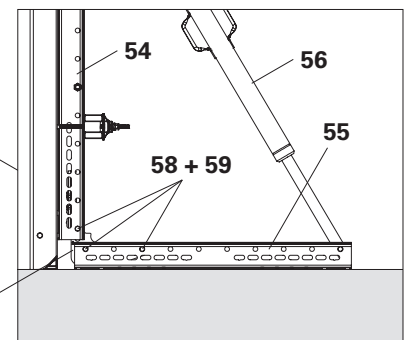

Fig. D1.01b

5. Unspindle the Heavy Duty Spindle SLS 140-240 (56) and fix it to the Steel Waler SRU 247 U120 (54) and Steel Waler SRU 122 U120 (55) with Fitting Pin Ø21x120 mm (58) and Cotter Pin 4/1 ga (59). (Fig. D1.01 – Fig. D1.02b)
6. Spindle the Steel Waler SRU 247 U120 (54) vertically.
7. Attach the brace frame to the secured element.

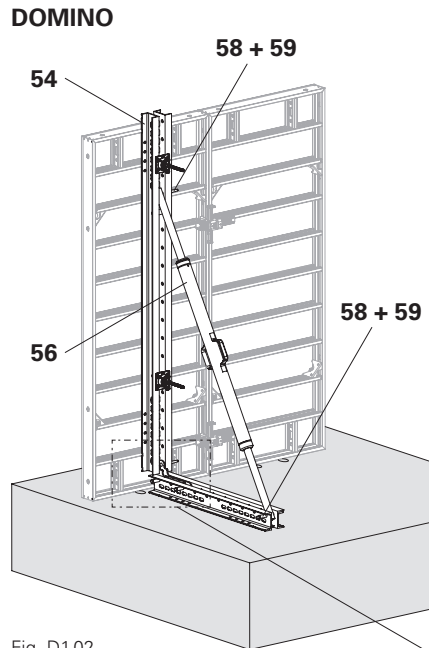

Fig. D1.02

Top view

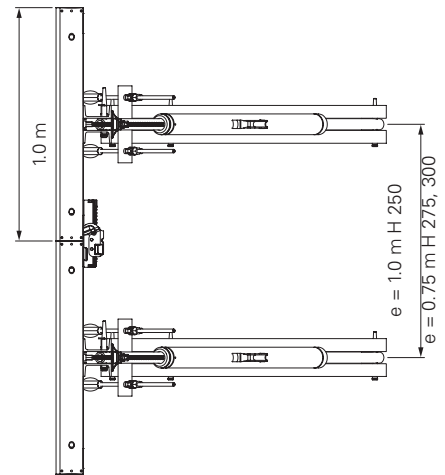

Fig. D1.02a

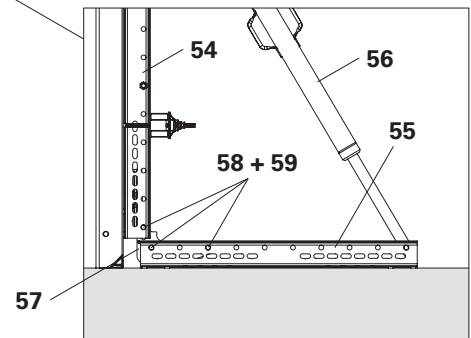

Fig. D1.02b

Assembling the formwork

Panel Formwork MAXIMO, TRIO

Required components for each brace frame:

13	Wingnut Pivot Plate DW15 ga	4x
60	Waler 85	2x
61	Hook Tie Head DW15 ga	4x

Connecting with tie bracket and corner connector

1. Lay Waler 85 (60) over Steel Waler SRU 247 U120 (54).
2. Push two Hook Tie Heads DW15 ga (61) through Waler 85 (60) and hook them into the element.
3. Secure with Wingnut Pivot Plates DW15 ga (13).
4. Fix the second Waler 85 (60) into place in the same way. (Fig. D1.03)

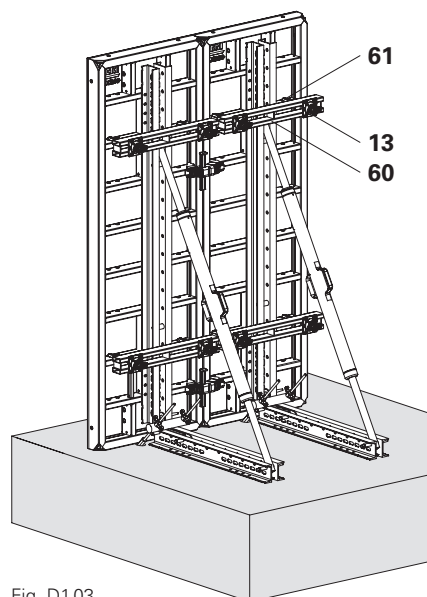

Fig. D1.03

DOMINO Panel Formwork

Required components for each brace frame:

13 Wingnut Pivot Plate DW15 ga	4x
61 Hook Tie Head DW15 ga	4x

Connecting with tie bracket and corner connector

1. Push Hook Tie Head DW15 ga (**61**) through Steel Waler SRU 247 U120 (**54**) and hook it into the element.
2. Secure with Wingnut Pivot Plates DW15 ga (**13**).
3. Fix the second Hook Tie Head DW15 ga (**61**) into place in the same way.
(Fig. D1.04)

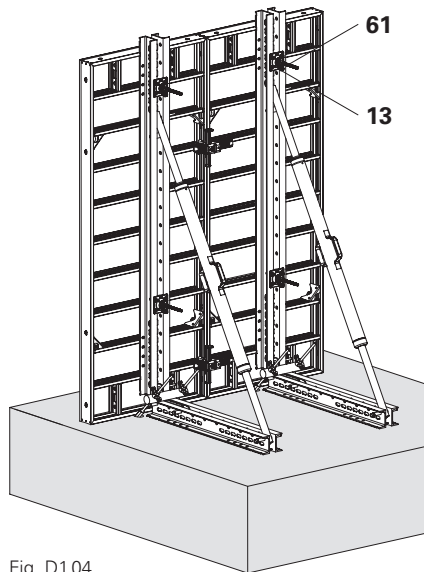

Fig. D1.04

Anchoring



Other anchoring systems than those shown here require separate static proof!

Version with Double Anchor Tie Yoke DSW

Permissible tension force $2 \times 90 \text{ kN} = 180 \text{ kN}$.

Load table: see PERI Design Information for SB Brace Frame.

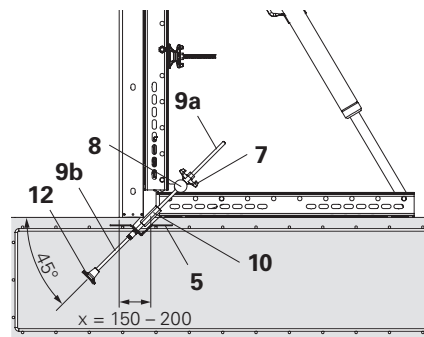

Fig. D1.05

Reusable tie parts:

7 Wingnut DW15 ga	2x
8 Double Anchor Tie Yoke DSW	1x
9a Tie Rod DW15	2x
10 Hex-Nut DW15 SW30 108 mm ga	2x

Lost tie parts:

5 V-Tie Holder DW15	2x
9b Tie Rod DW15	2x
11 Anchorage Loop DW15	1x
12 Threaded Anchor Plate DW15	2x

(Fig. D1.05 + Fig. D1.06)

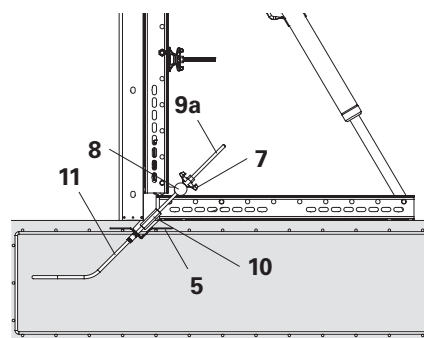

Fig. D1.06

Moving



When moving, always separate the brace frame from the formwork unit, and move them separately.

Disassembly

1. Remove anchoring. (Fig. D1.07a)
2. Temporary secure elements with push-pull props to prevent tipping over.
3. Remove Waler 85 (**60**), Hook Tie Head DW15 ga (**61**) and Wingnut Pivot Plates DW15 ga (**13**). (Fig. D1.07)
4. Move the Brace Frame VARIOKIT with round sling (**37**).
5. Move the formwork unit with the lifting hook of the respective system - take into account Instructions for Use (Fig. D1.07 + Fig. D1.07a)

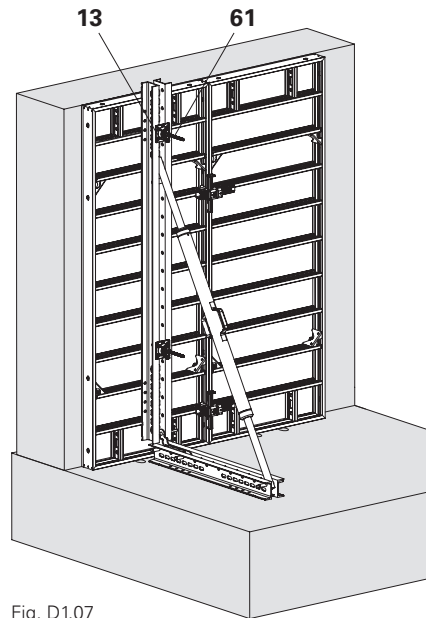

Fig. D1.07

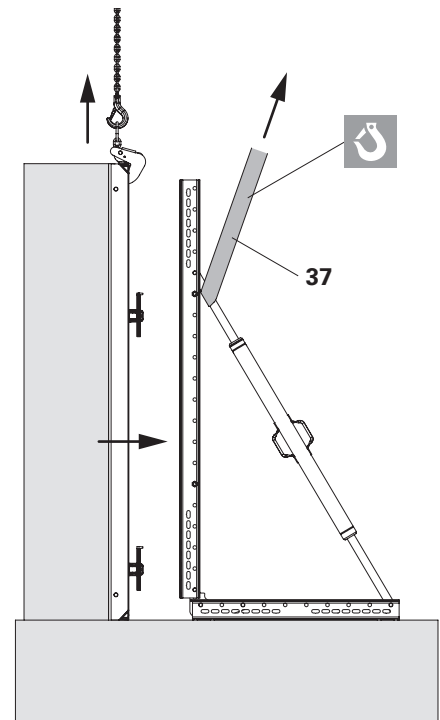

Fig. D1.07a

Application

DOMINO 250
DOMINO 275
DOMINO 300
(Fig. D1.08)

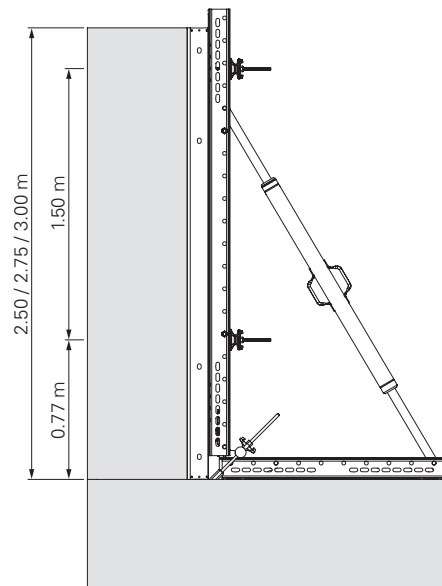

Fig. D1.08

MAXIMO 270
TRIO 270
(Fig. D1.09)

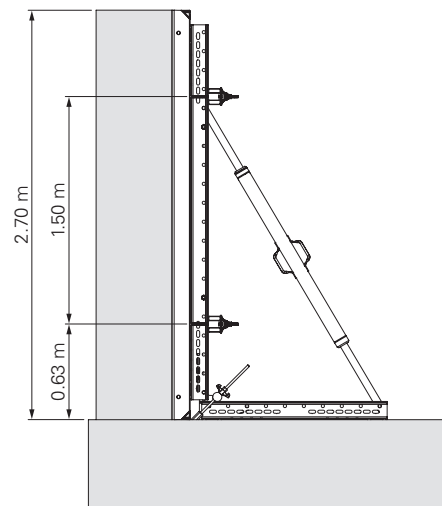

Fig. D1.09

Pre-assembly

The Brace Frame SB SCS is used for single-sided forming of walls up to 3.90 m. It is assembled on site using SCS components.



- Take into account the permissible influence widths "e"; see PERI Design Information for Single-sided SCS Climbing System.
- Refer to the Instructions for Assembly and Use for the formwork system used.

Required components for each brace frame:

74 Strongback SCS 325	1x
75 Spindle Connector SCS Ø26/21 mm	1x
76 Height Adjusting Unit CB SCS	1x
77 Waler Fixation U100/U120	2x
78 Starter Bar SCS	1x
81 Heavy Duty Spindle SCS 198-250	1x

Mounting the brace frame

1. Position Starter Bar SCS (**78**).
2. Fit Strongback SCS 325 (**74**) onto Starter Bar SCS (**78**) with Fitting Pin Ø26x120 mm (**78.1**) and Cotter Pin 5/1 ga (**78.2**).
3. Adjust the length of the Heavy Duty Spindle SCS 198-250 (**81**).
4. Fit Heavy Duty Spindles SCS 198-250 (**81**) with 1x Fitting Pin Ø26x120 mm (**81.1**) and Cotter Pin 5/1 ga (**81.2**) in each case:
 - to Spindle Connector SCS Ø26/21 mm (**75**),
 - to Starter Bar SCS (**78**).

Assembling the formwork

1. Lay Strongback SCS 325 (**74**) on the steel walers of the VARIO GT 24 element in accordance with "e".
2. Fit Waler Fixation U100/U120 (**77**) and secure in position by tightening the quick jack nut.

VARIO GT 24

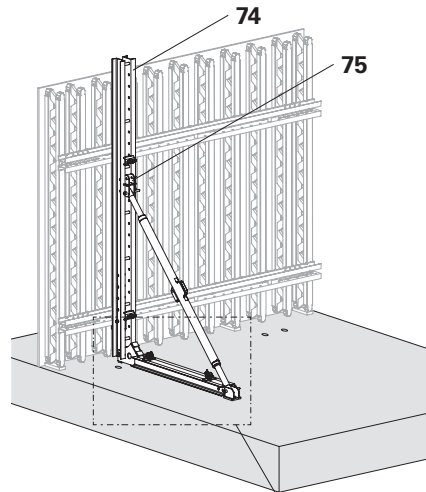

Fig. D2.01

Top view

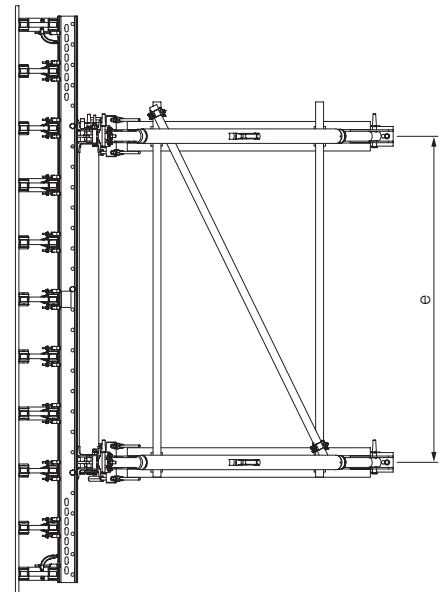

Fig. D2.01a

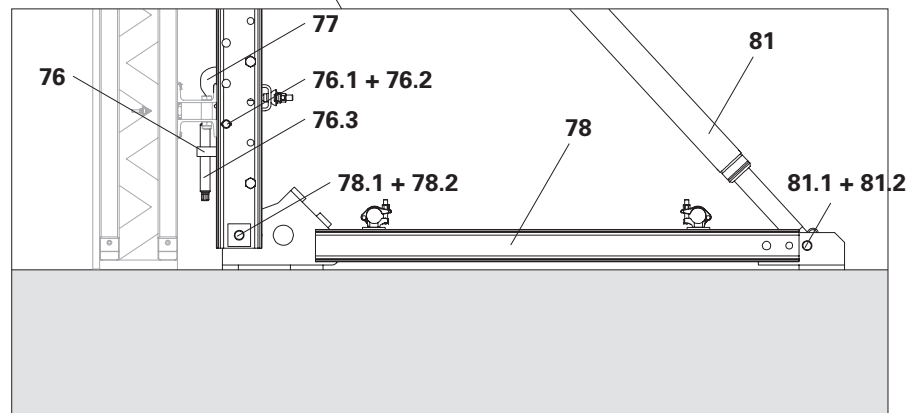

Fig. D2.02

3. Secure the Height Adjusting Unit CB SCS (**76**) on Strongback SCS 325 (**74**) with bolt Ø25x180 mm (**76.1**) and Cotter Pin 5/1 ga (**76.2**). (Fig. D2.02)
4. Turn the spindle (**76.3**) of the Height Adjusting Unit CB SCS (**76**) against the formwork waler.
5. Erect the unit and position it in the intended location.

Anchoring



Other anchoring systems than those shown here require separate static proof!

Load table: see
PERI Design Information for
SB Brace Frame.

Version with Double Anchor Tie Yoke DSW

- Permissible tension force 2 x 90 kN = 180 kN.
- Tie spacing = 20 cm.

Reusable tie parts:

7	Wingnut DW15 ga	2x
9a	Tie Rod DW15	2x
10	Hex-Nut DW15 SW30 108 mm ga	2x
79	Anchor Bolt SW24 Ø14/20x130 mm	1x
80	Tie Yoke SCS Ø60 mm 200 mm	1x

Lost tie parts:

5	V-Tie Holder DW15	2x
9b	Tie Rod DW15	2x
12	Threaded Anchor Plate DW15	2x

Version with Steel Waler SRU

- Permissible tension force
2 x 90 kN = 180 kN.
- Max. tie spacing = 35 cm.



The tie must not be fitted in the slotted hole area of the Steel Waler SRU otherwise the force will be reduced to 70 kN per Tie Rod DW 15.

Reusable tie parts:

9a	Tie Rod DW15	2x
10	Hex-Nut DW15 SW30 108 mm ga	2x
13	Wingnut Pivot Plate DW15 ga	2x

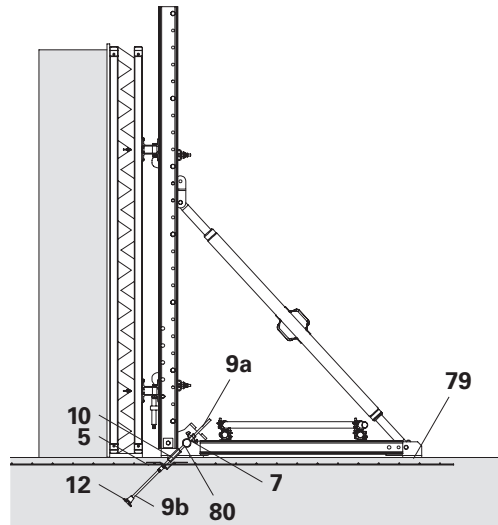

Fig. D2.03

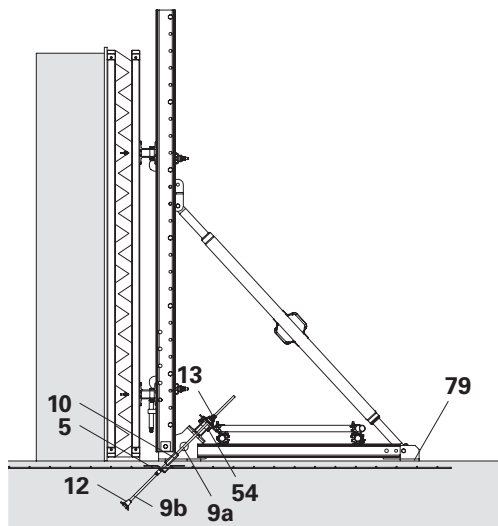

Fig. D2.04

79	Anchor Bolt SW24 Ø14/20x130 mm	1x
54	Steel Waler SRU 247 U120	1x

Lost tie parts:

5	V-Tie Holder DW15	2x
9b	Tie Rod DW15	2x
12	Threaded Anchor Plate DW15	2x

Moving



Pick up units by the spacer in the steel waler.
(Fig. D2.05 + Fig. D2.05a)

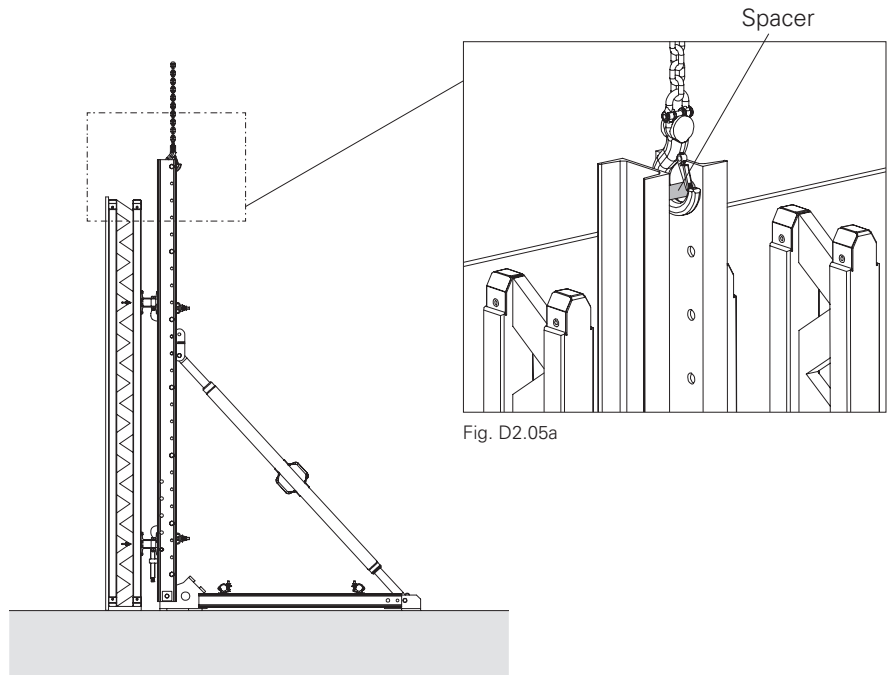

Fig. D2.05

Application

VARIO GT 24 with double tie yoke
(Fig. D2.06)

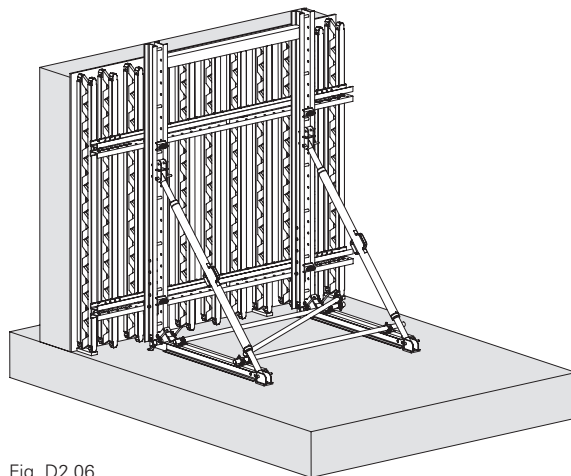

Fig. D2.06

**VARIO GT 24 with Steel Waler
Universal SRU U 120**
(Fig. D2.07)

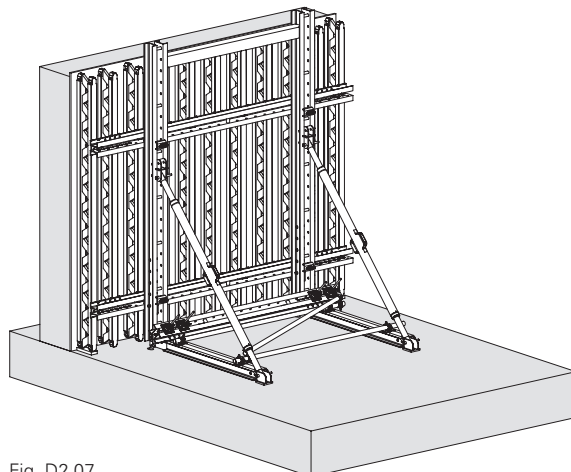

Fig. D2.07



- Always attach movable units to the brace frame when transporting.
- Always use the available load-bearing points as well as textile straps!
- Observe the permissible load-bearing capacities!
- The fastenings/wedges must be checked before all transport movements. Where necessary, secure wedges using cotter pins or bolts!

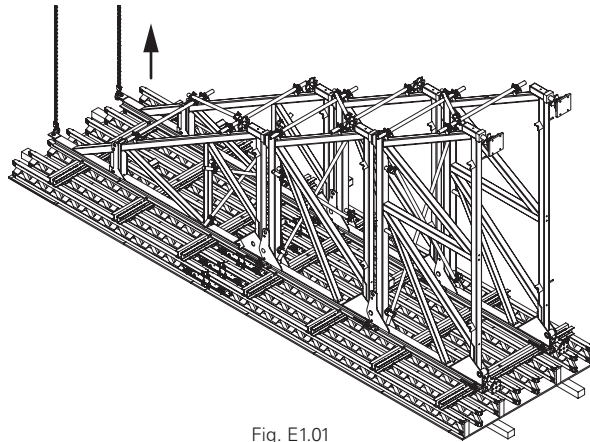

Fig. E1.01

Procedure

1. Attach the movable unit to the crane (Fig. E1.01).
2. Set it upright, taking care not to damage the lower edge of the formlining.
3. Place the movable unit on a sufficiently load-bearing surface, and align using the spindles (1.2 + 1.4).
4. Ensure stability and release the crane slings from a safe workplace.
5. Position additional movable units.
6. Fit panel connections between the movable units: see the Instructions for Assembly and Use for the formwork system, e.g. VARIO GT 24 Coupling VKZ 99.
7. Fit brace frames to the tie components in the substrate using recoverable tie components. See Section "A3 Tie technology" on page 27. (Fig. E1.02 + Fig. E1.02a)



Are the element connections and tie components firmly connected?

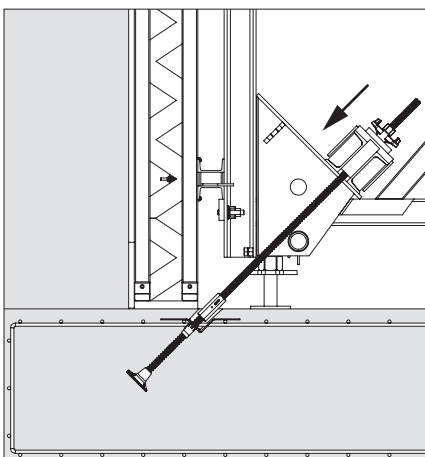

Fig. E1.02a

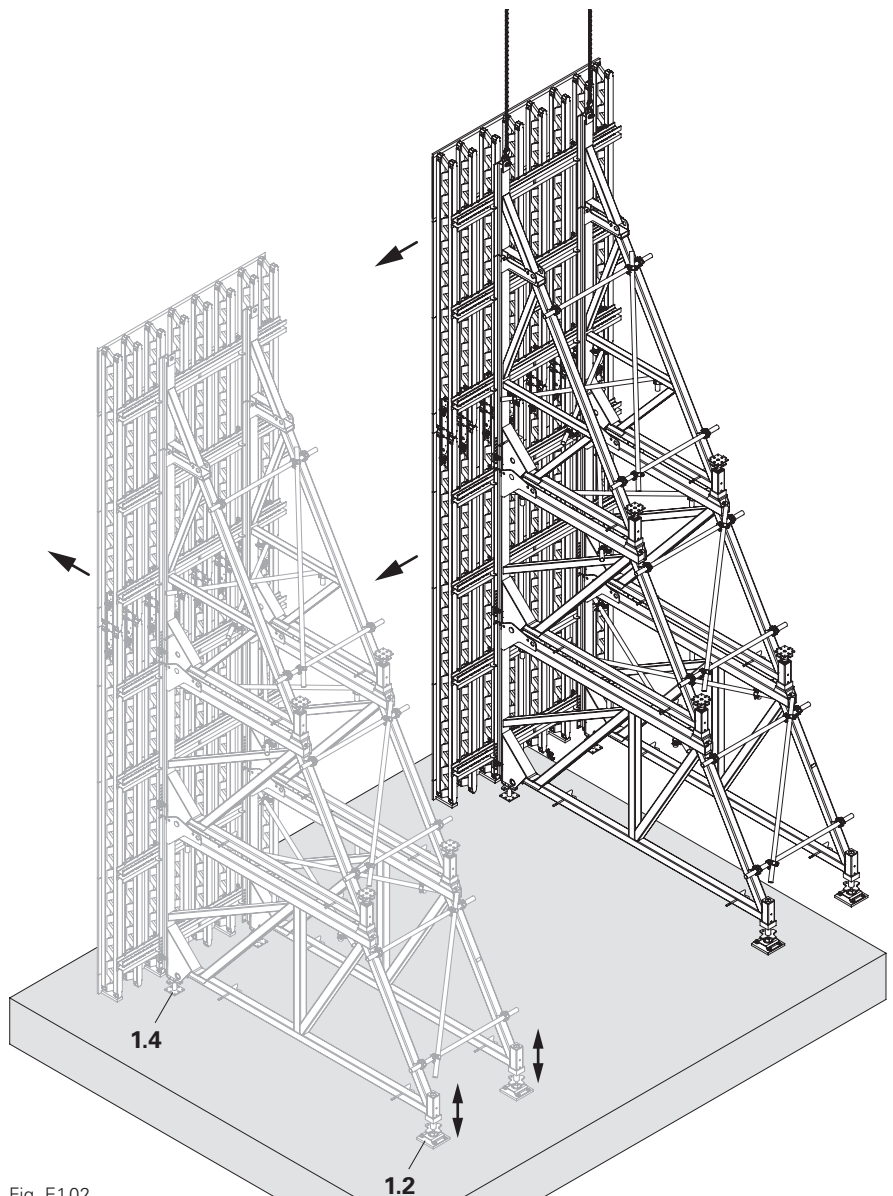

Fig. E1.02

Releasing Tie System DW 15

With Double Anchor Tie Yoke DSW

Releasing

1. Unscrew Wingnut DW15 ga (7).
2. Unscrew Hex-Nut DW15 SW30 108 mm ga (10).
3. Remove Wingnut DW15 ga (7), Tie Rod DW15 (9) and Hex-Nut DW15 SW30 108 mm ga (10).
4. Remove Double Anchor Tie Yoke DSW (8).

(Fig. E2.01)

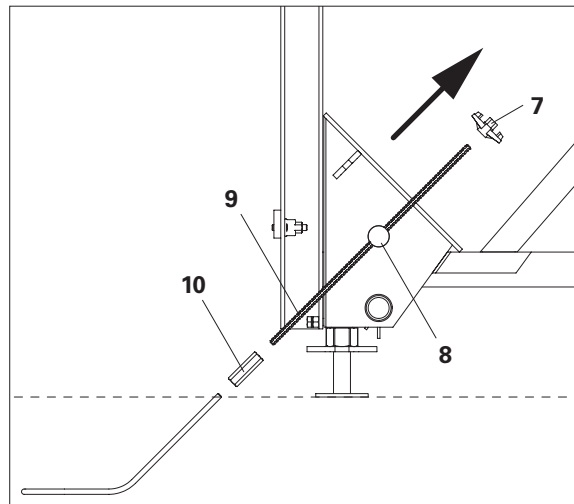

Fig. E2.01

With Anchor Waler U140

Releasing

1. Unscrew Wingnut Pivot Plate DW15 ga (13).
2. Remove Anchor Plate SB DW26 (14) and Anchor Waler U140 (15 / 16).
3. Unscrew Hex-Nut DW15 SW30 108 mm ga (10).
4. Remove Hex-Nut DW15 SW30 108 mm ga (10) and Tie Rod DW15 (9).

(Fig. E2.02)

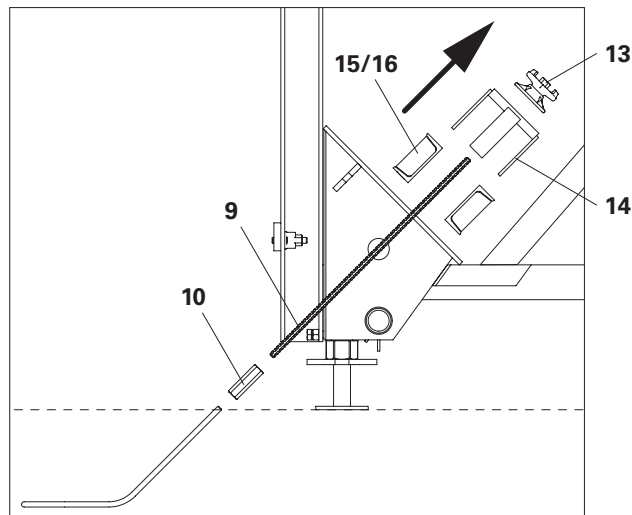

Fig. E2.02

Releasing Tie System DW 20

With Anchor Waler U160

Releasing

1. Unscrew Wingnut DW20 ga (17).
2. Remove Anchor Plate SB DW26 (14), Counterplate DW20 120x120x20 mm (18) and Anchor Waler 55 U160 (19).
3. Unscrew Hex-Nut DW20 SW36 110 mm ga (21).
4. Remove Hex-Nut DW20 SW36 110 mm ga (21) and Tie Rod DW20 (20).

(Fig. E2.03)

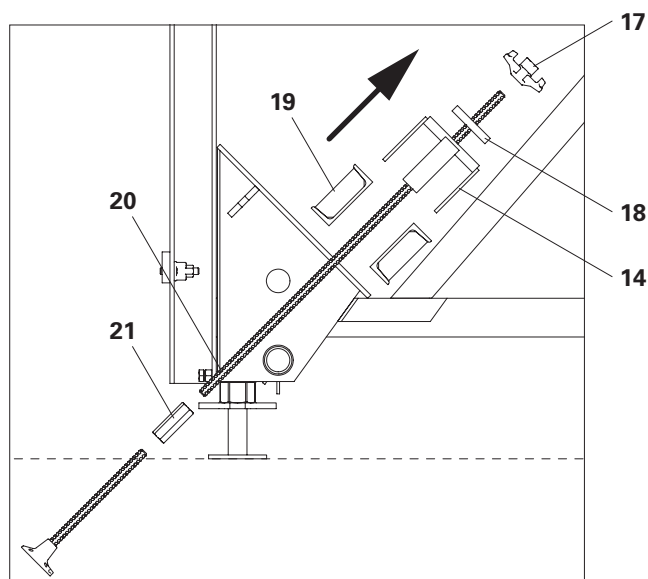

Fig. E2.03

Releasing Tie System DW 26

With Anchor Waler U160

Releasing

1. Turn bolt ISO 4017-M30x050-8.8 (24.1) counterclockwise (AF 46).
→ Hex. Nut DW26 SW46 80 mm (23) is loosened.
(Fig. E2.04 – Fig. E2.05a)
2. Unscrew Hex-Nut DW26 SW46 80 mm ga (23).
3. Remove Anchor Rele. Plate SB DW26 cpl (24), Hex-Nut DW26 SW46 80 mm ga (23) and Anchor Waler 55 U160 (19).
4. Unscrew Hex-Nut DW26 SW46 150 mm ga (26).
5. Remove Hex-Nut DW26 SW46 150 mm ga (26) and Tie Rod DW26 (25).
(Fig. E2.06)

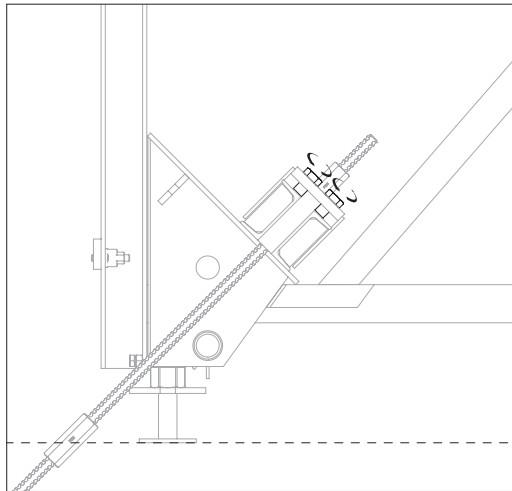

Fig. E2.04

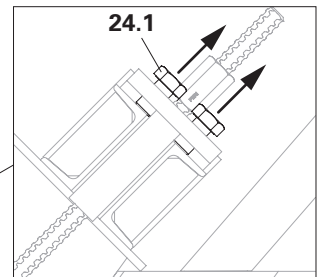

Fig. E2.05a

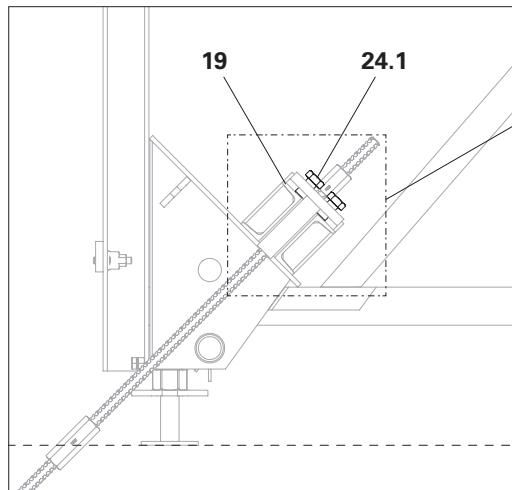

Fig. E2.05

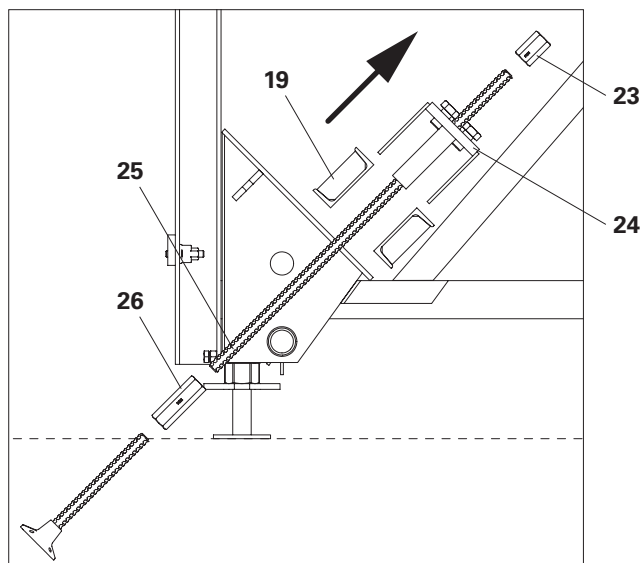

Fig. E2.06

Moving the unit



- Always attach movable units to the brace frame when transporting.
- Always use the available load-bearing points as well as textile straps!
- Observe the permissible load-bearing capacities!
- The fastenings/wedges must be checked before all transport movements. Where necessary, secure wedges using cotter pins or bolts!
- Do not use a crane to release the movable unit from concrete!

Procedure

1. Release element connections between the movable units: see Instructions for Assembly and Use for the formwork system.
2. Remove recoverable tie components. (Fig. E2.07a)
3. Take the load off the brace frame.
 - SB-A0, A, B: with Spindle Base SB-A0/A/B (1.2). (Fig. E2.07)
 - SB-2: with Adjusting Unit SB-2 (6.1). (not shown)
4. Remove any concreting platforms that have been installed.
5. Attach the movable unit (element with brace frame) to the crane and move it.
6. Clean the movable unit and move it to a new place of use.

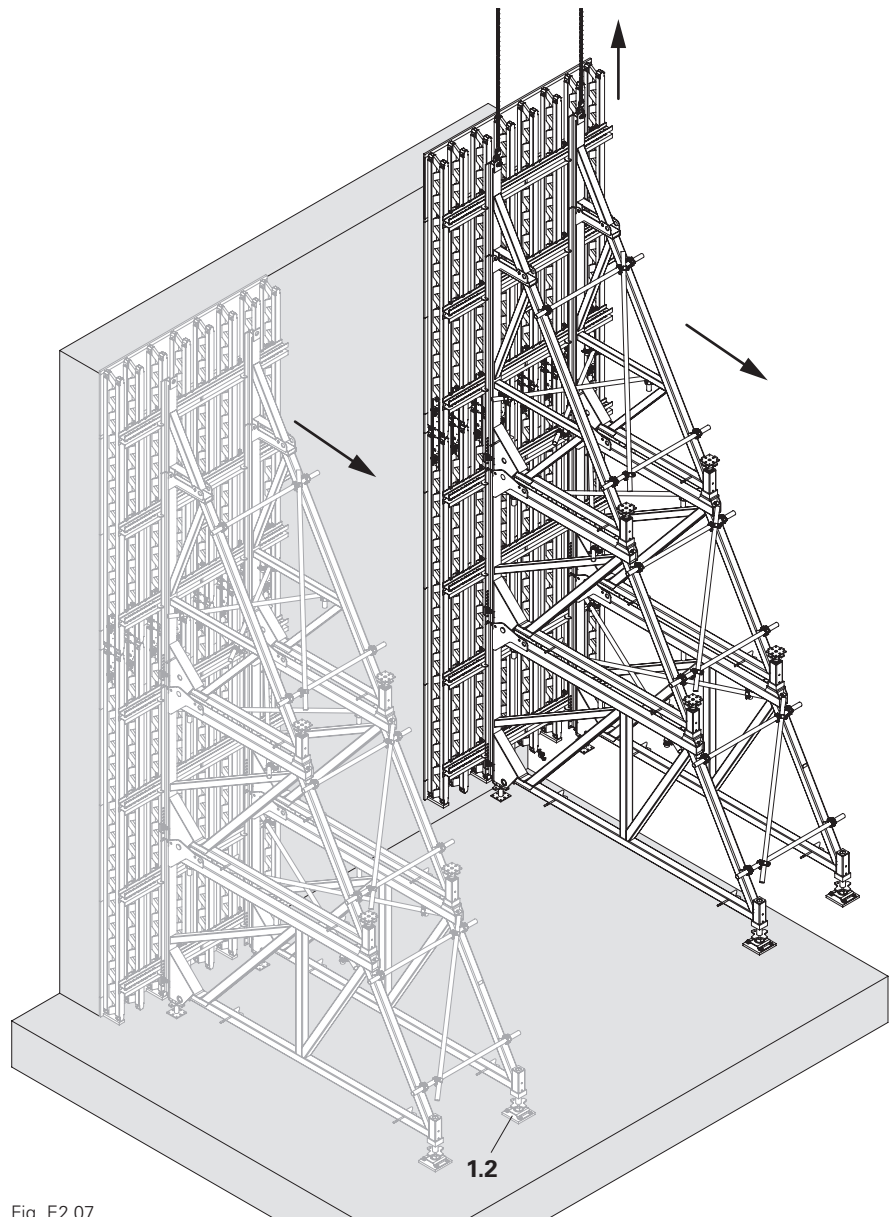

Fig. E2.07

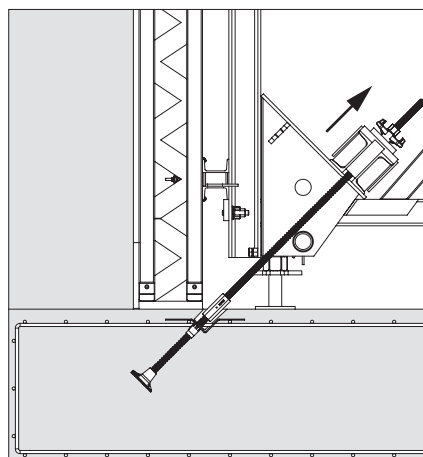

Fig. E2.07a

SB-A0, A, B, C



- Always attach movable units to the brace frame when transporting.
- Always use the available load-bearing points as well as textile straps!
- Observe the permissible load-bearing capacities!
- The fastenings/wedges must be checked each and every time before they are set aside. Where necessary, secure wedges using cotter pins or bolts!



- Secure the brace frames to prevent them from tipping over.
- Remove concreting and work platforms before starting the attachment procedure.

Dismantling

Girder and panel formwork

1. Dismantle the work platform and means of access.
2. Set the unit down on squared timbers. (Fig. E3.01)
3. Remove bracing.
4. Loosen or remove the connections (35 + 36 / 38 / 40 / 41) to the system.
5. Release the brace frames from the formwork one by one and set them down with the crane.
6. Remove the connections (35 + 36 / 38 / 40 / 41) on the brace frame or formwork. (Fig. E3.02 + Fig. E3.03)

Dismantling the brace frame

Starting at SB-C

1. Loosen the connecting bolts (1.5 + 1.6 / 3.5 + 3.6 / 4.1 + 4.2) between the brace frames and bolt them back into the upper brace frame.
2. Fit spindles (1.2 / 1.4 / 2.2 / 2.4 / 3.2 / 3.4) back into the brace frames.
3. Stack brace frames of the same size and secure with steel straps. See Section "A2 Storage and transportation" on page 20. (Fig. E3.04)

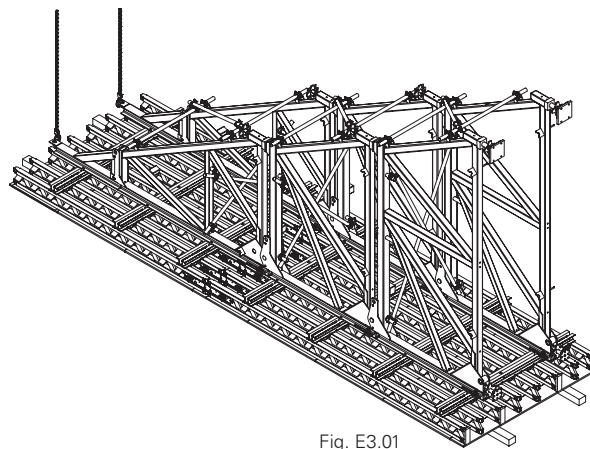

Fig. E3.01

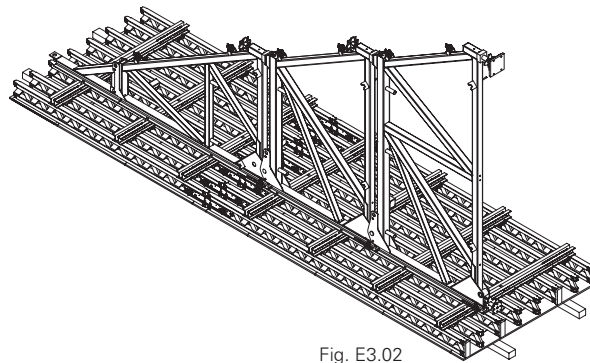
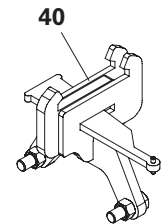
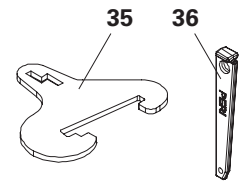

Fig. E3.02

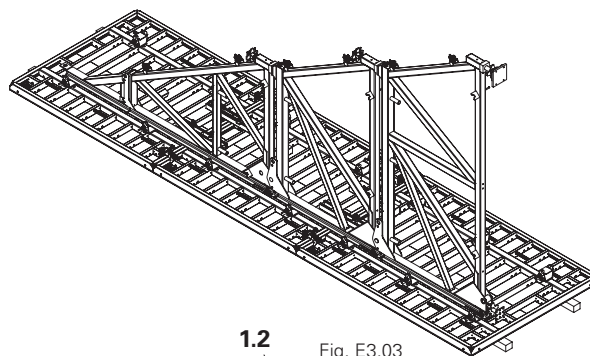
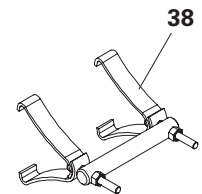

Fig. E3.03

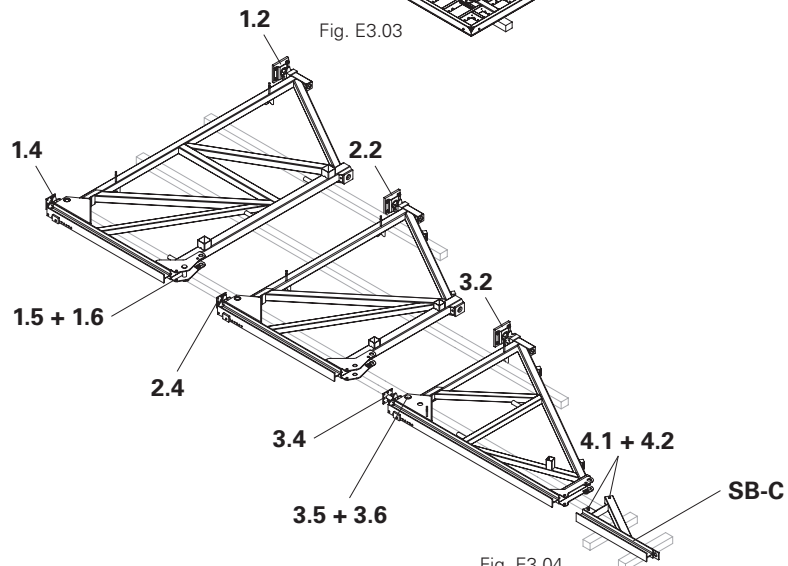
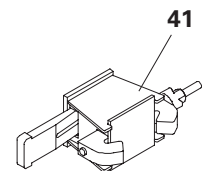

Fig. E3.04

SB-2



- Always attach movable units to the brace frame when transporting.
- Always use the available load-bearing points as well as textile straps!
- Observe the permissible load-bearing capacities!
- The fastenings/wedges must be checked each and every time before they are set aside. Where necessary, secure wedges using cotter pins or bolts!



- Secure the brace frames to prevent them from tipping over.
- Remove concreting and work platforms before starting the attachment procedure.

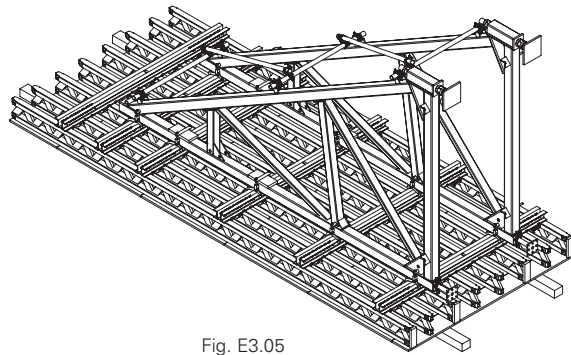

Fig. E3.05

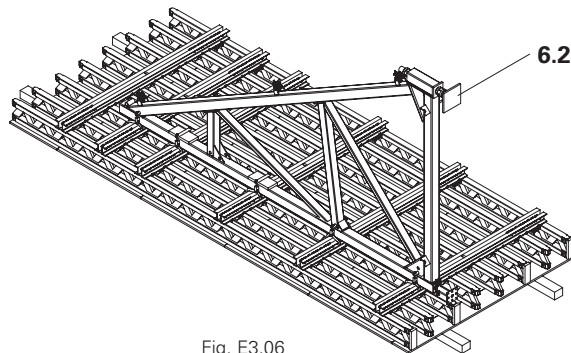
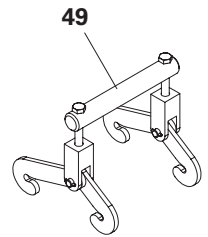

Fig. E3.06

Dismantling

Girder and panel formwork

1. Dismantle the work platform and means of access.
2. Set the unit down on squared timbers.
3. Remove bracing.
4. Loosen or remove connections to the system (49).
5. Release the brace frames from the formwork one by one and set them down with the crane. (Fig. E3.05 + Fig. E3.06)
6. Remove Connection Rail SB-2/TR,MX,D (50) from the formwork unit:
 - Loosen the wedge and remove Bolt SB and Sleeve SB. (Fig. E3.07)

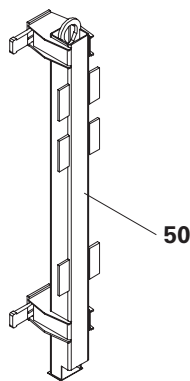

Fig. E3.07

When transporting

1. Remove adjustment unit-2 (6.2) and pack separately for return transport.
2. Stack brace frames and secure with steel straps. See Section "A2 Storage and transportation" on page 20. (Fig. E3.06)

Application



**The application is project-specific!
Consult PERI before planning single-sided inside corners!**

PERI Brace Frames SB can also be used as heavy-duty console brackets. This application makes it possible to have larger work platforms ($b \leq 8.17 \text{ m} + \text{cantilever}$) while at the same time absorbing high shear forces. This form of use is always specific to the project at hand.

There are two variants:

- Single suspension
- Double suspension

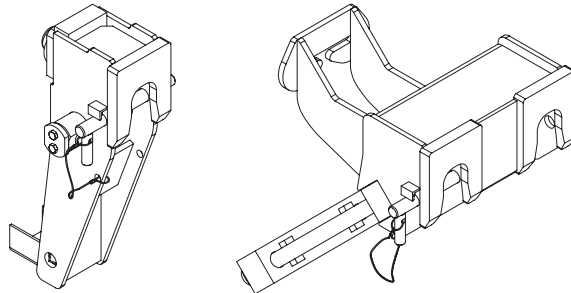

- **Horizontal use should always be planned separately, facilitated by a project-related structural calculation!**
- **Structural verification should always be provided for the (horizontal) brace frame!**
- **Separate structural verification is required for the introduction of forces into the concrete and their absorption by the structural component!**
- **Required concrete strengths, edge distances and wall thicknesses according to structural requirements!**



The contractor commissioned to install the anchoring or their representative is responsible for carrying out installation correctly in accordance with the intended use. They shall also arrange for the delivery and correct installation of any additional reinforcement required.

A record must be kept of the verification of the actual concrete strength, the inspection of single components, proper assembly and the anchoring depth. If different installation lengths of a cone type are used on a construction site, each anchoring point must be checked before concreting takes place. Proof must be provided that all load transfers in the building are distributed into the ground. Divergent conditions necessitate separate structural verification in accordance with the applicable regulations.

Fitting the leading tie

Preparation

Measure the position of the leading tie on the ground plan and in terms of height and mark it on the formwork surface.

Standard: M36 screw



- Ensure there is sufficient distance to the formwork girder. (Fig. F2.01a)
- If the distance is insufficient, the anchor positioning stud must be used.
- Check all tie components, assembly and position before concreting takes place.
- Before deshuttering the formwork, always loosen the positioning screws first!
- The sealing required for removing the climbing cones must be determined in advance.

Components per climbing tie

25 Tie Rod DW26	1x
27 Threaded Anchor Plate DW26	1x
64 Climbing Cone-2 DW26 M36 ga	1x
69 Anchor Posit. Plate M36 ga	1x
70 Screw ISO 4017-M36x070-8.8-ga	1x
71 Hex wood screw 6x20 DIN 571	4x

Assembly

1. Drill a suitable hole in the formlining. (M30 = bore Ø 32 mm)
2. Attach Anchor Posit. Plate M36 ga (**69**) to the rear side of the formlining in line with the hole using 4x Hex-Wood-Screw 6x20 DIN 571-ga (**71**).
3. Insert the Screw ISO 4017-M36x070-8.8-ga (**70**) through the hole from the rear side.
4. Screw the Climbing Cone-2 DW26 M36 ga (**64**) onto the Screw ISO 4017-M36x070-8.8-ga (**70**) from the front side.
5. Screw Tie Rod DW26 (**25**) onto the Climbing Cone-2 DW26 M36 (**64**).
6. Screw Threaded Anchor Plate DW26 (**27**) onto Tie Rod DW26 (**25**). (Fig. F2.01 + Fig. F2.01a)



Danger

If the anchoring is installed incorrectly, the platform may collapse! Collapsing platforms can cause serious injuries or even death.

- ⇒ Loosening or removing the anchoring must only be possible from the load transfer side.
- ⇒ Do not install two cones against each other. (Fig. F2.01b)
- ⇒ The anchoring depth must not be corrected by reducing the screw-in depth.
- ⇒ Make sure there are suitable windows in the reinforcement for closing the formwork. Do not unscrew the threaded anchor plate!
- ⇒ Check all anchoring points for correct screw-in depth and integrity before concreting begins.

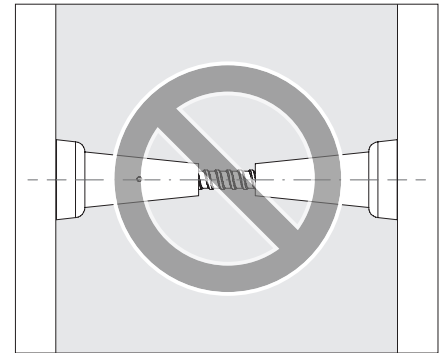

Fig. F2.01b



Precise alignment of the anchoring points in all 3 axes is essential if the climbing unit is to function correctly.

- Measure the anchoring points precisely (plumb line, chalk line) and fit them securely in their positions.
- To secure the position, fasten the Threaded Anchor Plate DW26 (**27**) to the reinforcement, for example with wire.
- To this end, tie in additional reinforcement bars both vertically and horizontally, if necessary.



To ensure that the climbing cone can be recovered later, carefully grease the surfaces that are in contact with the concrete and the internal thread for the tie rod. Seal the joint between the tie rod and the thread of the climbing cone with a sealing compound, e.g. grease.

Lateral view

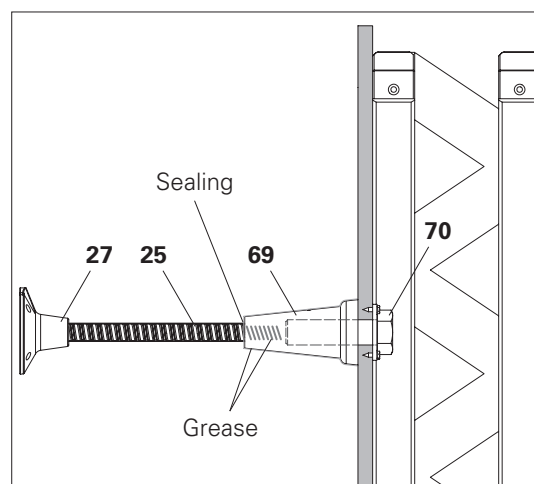

Fig. F2.01

Front view

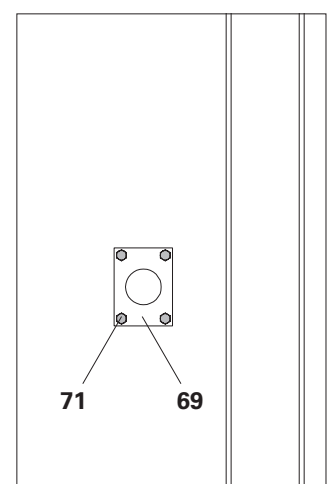

Fig. F2.01a

Alternatively: Anchor positioning stud



Caution

Possibility of getting caught on protruding nails!

Risk of injury!

⇒ Cover protruding nails, but do not bend them.



- Fix the Threaded Anchor Plate DW 26 (27) to the reinforcement with wire to secure the position. If necessary, close the formwork from the other side.
- Check all tie parts, the assembly and positioning before concreting, especially if the anchoring depth of the anchoring points is significant.
- If possible, use the fixing with the positioning screw as the connection is more stable.
- When deshuttering the formwork, the nails must be pulled through the formlining. So, do not bend the nails.
- To ensure that the climbing cone can be recovered later, carefully grease the surfaces that are in contact with the concrete and the internal thread for the tie rod. Seal the joint between the tie rod and the thread of the climbing cone with a sealing compound, e.g. grease.

Components per climbing tie

25	Tie Rod DW26	1x
27	Threaded Anchor Plate DW26	1x
64	Climbing Cone-2 DW26 M36 ga	1x
72	Anchor Posit. Stud M36 ga	1x
73	Wire nail 3.0x80 mm	6x

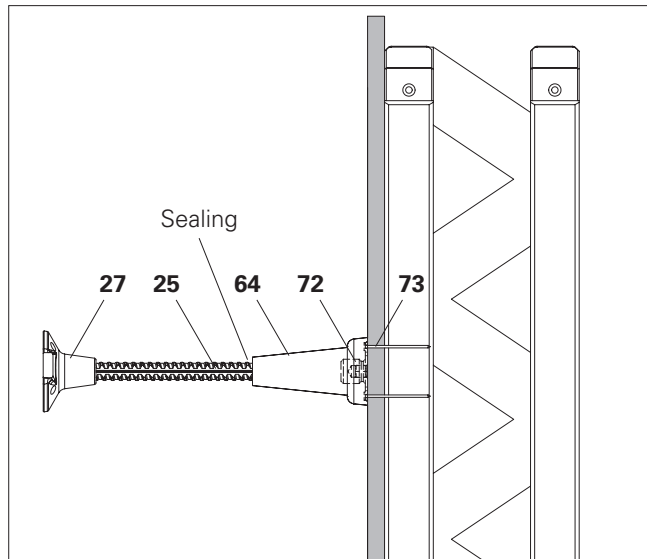

Fig. F2.02

Possible suspensions for brace frame combinations

Brace Frame	Single suspension	Double suspension
	Suspension Shoe SB (106661)	Suspension Shoe SB double (111866)
SB A0 + A + B + C	X	X
SB A0 + A + B	X	X
SB A + B + C	X	X
SB A + B	X	X
SB B + C	X	X
SB B	X	X
SB-2	X	

Tab. F2.01

Assembly

1. Nail the Anchor Posit. Stud M36 (72) to the front side of the formlining using 6x wire nails 3.0x80 mm (73).
2. Screw Climbing Cone-2 DW26 M36 ga (64) onto the Anchor Posit. Stud M36 ga (72).
3. Screw Tie Rod DW26 (25) onto the Climbing Cone-2 DW26 M36 (64).
4. Screw Threaded Anchor Plate DW26 (27) onto Tie Rod DW26 (25). (Fig. F2.02)

Single suspension with Suspension Shoe SB

Brace Frame SB-A0, A, B, C

Suspension shoe load combinations are project-specific.

Required components for each brace frame:

62	Suspension Shoe SB	1x
63	Brace Frame Adaptor SB-A0,A,B	1x
	Tie point	
25	Tie Rod DW26	1x
27	Threaded Anchor Plate DW26	1x
64	Climbing Cone-2 DW26 M36 ga	1x
65	Scaff. Mount. Ring M36 galv	1x
66	Screw ISO 4014-M36x130-10.9	1x

Assembly

1. Pre-assemble brace frames and remove front spindle, see B1.
2. Loosen both nuts (**63.1**) on the Brace Frame Adaptor SB-A0,A,B (**63**), AF 36.
3. Push the brace frame adaptor through the hole in the brace frame.
4. Place Suspension Shoe SB (**62**) on the brace frame, insert bolts through the right and left holes as well as through the holes in the brace frame adaptor.
5. Secure the Suspension Shoe SB (**62**) to the brace frame with bolts. (Fig. F2.04)

Creating a work platform

- Create a work platform according to the plan.
- Brace the work platform with diagonals and make open building edges secure.
- Ensure stability.

Mounting the work platform

1. Gently loosen the Climbing Cones-2 DW26 M36 ga (**64**) that are set in concrete and tighten them again, AF 55.
2. Screw the Scaff. Mount. Ring M36 galv (**65**) into the Climbing Cones-2 DW26 M36 ga (**64**) using screws ISO 4014-M36x130-10.9 (**66**).

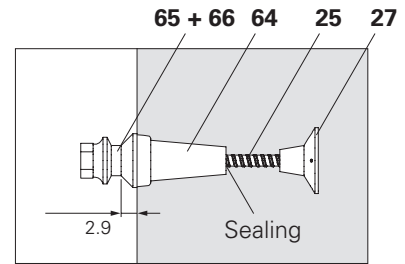
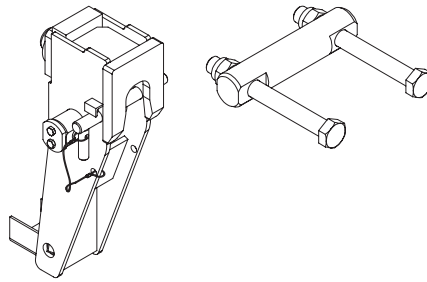

Fig. F2.03

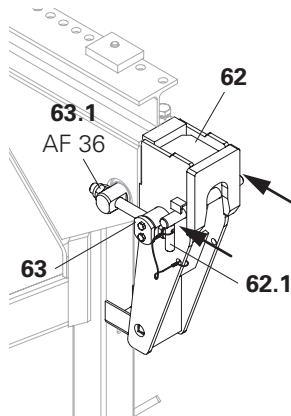

Fig. F2.04

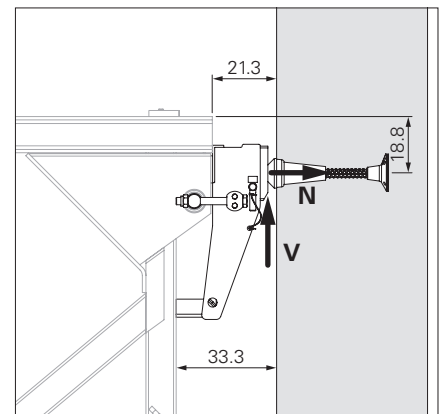

Fig. F2.05

3. Remove bolts (**62.1**) from the suspension shoes.
4. Attach the work platform to the crane (textile strap) and move it.
5. Attach the work platform to the mounting rings using the suspension shoes and secure with bolts. (Fig. F2.05 + Fig. F2.06)



Have all suspension shoes been mounted and secured?

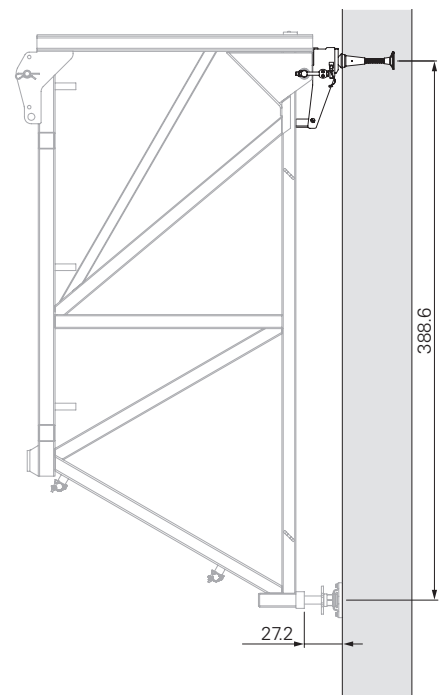

Fig. F2.06

F2 Use as horizontal heavy-duty console bracket



The platform cantilever calculations must be carried out on a project-specific basis.

Combination SB-A0, A, B, C

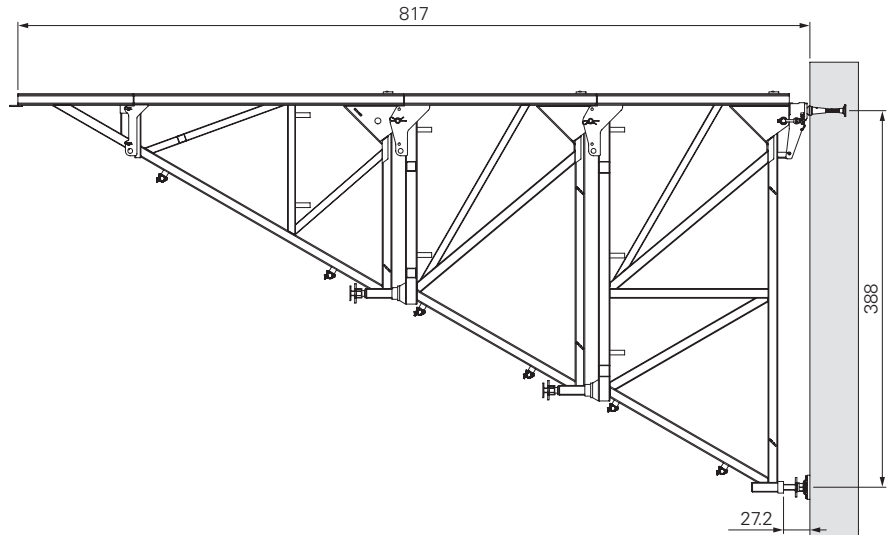

Combination SB-A0, A, B

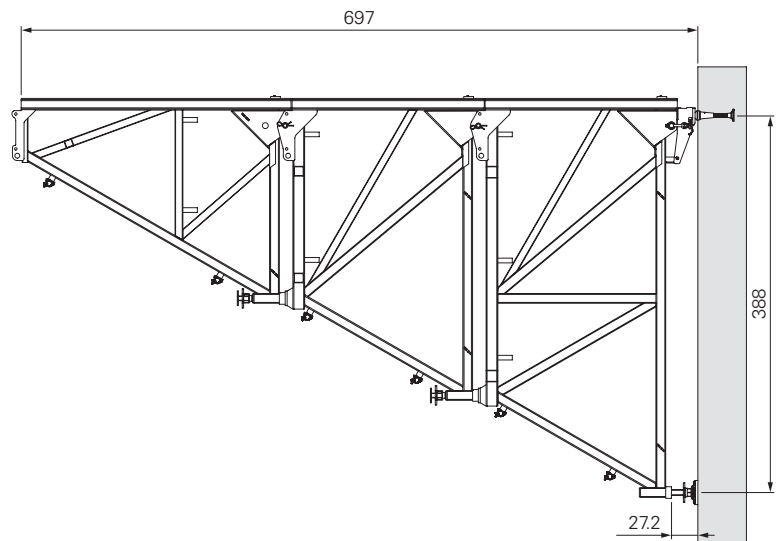

Combination SB-A, B, C

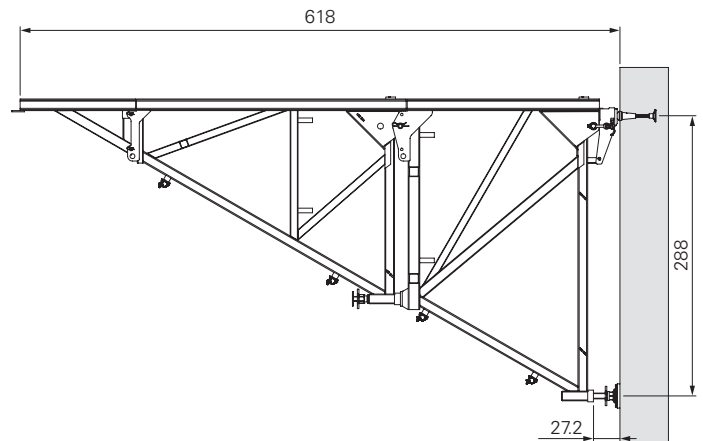

F2 Use as horizontal heavy-duty console bracket



The platform cantilever calculations must be carried out on a project-specific basis.

Combination SB-A, B

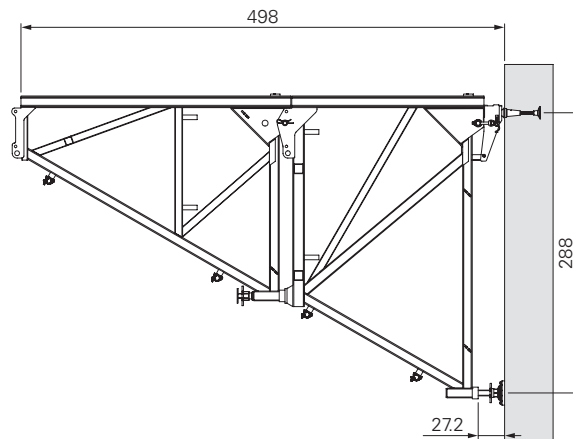

Combination SB-B, C

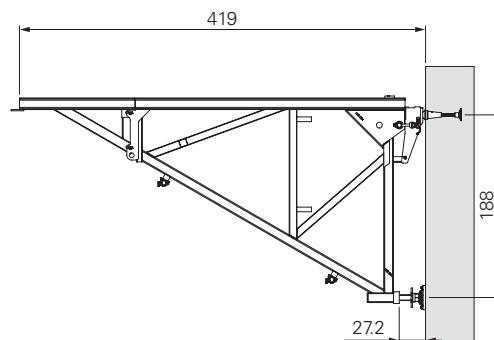

Combination SB-B

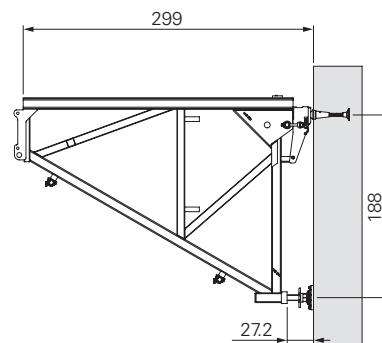

Brace Frame SB-2

Work platform $b \leq 4.80$ m

Suspension shoe load combinations are project-specific.

Required components for each brace frame:

62	Suspension Shoe SB	1x
67	Brace Frame Adaptor SB-2	1x
	Tie point	
25	Tie Rod DW26	1x
27	Threaded Anchor Plate DW26	1x
64	Climbing Cone-2 DW26 M36 ga	1x
65	Scaff. Mount. Ring M36 galv	1x
66	Screw ISO 4014-M36x130-10.9	1x

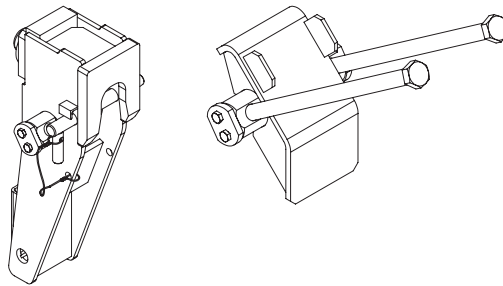

Assembly

1. Pre-assemble brace frames and remove front spindle, see B1.
2. Loosen both nuts (**67.1**) on the Brace Frame Adaptor SB-2 (**67**), AF 36.
3. Place the brace frame adaptor on the brace frame.
4. Place Suspension Shoe SB (**62**) on the brace frame, insert bolts through the right and left holes as well as through the holes in the brace frame adaptor.
5. Secure the suspension shoe on the brace frame with screws and nuts. (Fig. F2.07 + Fig. F2.08)

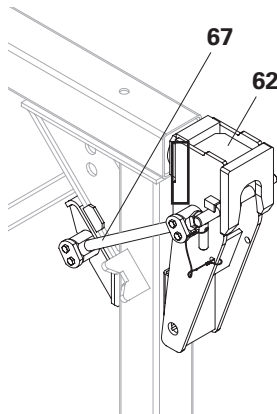

Fig. F2.07

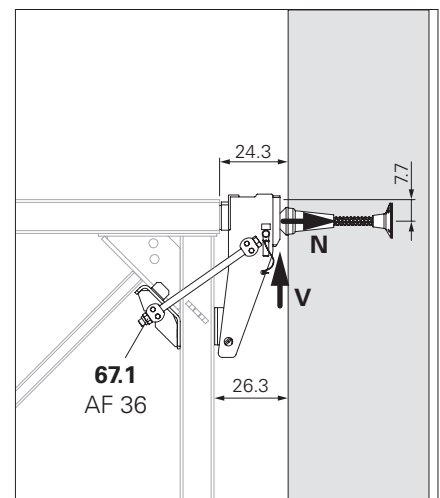

Fig. F2.08

Creating a work platform

- Create a work platform according to the plan.
- Brace the work platform with diagonals and make open building edges secure.
- Ensure stability.

Mounting the work platform

(Fig. F2.08)

To fit Brace Frame SB-2, See Section "Single suspension with Suspension Shoe SB" on page 78.

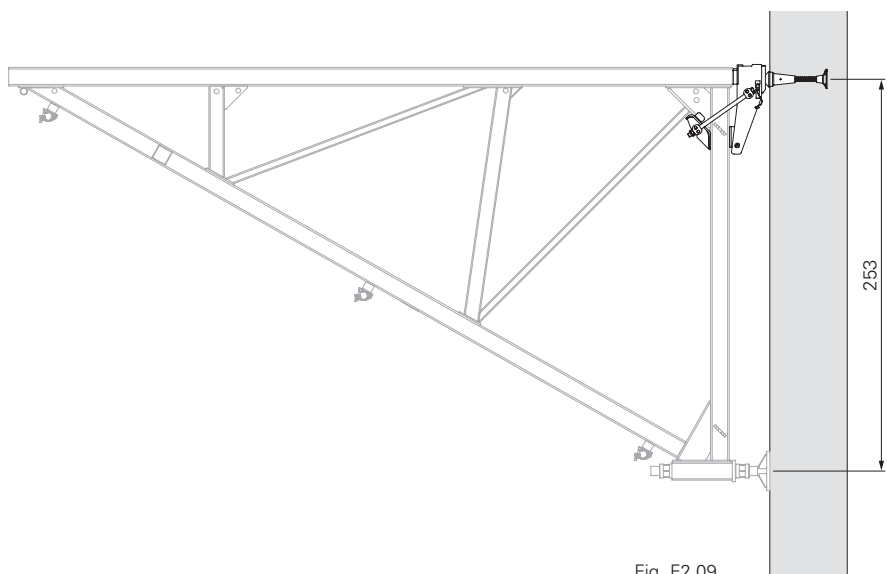

Fig. F2.09

Double suspension with Suspension Shoe SB double

Brace Frame SB-A0, A, B, C

Suspension shoe load combinations are project-specific.

Required components for each brace frame:

68 Suspension Shoe SB double	1x
Tie point	
25 Tie Rod DW26	2x
27 Threaded Anchor Plate DW26	2x
64 Climbing Cone-2 M36/DW 26	2x
65 Scaff. Mount. Ring M36 galv	2x
66 Bolt ISO 4014 M36 x 130-10.9	2x

Assembly

1. Pre-assemble brace frames and remove front spindle, see B1.
2. Loosen the nuts (**68.2**) on the threaded rods (**68.1**), AF 46 and remove the counterholder (**68.3**).
3. Push the Suspension Shoe SB double (**68**) onto the HEB Beam as far as it will go.
4. Slide the counterholder onto the threaded rods and clamp it to the brace frame with nuts.

(Fig. F2.10 + Fig. F2.11)

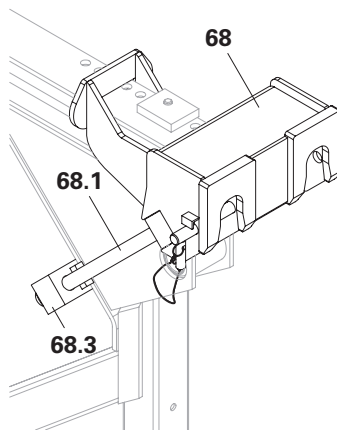
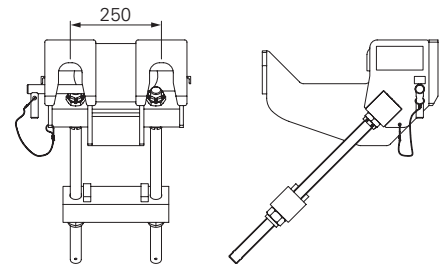
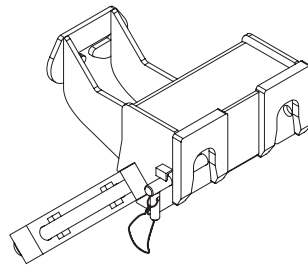

Fig. F2.10

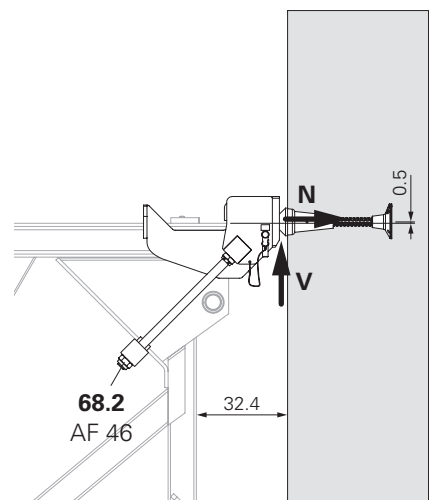

Fig. F2.11

Creating a work platform

- Create a work platform according to the plan.
- Brace the work platform with diagonals and make open building edges secure.
- Ensure stability.

Mounting the work platform

(Fig. F2.11)

See single suspension for Brace Frame SB-A0, A, B.

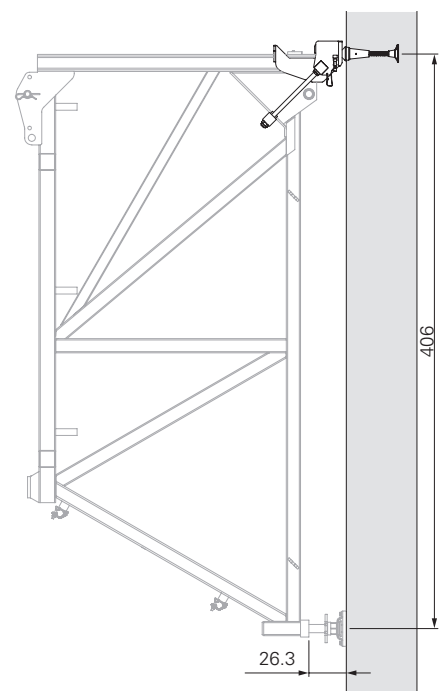

Fig. F2.12

F2 Use as horizontal heavy-duty console bracket



The platform cantilever calculations must be carried out on a project-specific basis.

Combination SB-A0, A, B, C

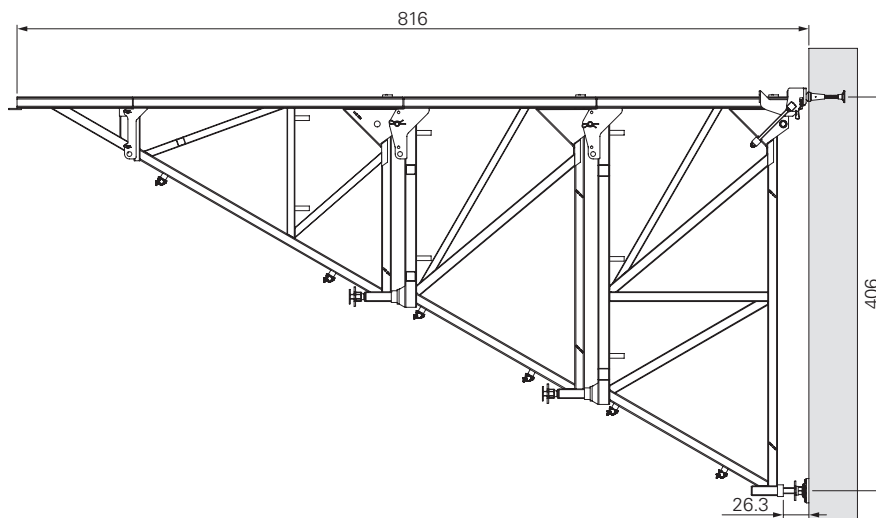

Combination SB-A0, A, B

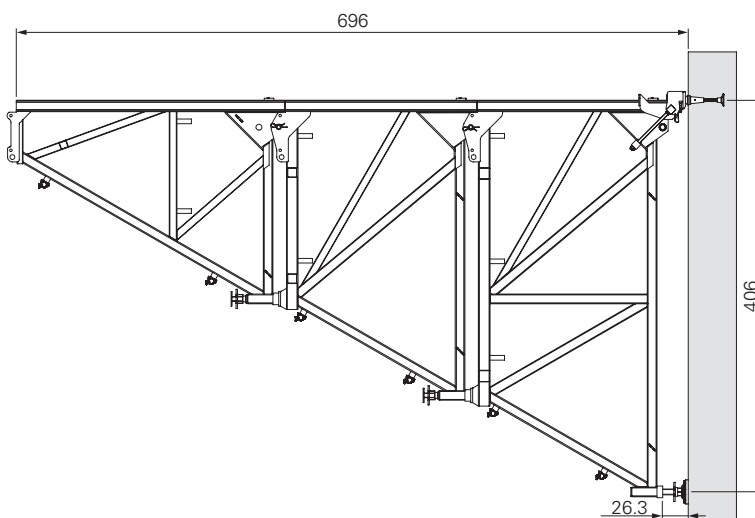

Combination SB-A, B, C

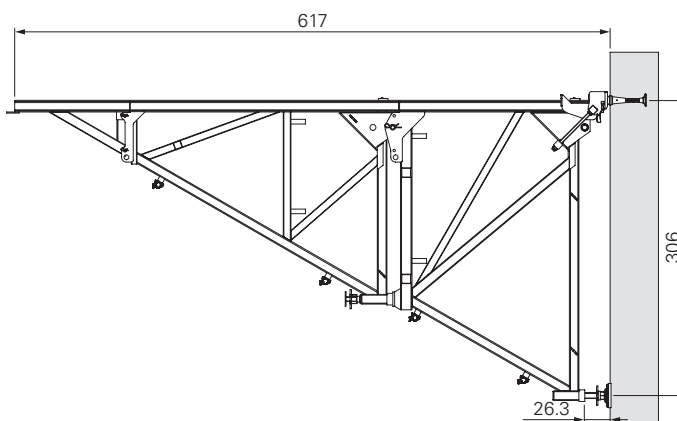

F2 Use as horizontal heavy-duty console bracket



The platform cantilever calculations must be carried out on a project-specific basis.

Combination SB-A, B

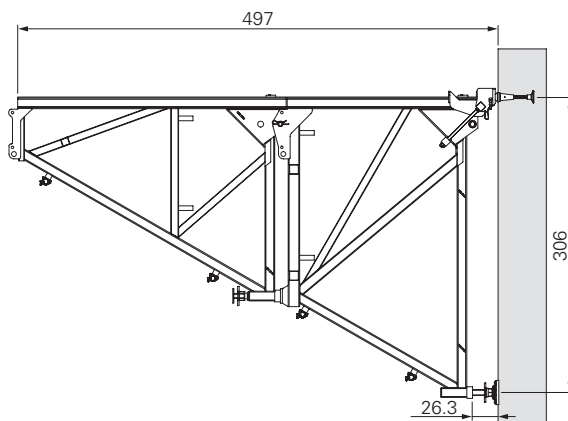

Combination SB-B, C

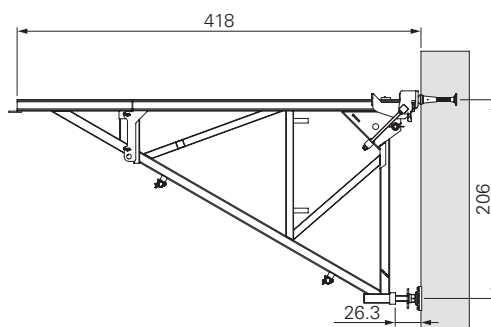

Combination SB-B

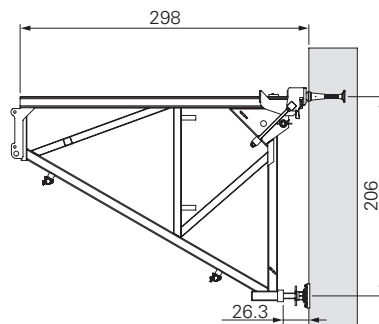

System Components SB

Art no. Weight [kg]

025690 412.000 **Brace Frame SB-A0**

For forming single-sided walls and special applications.

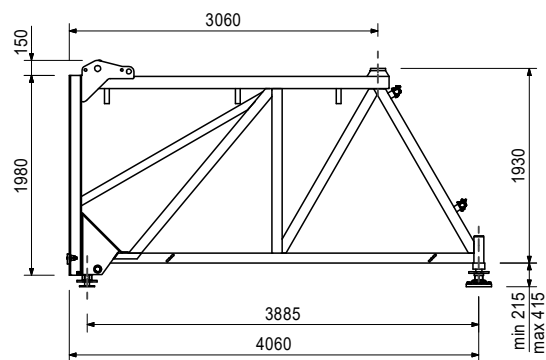
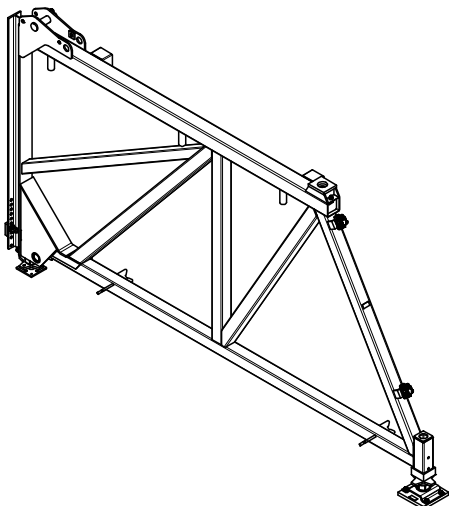

Accessory (not included)

027210 3.300 **Open-End Wrench SW80 for SB**

Consists of

- 1 pc 700555 Spindle Base SB-A0,A,B
- 1 pc 700554 Adjust. Nut SB-A0,A,B
- 1 pc 025730 Spindle TR60x9/43
- 1 pc 710545 Pin Ø50x150mm coat
- 1 pc 710618 Cotter Pin 8/1 coat
- 2 pc 131404 ScrewOon Cou.-2 HT BØ48mm M20
- 1 pc 700553 Formwork Lifter SB-A0,A,B
- 1 pc 030130 Cam Nut DW15 coat

System Components SB

Art no. Weight [kg]

025700 325.000 **Brace Frame SB-A**

For forming single-sided walls and special applications.

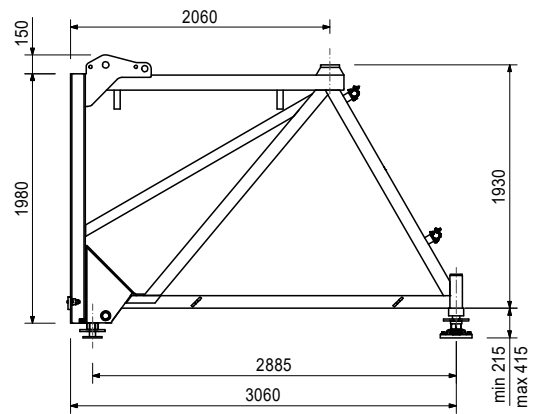
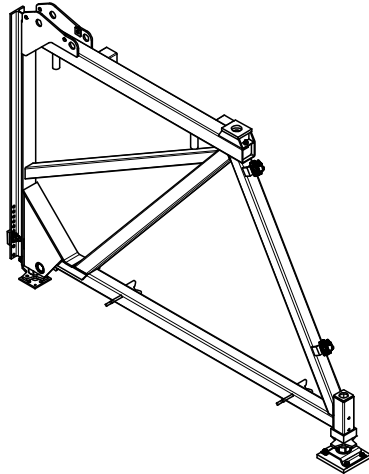

Accessory (not included)

027210 3.300 **Open-End Wrench SW80 for SB**

Consists of

- 1 pc 700555 Spindle Base SB-A0,A,B
- 1 pc 700554 Adjust. Nut SB-A0,A,B
- 1 pc 025730 Spindle TR60x9/43
- 2 pc 131404 Screw-On Cou.-2 HT B Ø48mm M20
- 1 pc 700553 Formwork Lifter SB-A0,A,B
- 1 pc 030130 Cam Nut DW15 coat

System Components SB

Art no. Weight [kg]

025710 276.000 **Brace Frame SB-B**

For forming single-sided walls and special applications.

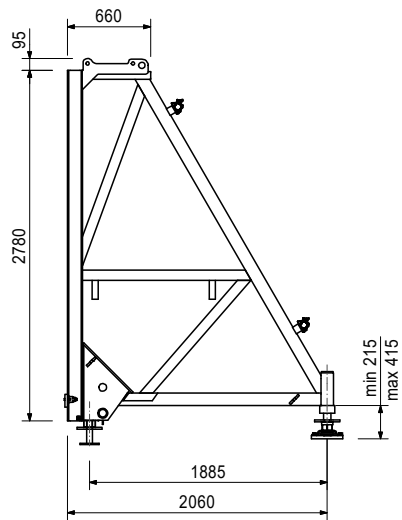
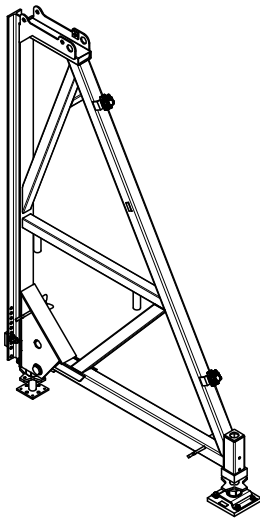

Accessory (not included)

027210 3.300 **Open-End Wrench SW80 for SB**

Consists of

- 1 pc 700555 Spindle Base SB-A0,A,B
- 1 pc 700554 Adjust. Nut SB-A0,A,B
- 1 pc 025730 Spindle TR60x9/43
- 1 pc 710545 Pin Ø50x150mm coat
- 1 pc 710618 Cotter Pin 8/1 coat
- 2 pc 131404 Screw-On Cou.-2 HT BØ48mm M20
- 1 pc 700553 Formwork Lifter SB-A0,A,B
- 1 pc 030130 Cam Nut DW15 coat

Art no. Weight [kg]

025720 49.900 **Brace Frame SB-C**

For forming single-sided walls and special applications.

Notes

Permissible load-bearing point capacity 1.5t with crane sling angle $\leq 15^\circ$, 2.5t with vertical lift.

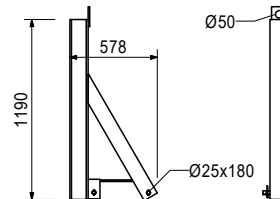
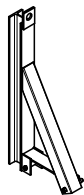

Consists of

- 2 pc 715936 Pin with Clamping Sleeve
- 2 pc 018060 Cotter Pin 4/1 ga

System Components SB - VARIOKIT

Art no. Weight [kg]

027510	365.000	Brace Frame SB-2
--------	---------	-------------------------

For forming single-sided walls and special applications.

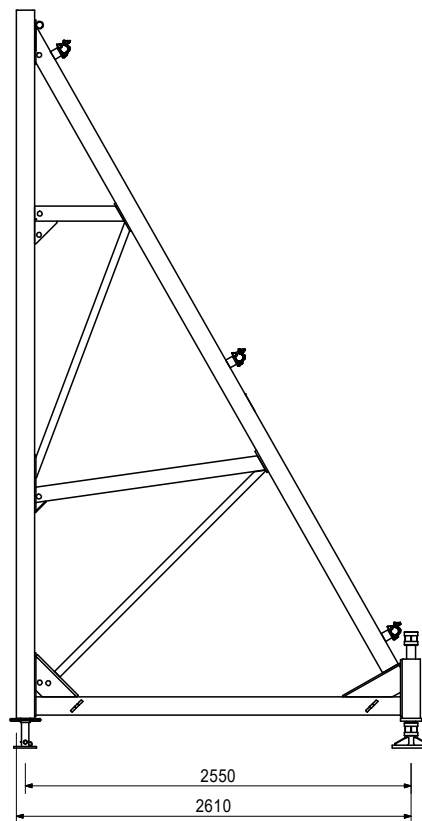
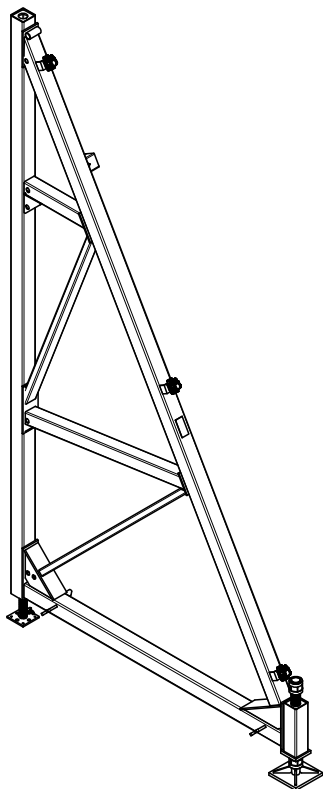

Accessory (not included)

027210	3.300	Open-End Wrench SW80 for SB
--------	-------	------------------------------------

Consists of

- 1 pc 715121 Adjusting Unit SB2
- 1 pc 715110 Spindle SB1 cpl
- 1 pc 770012 Sleeve ISO8752-08.0x060-coat
- 3 pc 131404 Screw-On Cou.-2 HT BØ48mm M20

Art no. Weight [kg]

025750	28.700	Guide Roller SB-A0,A,B
--------	--------	-------------------------------

For moving SB-A0, SB-A and SB-B brace frame units.

Notes

Permissible load capacity 1.2t.

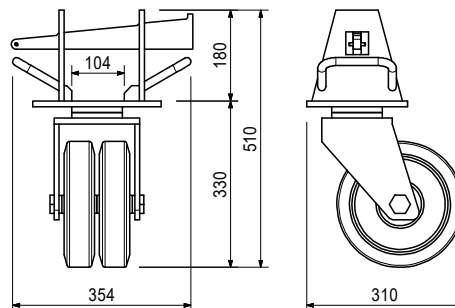
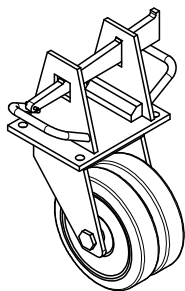

System Components SB - VARIOKIT

Art no. Weight [kg]

118584	112.000	Strongback SCS 325
--------	---------	---------------------------

Strongback with Spindle Connector SCS to support the formwork.

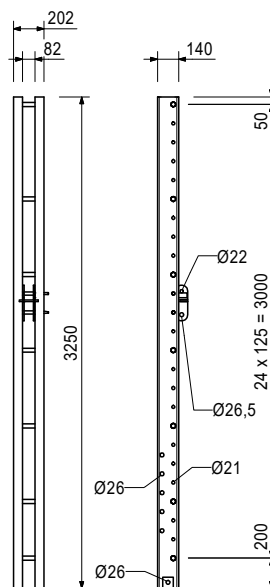

Accessory (not included)

051030	5.530	Height Adjusting Unit CB SCS
110059	2.840	Waler Fixation U100/U120

Consists of

1 pc 118580 Spindle Connector SCS Ø26/21mm

Art no. Weight [kg]

118799	51.700	Starter Bar SCS
--------	--------	------------------------

Basic bar for the erection of a brace frame for the starter.

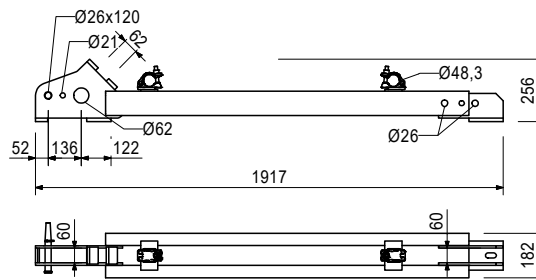
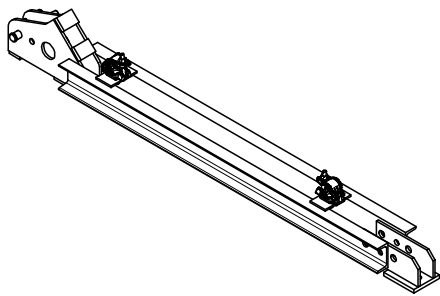

Consists of

- 2 pc 017040 Screw-On Coupler DK 48 ga
- 1 pc 022230 Cotter Pin 5/1 ga
- 1 pc 111567 Fitting Pin Ø26x120mm

System Components SB - VARIOKIT

Art no. Weight [kg]

118585 46.300 **Heavy Duty Spindle SCS 198-250**

Adjustable diagonal strut to support the strongback.

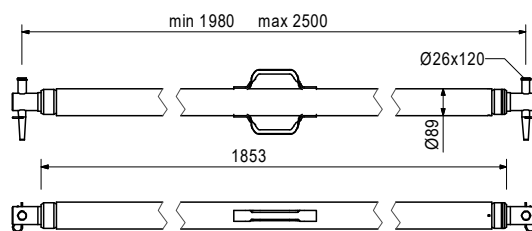
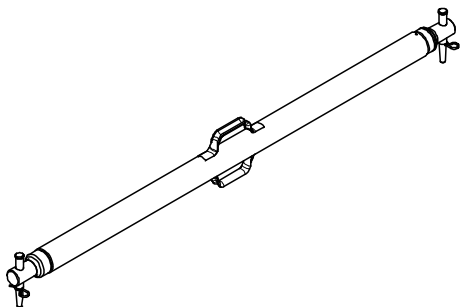

Consists of

2 pc 111567 Fitting Pin Ø26x120mm

2 pc 022230 Cotter Pin 5/1 ga

Art no. Weight [kg]

118580 5.500 **Spindle Connector SCS Ø26/21mm**

Spare part for Strongback SCS.

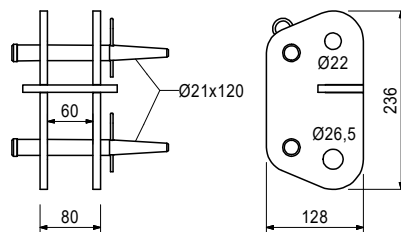
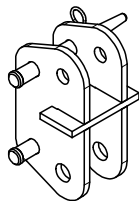

Consists of

2 pc 104031 Fitting Pin Ø21x120mm

2 pc 018060 Cotter Pin 4/1 ga

System Components SB - VARIOKIT

Art no.	Weight [kg]		L [mm]
Steel Walers SRU U120			
103874	30.900	Steel Waler SRU 122 U120	1222
103892	65.600	Steel Waler SRU 247 U120	2472

Universal steel waler profiles with profile U120 used as waling for girder wall formwork and for diverse special applications. With adjustable spacers.

Notes

Permissible load: see PERI Design Tables.
 SRU 120 $W_y=121.4\text{cm}^3$, $I_y=728\text{cm}^4$.
 SRU 140 $W_y=172,8\text{cm}^3$, $I_y=1210\text{cm}^4$.

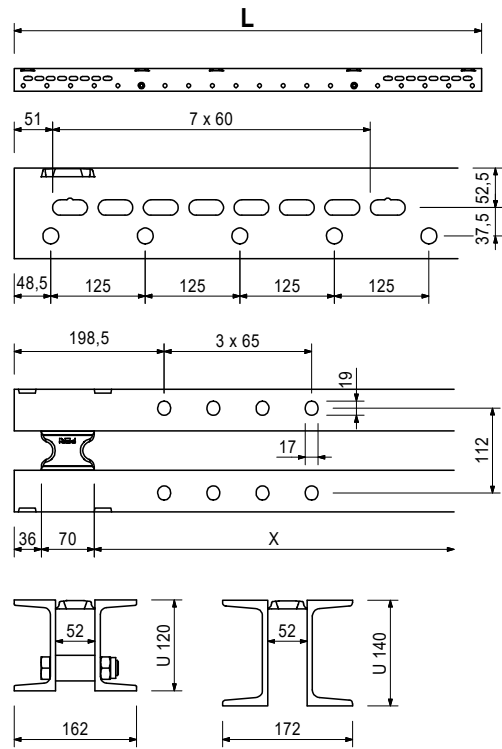
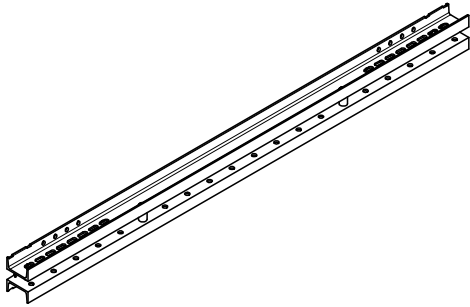

Art no.	Weight [kg]	
115623	5.040	Corner Connector VARIOKIT SRU

For a rigid connection of Steel Walers SRU.

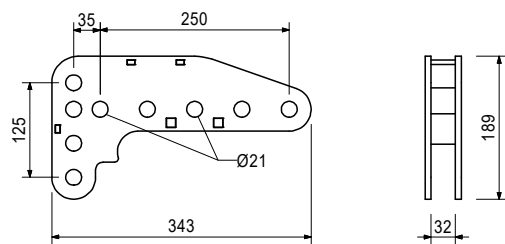
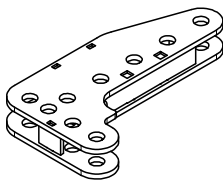

Accessory (not included)

104031	0.462	Fitting Pin Ø21x120mm
018060	0.014	Cotter Pin 4/1 ga

Accessories SB

Art no. Weight [kg]

027520 7.030 **Double Anchor Tie Yoke DSW**

For anchoring with Tie Rod DW15.

Notes

Permissible load 2x90kN.

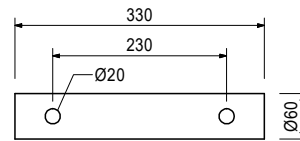
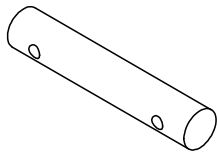

Art no. Weight [kg]

027650 9.820 **Anchor Waler 55 U140**

For anchoring of Brace Frame SB.

Notes

Permissible load 2x135kN.

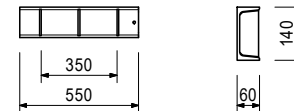
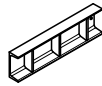

Art no. Weight [kg]

109017 11.600 **Anchor Walet 55 U160**

For anchoring of Brace Frame SB.

Notes

Permissible load 2x250kN.

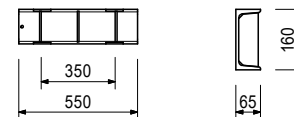
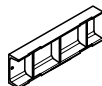

Art no. Weight [kg]

027530 39.800 **Anchor Waler 235 U140**

For anchoring of Brace Frame SB.

Notes

Permissible load 4x135kN.

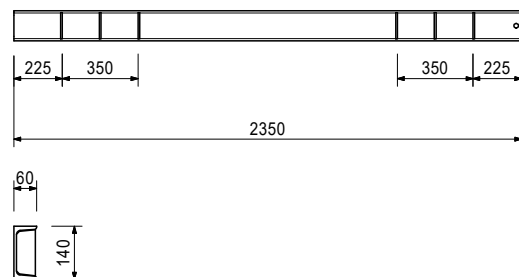
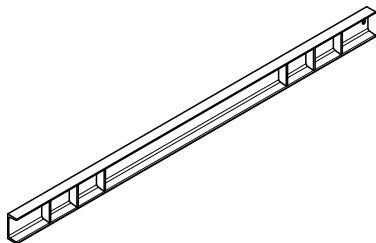

Accessories SB

Art no. Weight [kg]

030830 2.180 **Counterplate DW20 120x120x20mm**

For anchoring with Tie Rod DW20 and B20.

Notes

Permissible load 150kN.

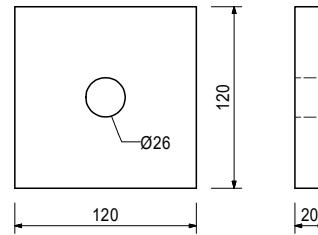
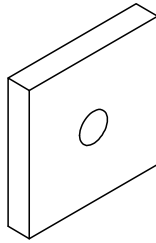

Art no. Weight [kg]

030420 2.140 **Counterplate DW26 120x120x20mm**

For anchoring with Tie Rod DW26.

Notes

Permissible load 250kN.

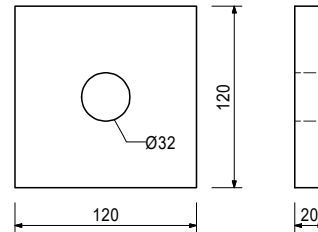
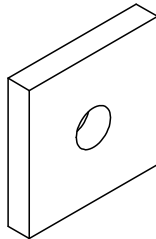

Art no. Weight [kg]

114082 2.860 **Counterplate RCS DW20**

Counterplate with centring for anchoring through the Climbing Rail RCS.

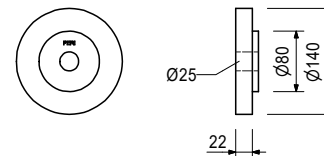

Art no. Weight [kg]

027480 7.960 **Anchor Plate SB DW26**

For anchoring of Brace Frame SB.

Notes

Permissible load 250kN.

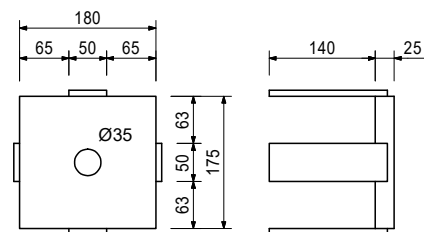
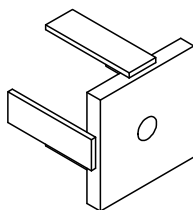

Accessories SB

Art no. Weight [kg]

101621	10.100	Anchor Rele. Plate SB DW26 cpl
--------	--------	---------------------------------------

For anchoring of Brace Frame SB. Allows easy release of higher tensile loads. In connection with Anchor Waler 55 or 235. Turn bolt to working position before shuttering.

Notes

Permissible load 250kN.

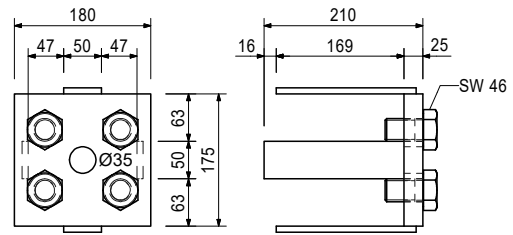
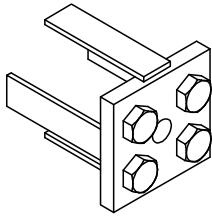

Consists of

4 pc 724563 Screw ISO4017-M30x050-8.8-ga

Art no. Weight [kg]

106661	31.800	Brace Frame Wall Scaff. Hinge
--------	--------	--------------------------------------

For horizontal use of PERI Brace Frames SB-A0,A,B and SB-2 as climbing brackets.

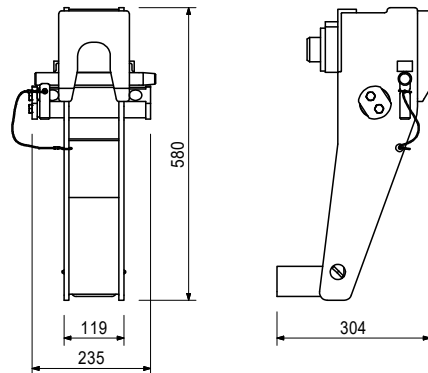
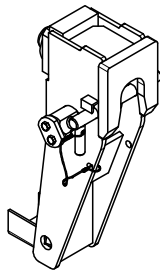

Accessory (not included)

106662	4.870	Brace Frame Adaptor SB-A0,A,B
106663	13.800	Brace Frame Adaptor SB-2

Accessories SB

Art no. Weight [kg]

111866 64.600 **Suspension Shoe SB double**

For horizontal use of PERI Brace Frames SB-A0,A,B as climbing bracket.

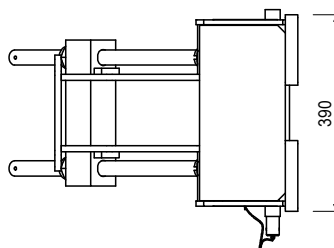
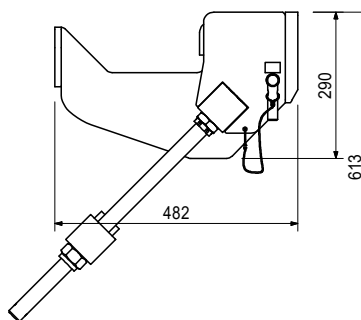
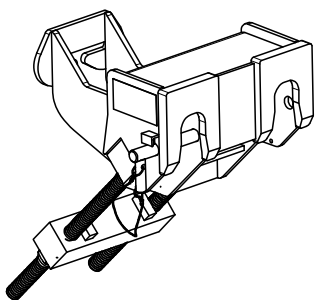

Art no. Weight [kg]

106663 13.800 **Brace Frame Adaptor SB-2**

For mounting of Brace Frame Wall Scaffold Hinge to the Brace Frame SB-2.

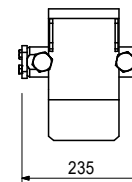
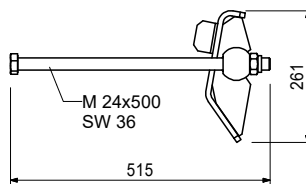
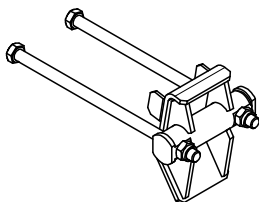

Consists of

- 2 pc 106798 Screw ISO4014-M24x500-10.9
- 2 pc 106803 Hex-Nut ISO7040-M24-10-ga

Art no. Weight [kg]

106662 4.870 **Brace Frame Adaptor SB-A0,A,B**

For mounting the brace frame wall scaffold hinge to the Brace Frame SB-A0, A or B.

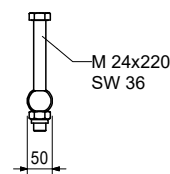
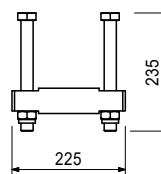
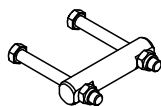

Consists of

- 2 pc 106797 Screw ISO4014-M24x220-10.9
- 2 pc 106803 Hex-Nut ISO7040-M24-10-ga

Accessories SB

Art no.	Weight [kg]	
029490	1.760	Scaff. Mount. Ring M36 galv.

Tie System M36.
For anchoring of climbing systems.

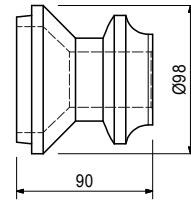
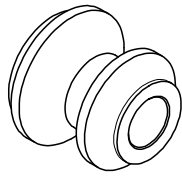

Accessory (not included)

029550	1.400	Screw ISO4014-M36x130-10.9
--------	-------	-----------------------------------

Art no.	Weight [kg]		L [mm]
029550	1.400	Screw ISO4014-M36x130-10.9	130

High-strength bolt for anchoring of climbing systems.

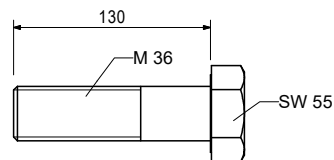
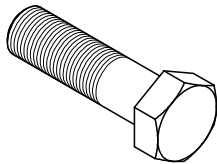

Art no.	Weight [kg]	
030940	2.980	Climbing Cone-2 DW26 M36 ga

Tie System M36. For anchoring of climbing systems.

Notes

Separate Design Information on request.

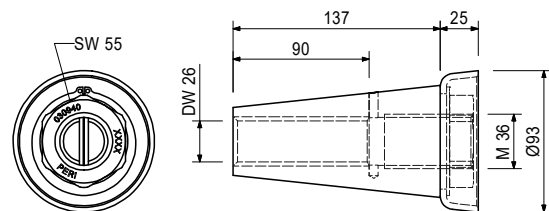
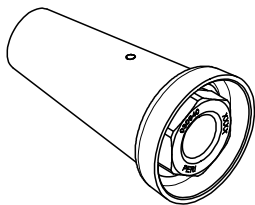

Accessory (not included)

030870	1.260	Threaded Anchor Plate DW26
030340	4.480	Tie Rod DW26 spec. Length
029430	0.930	Screw ISO4017-M36x070-8.8-ga

Art no.	Weight [kg]	
030060	2.070	Anchorage Loop DW15

Non-weldable! Take approval into consideration!

Notes

Permissible load 2x90kN.
Dependent on concrete strength and installation depth.

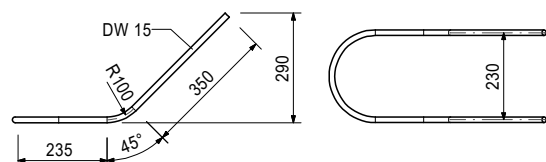

Accessories SB

Art no. Weight [kg]

Tie Rods DW 15		
030050	0.000	Cutting Cost DW15/B15
030005	0.720	Tie Rod DW15 0.5m
030010	1.230	Tie Rod DW15 0.85m
030480	1.440	Tie Rod DW15 1m
030490	1.730	Tie Rod DW15 1.2m
030170	2.160	Tie Rod DW15 1.5m
030020	2.450	Tie Rod DW15 1.7m
030180	2.880	Tie Rod DW15 2m
030710	3.600	Tie Rod DW15 2.5m
030720	4.320	Tie Rod DW15 3m
030730	5.040	Tie Rod DW15 3.5m
030160	8.640	Tie Rod DW15 6m
030030	1.440	Tie Rod DW15 spec. Length

Notes

Non-weldable! Observe the permissions! Permissible tension force 90kN.

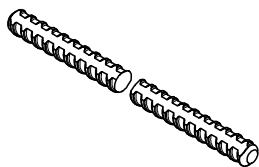

Art no. Weight [kg]

Tie Rods B15		
030050	0.000	Cutting Cost DW15/B15
030150	0.420	Tie Rod B15 L=0.30m
030740	1.550	Tie Rod B15 spec. Length

Notes

Weldable! Observe the permissions! Permissible tension force 82kN.

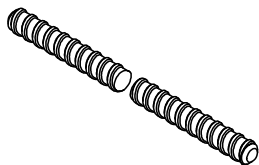

Art no. Weight [kg]

Tie Rods DW 20		
030800	0.000	Cutting Costs DW20/B20
030640	1.280	Tie Rod DW20 0.5m
030641	2.560	Tie Rod DW20 1m
030680	15.400	Tie Rod DW20 6m
030700	2.560	Tie Rod DW20 spec. Length

Notes

Weldable! Observe the permissions! Permissible tension force 150kN.

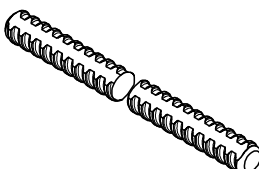

Accessories SB

Art no. Weight [kg]

Tie Tods B20

030800	0.000	Cutting Costs DW20/B20
030745	2.600	Tie Rod B20 spec. Length

Notes

Weldable! Observe the permissions! Permissible tension force 150kN.

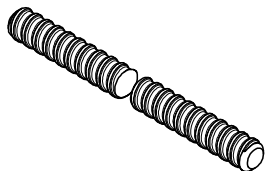

Art no. Weight [kg]

Tie Rods DW 26

030500	0.000	Cutting Costs DW26
030645	2.240	Tie Rod DW26 0.5m
030646	4.480	Tie Rod DW26 1m
030340	4.480	Tie Rod DW26 spec. Length

Notes

Non-weldable! Take official approval into consideration!
Permissible tension force 250 kN.

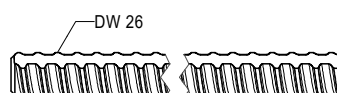
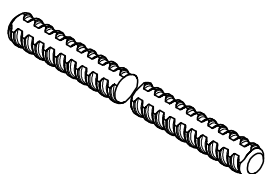

Art no. Weight [kg]

030840	0.515	Threaded Anchor Plate DW15
--------	-------	-----------------------------------

For use with Tie Rod DW15 or B15. For anchoring in concrete.

Notes

Lost anchor part.

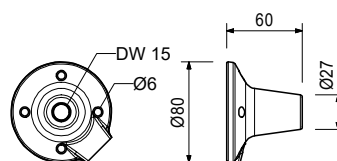
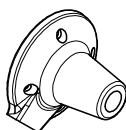

Art no. Weight [kg]

030860	0.792	Threaded Anchor Plate DW20
--------	-------	-----------------------------------

For use with Tie Rod DW20, B20 or Screw-On Cone-2 M24/DW20. For anchoring in concrete.

Notes

Lost anchor part.

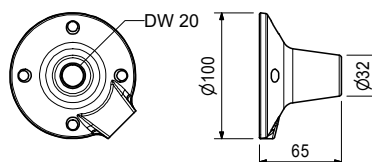
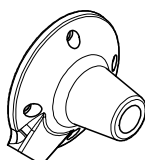

Accessories SB

Art no. Weight [kg]

030870 1.260 **Threaded Anchor Plate DW26**

For use with Tie Rod DW26 or Screw-On Cone M36/DW26. For anchoring in concrete.

Notes

Lost anchor part.

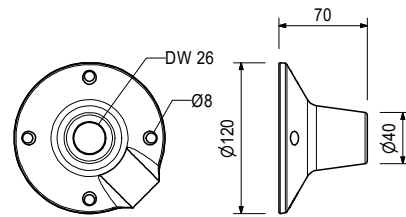
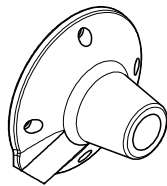

Art no. Weight [kg]

124777 0.210 **Anchor Bolt SW24 Ø14/20x130mm**

For temporary attachment to reinforced concrete components.

Notes

Take the PERI Data Sheet into consideration!
Hole Ø14mm.

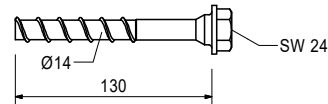
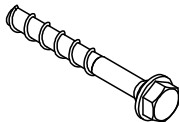

Art no. Weight [kg]

132889 0.213 **Anchor Bolt SW21 Ø14x150mm**

For temporary attachment to reinforced concrete components.

Notes

Take the PERI Data Sheet into consideration!
Hole Ø14mm.

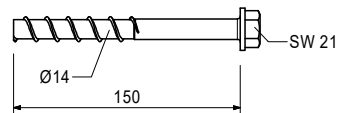
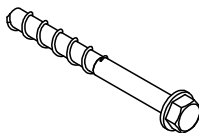

Art no. Weight [kg]

108795 0.450 **Rock Anchor HB DW15**

For subsequent anchoring with DW15 tie rods.

Notes

Follow Instructions for Use!
Permissible load 90kN.
Drill hole Ø=36,5-38mm.

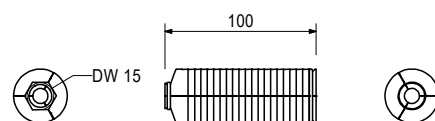
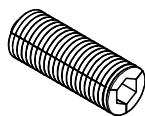

Accessories SB

Art no. Weight [kg]

030400 2.620 **Coupling Nut M30/DW26 ga**

For coupling Tension Rod and Tie Rod DW26.

Notes

Permissible tension force 250kN.

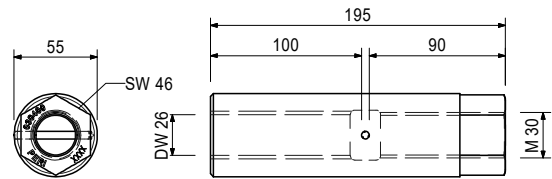
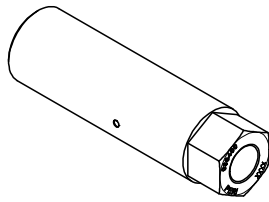

Art no. Weight [kg]

Tension Rods M30 with Nut

027540 5.630 **Tension Rod M30 100 with Nut**

027230 7.570 **Tension Rod M30 135 with Nut**

For anchoring the Brace Frame SB.

Notes

Permissible load 250kN.

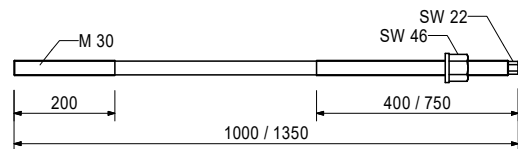
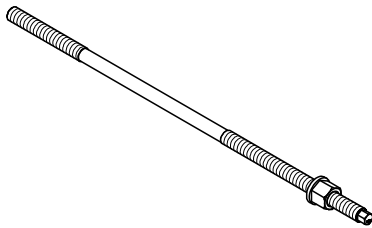

Art no. Weight [kg]

031627 0.967 **Spacer Tube Ø32mm 300 rough**

Plastic spacer tube for DW26.

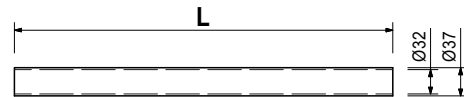
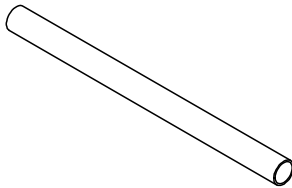

Art no. Weight [kg]

031634 1.250 **Spacer Tube Ø42mm 300 rough**

Plastic spacer tube for DW20 and DW26.

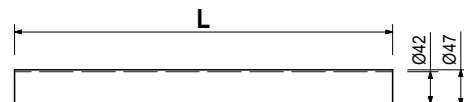
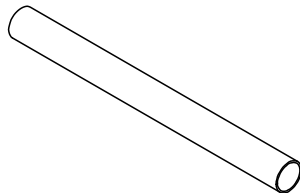

Accessories SB

Art no. Weight [kg]

031631 0.345 **Lead. Anchor Coupler DW15 cpl**

For easy installation of DW15 Tie Rods at 45° inclinations.

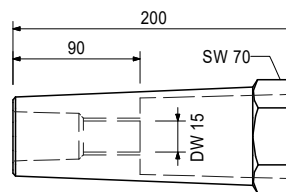
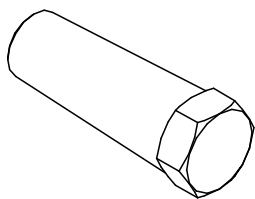

Art no. Weight [kg]

031632 0.355 **Lead. Anchor Coupler DW20 cpl**

For easy installation of DW20 Tie Rods at 45° inclinations.

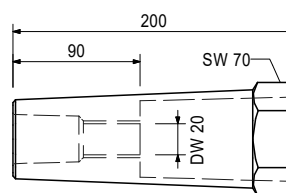
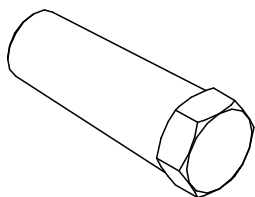

Art no. Weight [kg]

031633 0.365 **Lead. Anchor Coupler DW26 cpl**

For easy installation of DW26 Tie Rods at 45° inclinations.

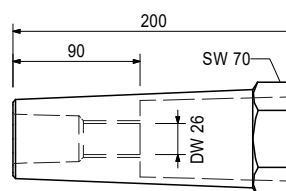
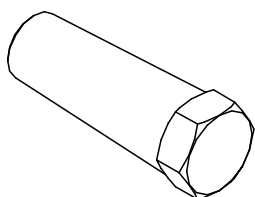

Art no. Weight [kg]

031580 0.440 **V-Tie Holder DW15**

For easy installation of DW15 Tie Rods at 45° inclinations.

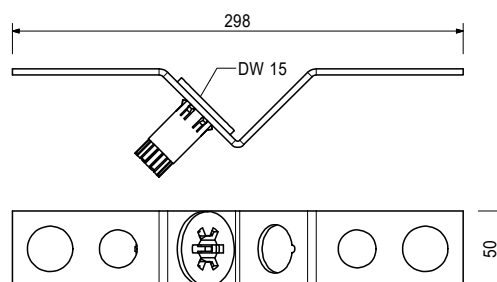
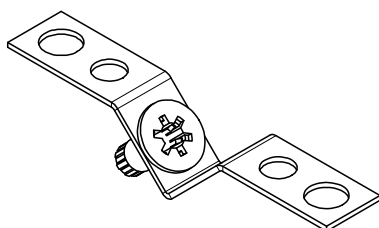

Accessories SB

Art no. Weight [kg]

031590 0.420 **V-Tie Holder DW20**

For easy installation of DW20 Tie Rods at 45° inclinations.

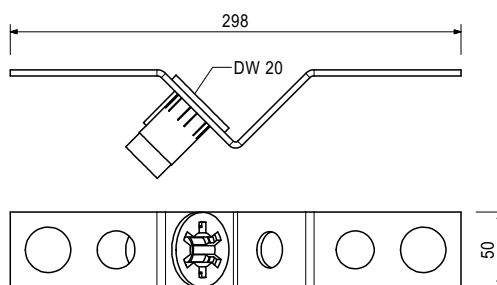
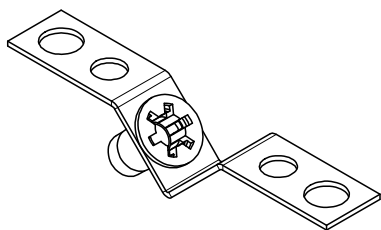

Art no. Weight [kg]

031600 0.430 **V-Tie Holder DW26**

For easy installation of DW26 Tie Rods at 45° inclinations.

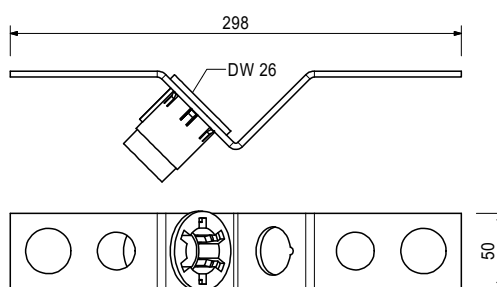
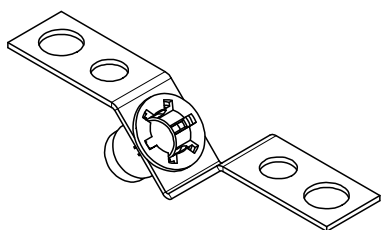

Bracing / Scaffold Tube Bracing SB

Art no.	Weight [kg]		L [mm]
Scaff. Tubes Ø48.3x3.2mm ga			
026417	0.000	Cutting Costs Scaffold Tube	1
125976	8.900	Scaff. Tube 48,3x3,2mm 2,5m ga	2500
114287	12.500	Scaff. Tube 48,3x3,2mm 3,5m ga	3500
026411	3.550	Scaff. Tube 48.3x3.2mm 1m ga	1000
026412	7.100	Scaff. Tube 48.3x3.2mm 2m ga	2000
026413	10.650	Scaff. Tube 48.3x3.2mm 3m ga	3000
026414	14.200	Scaff. Tube 48.3x3.2mm 4m ga	4000
026419	17.750	Scaff. Tube 48.3x3.2mm 5m ga	5000
026418	21.600	Scaff. Tube 48.3x3.2mm 6m ga	6000
026415	3.550	Scaff. Tube 48.3x3.2mm 1fm ga	1000

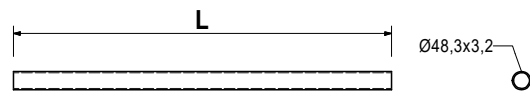
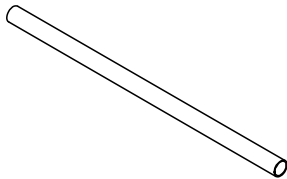

Art no.	Weight [kg]	
110084	2.510	Scaff. Tube Adaptor RCS Ø48mm

For connecting Scaffold Tubes Ø48mm to Climbing Rails RCS.

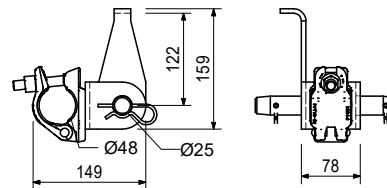
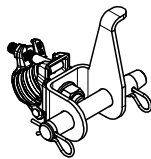

Consists of

- 1 pc 017040 Screw-On Coupler DK 48 ga
- 1 pc 710894 Pin Ø25x180mm coat
- 2 pc 018060 Cotter Pin 4/1 ga

Art no.	Weight [kg]	
017010	1.400	Swivel Coupler SW Ø48/48mm ga

For Scaffold Tubes Ø48mm.

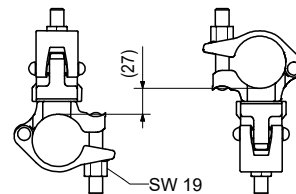
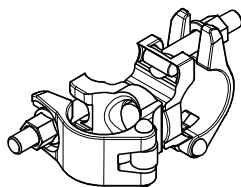

Art no.	Weight [kg]	
017020	1.120	Standard Coupl. RA Ø48/48mm ga

For Scaffold Tubes Ø48mm.

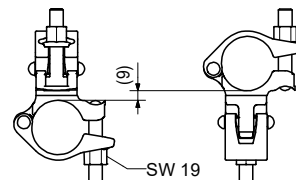
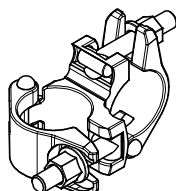

Bracing / Scaffold Tube Bracing SB

Art no. Weight [kg]

131404 1.080 **Screw-On Cou.-2 HT B Ø48mm M20**

For Screwing Scaffold Tubes Ø48mm to components up to 9mm thickness.

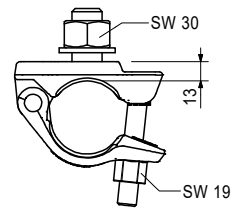
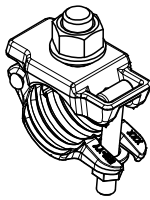

Art no. Weight [kg]

115378 1.080 **Eye Nut RCS DW15**

As an articulated connection to the Climbing Rail RCS, Steel Waler SRU for bracing with DW15.

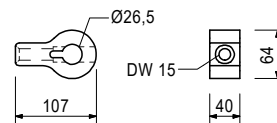

Accessory (not included)

18060	0.014	Cotter Pin 4/1 ga
22230	0.033	Cotter Pin 5/1 ga
104031	0.462	Fitting Pin Ø21x120mm
111567	0.729	Fitting Pin Ø26x120mm

Art no. Weight [kg]

123534 5.910 **Brace Connector RCS/DW15,M20**

For mounting diagonal bracing with Tie Rod DW15 and a compression strut to the Climbing Rail RCS.

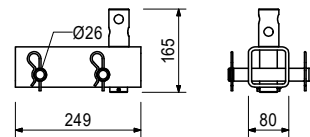
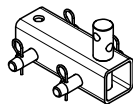

Consists of

- 2 pc 710894 Pin Ø25x180mm coat
- 4 pc 018060 Cotter Pin 4/1 ga

Art no. Weight [kg]

117766 4.450 **Bracing Connector SRU/DW15**

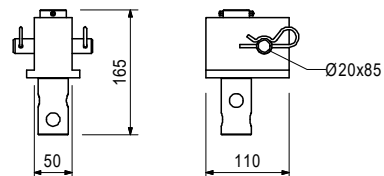
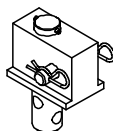

Bracing / Scaffold Tube Bracing SB

Art no.	Weight [kg]	
115626	1.880	Kicker Connector RCS M24

Bolted in holes Ø26 of the Climbing Rail RCS. Serves for connecting Kicker AV or Bracing DW15.

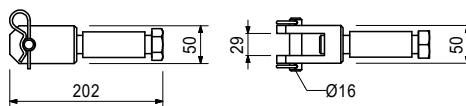
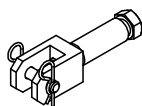

Consists of

- 1 pc 115916 Bolt Ø16x70mm coat
- 2 pc 018060 Cotter Pin 4/1 ga
- 1 pc 109612 Screw ISO4014-M24x130-8.8-ga

Art no.	Weight [kg]	
115332	1.890	Tie Yoke VARIOKIT Ø22mm DW15

For assembling in Steel Waler SRU.

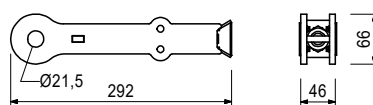
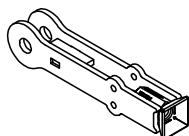

Art no.	Weight [kg]	
115375	6.100	Articulated Spanner RCS DW15

For tensioning and as an articulated connection to the Climbing Rail RCS, Steel Waler SRU or Bracing Shoe RCS for bracing with DW15.

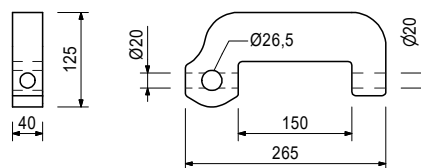
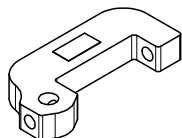

Accessory (not included)

104031	0.462	Fitting Pin Ø21x120mm
018060	0.014	Cotter Pin 4/1 ga
111567	0.729	Fitting Pin Ø26x120mm
022230	0.033	Cotter Pin 5/1 ga
030070	0.222	Hex-Nut DW15 SW30 50mm ga
030030	1.440	Tie Rod DW15 spec. Length

Accessories Formwork SB

Art no. Weight [kg]

110055 0.861 **Cross Strap coat**

For fixing formwork at the Strongbacks by means of Tie Yokes DW15.

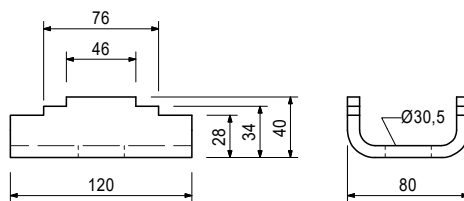
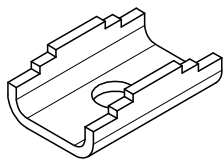

Accessory (not included)

030440 0.686 **Spherical Nut DW15 ga**

Art no. Weight [kg]

722137 0.849 **Cross Strap 2 coat**

For fixing formwork at the Strongbacks by means of Tie Yokes DW15.

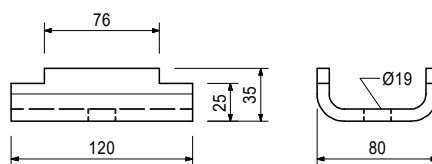
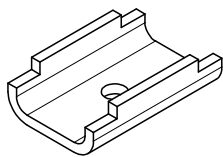

Accessory (not included)

030100 0.439 **Wingnut DW15 ga**

Art no. Weight [kg]

030100 0.439 **Wingnut DW15 ga**

For anchoring with Tie Rod DW15 or B15.

Notes

Permissible load 90kN.

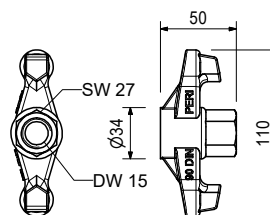

Art no. Weight [kg]

030130 0.318 **Cam Nut DW15 coat**

For anchoring with Tie Rod DW15 or B15.

Notes

Permissible load 90kN.

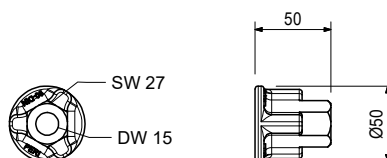
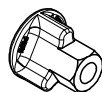

Accessories Formwork SB

Art no. Weight [kg]

030110 0.799 **Wingnut Counterplate DW15 ga**

For anchoring with Tie Rod DW15 or B15.

Notes

Permissible load 90kN.

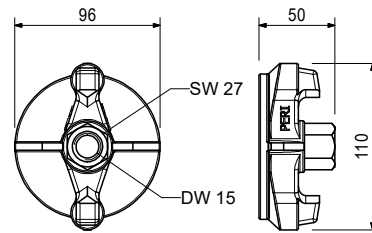

Art no. Weight [kg]

030440 0.686 **Spherical Nut DW15 ga**

For pivotable anchoring with Tie Rod DW15 or B15.

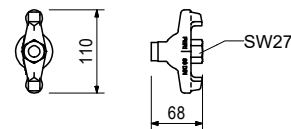

Art no. Weight [kg]

030370 1.660 **Wingnut Pivot Plate DW15 ga**

For anchoring with Tie Rod DW15 or B15.

With articulated, captive nut. Maximum inclination of anchor: 8°.

Notes

Wrench size SW27.

Permissible load 90kN.

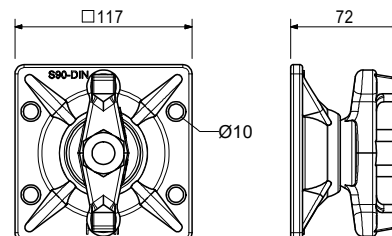
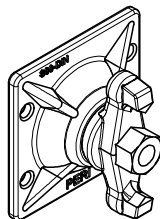

Art no. Weight [kg]

030990 0.786 **Wingnut DW20 ga**

For anchoring with Tie Rod DW20 or B20.

Notes

Permissible load 150kN.

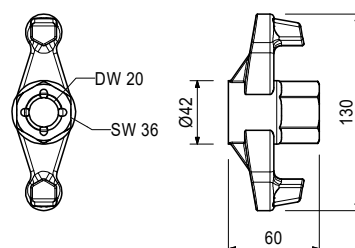

Accessories Formwork SB

Art no. Weight [kg]

127587 3.210 **Wingnut Pivot Plate DW20 ga**

For anchoring with Tie Rod DW20. With pivoting captive nut. Maximum angle of tilting +/- 8°.

Notes

Permissible load 150kN.

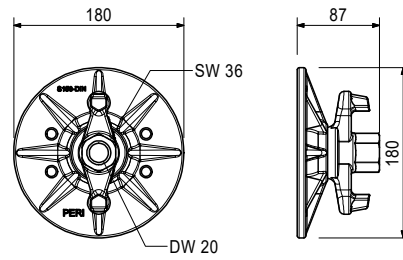
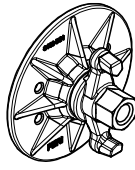

Art no. Weight [kg]

114082 2.860 **Counterplate RCS DW20**

Counterplate with centring for anchoring through the Climbing Rail RCS.

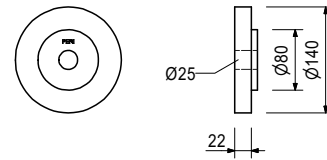

Art no. Weight [kg]

030070 0.222 **Hex-Nut DW15 SW30 50mm ga**

For anchoring with Tie Rod DW15 or B15.

Notes

Weldable!

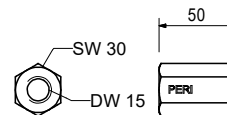

Art no. Weight [kg]

030550 0.233 **Hex-Nut DW15 SW30 50mm weldab**

For anchoring with Tie Rod DW15 or B15.

Notes

Weldable! Permissible load 90kN.

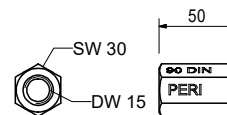

Accessories Formwork SB

Art no. Weight [kg]

030580 0.371 **Hex-Nut DW20 SW36 60mm weldab**

For anchoring with Tie Rod DW20 or B20.

Notes

Weldable! Permissible load 150kN.

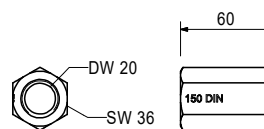
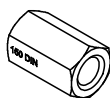

Art no. Weight [kg]

030090 0.402 **Hex-Nut DW15 SW30 108mm ga**

For coupling Tie Rod DW15 resp. B15.

Notes

Permissible load 90kN.

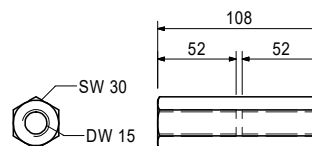
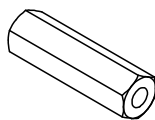

Art no. Weight [kg]

030590 0.685 **Hex-Nut DW20 SW36 110mm weldab**

For coupling Tie Rod DW20 resp. B20.

Notes

Weldable! Permissible load 150kN.

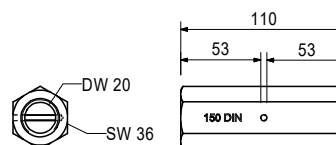
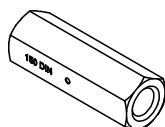

Art no. Weight [kg]

030980 1.540 **Hex-Nut DW26 SW46 150mm weldab**

For coupling Tie Rod DW26.

Notes

Weldable! Permissible load 250kN.

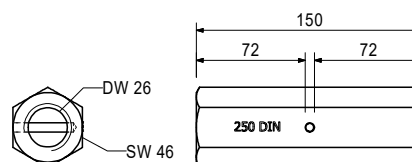
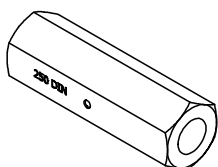

Accessories Formwork SB

Art no. Weight [kg]

113339 0.800 **Hex-Nut DW26 SW46 80mm ga**

For anchoring with Tie Rod DW26.

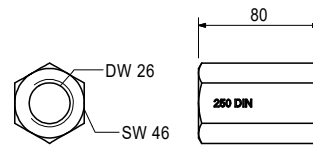
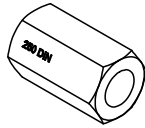

Art no. Weight [kg]

018310 1.810 **Beam Connector ga**

For connecting crossed timbers or girders.

Notes

With captive swivel nuts.

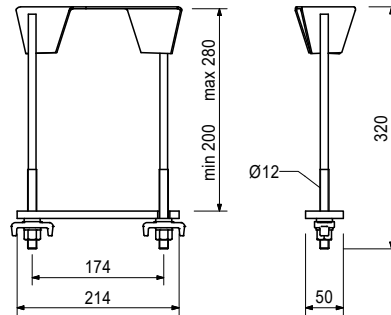
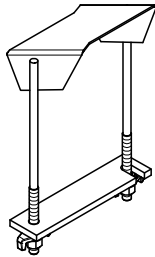

Art no. Weight [kg]

027590 2.400 **Hook Strap SB-2 ga**

For fixing SB-2 to Steel Waler SRZ and SRU Profile U100-U140.

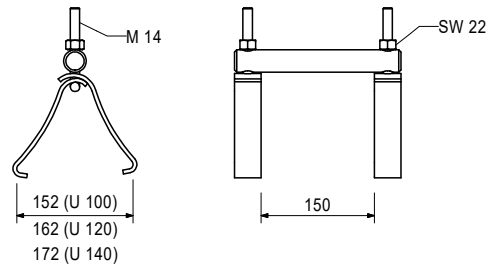
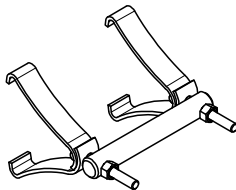

Art no. Weight [kg]

131225 2.080 **Hook Strap SB/DUO**

For the fixation of Brace Frame SB to Compensation Waler DUO 62.

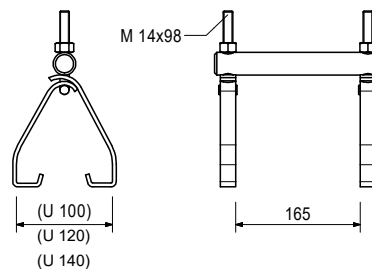
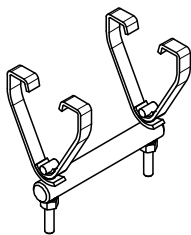

Accessories Formwork SB

Art no. Weight [kg]

116078 3.260 **Hook Strap SB-2 asymmetric**

For fixing Brace Frame SB-2 to Steel Waler SRZ and SRU Profile U100-U140.

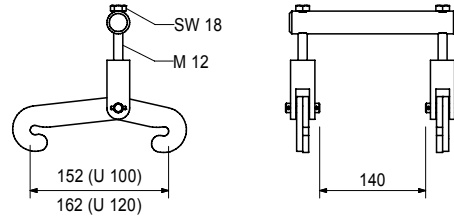
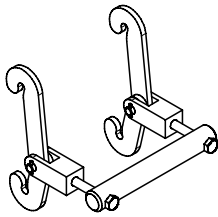

Art no. Weight [kg]

024070 0.691 **Hook Strap 24 U100/U120**

For fixing GT 24 Girders to Steel Walers SRZ, SRU and BR Profile U100-U120.

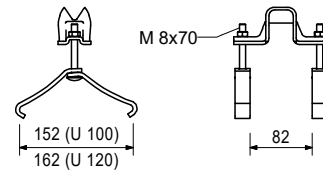
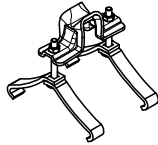

Art no. Weight [kg]

024080 0.735 **Hook Strap 24 U140/U160**

For fixing GT 24 Girders to Steel Walers SRZ, SRU and BR Profile U140-U160.

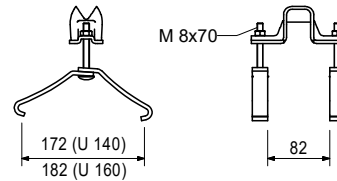
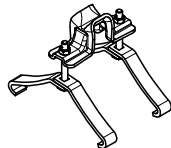

Art no. Weight [kg]

Hook Straps Uni HBU

104931 0.839 **Hook Strap Uni HBU 20-24**

103845 0.893 **Hook Strap Uni HBU 24-28**

For fixing GT 24 Girders or VT 20 Girders to Steel Walers SRZ and SRU Profiles U100-U140.

Notes

The girders can be mounted right-angled or diagonally to the steel walers and also outside of the nodes.

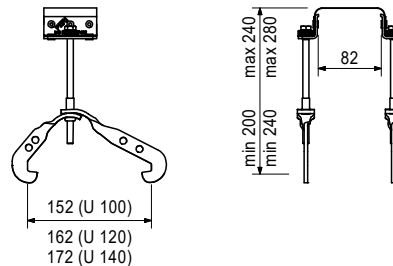
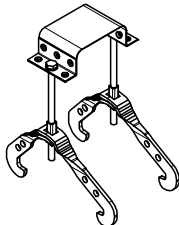

Accessory (not included)

024540 0.005 **Wood-Screw 6x40 SK-TX30 HPI**

Accessories Formwork SB

Art no. Weight [kg]

Hook Straps Uni dou. HBUD

104930	0.887	Hook Strap Uni dou. HBUD 20-24
104096	0.912	Hook Strap Uni dou. HBUD 24-28

For fixing two GT 24 Girders or VT 20 Girders to SRZ Steel Walers and SRU Profiles U100–U140.

Notes

The girders can be mounted right-angled or diagonally to the steel walers and also outside of the nodes.

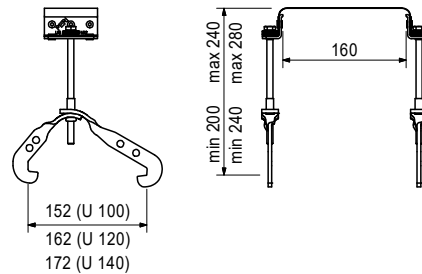
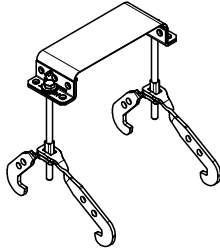

Art no. Weight [kg]

024860 0.616 Hook Strap 24 Cross Bar 150mm

For fixing GT 24 Girders independent from girder node or timber beams with drilling Ø20mm to Steel Walers SRZ, SRU and BR Profile U100–U120.

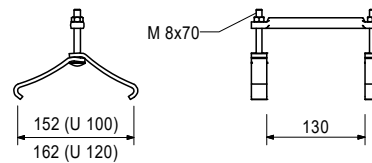
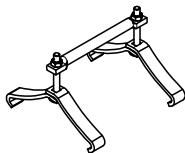

Art no. Weight [kg]

024600 0.907 Girder Claw HB

For mounting the GT 24 Edge Girder on the Steel Waler SRZ and SRU Profile U100–U120.

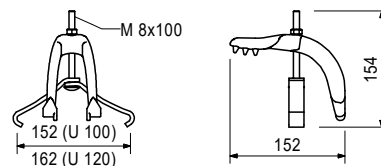
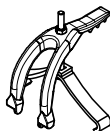

Art no. Weight [kg]

024640 0.923 Impact Strap 24

For fixing GT 24 Girders to Steel Waler SRZ, SRU-Profile U100–U140 outside of the girder nodes.

Notes

Girders fixed in position with the quick strap must be screwed to the formlining when using crane lifting gears.

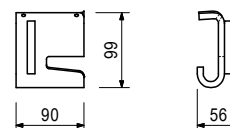
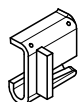

Accessories Formwork SB

Art no. Weight [kg]

024630 0.742 **Fix Clamp ga**

For fixing the GT 24 Girder in the VARIO Corner.

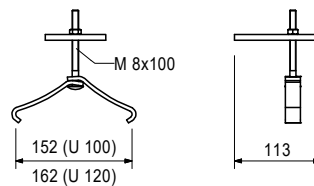
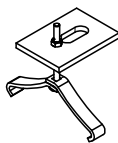

Art no. Weight [kg]

030140 1.620 **Counterplate DW15 120x120x15mm**

For anchoring with Tie Rod DW15 or B15.

Notes

Permissible tension force 90kN.

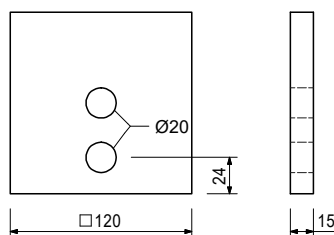
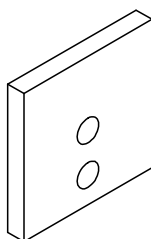

Art no. Weight [kg]

037150 0.641 **Tie Yoke**

For fixing SRZ Steel Walers to the strongback.

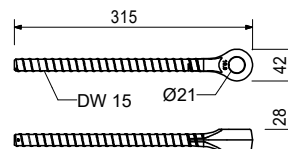

Accessory (not included)

037160	0.736	Pin Ø20x205mm ga
781053	0.065	Hex-Nut ISO7040-M20-8-ga
710226	0.340	Screw ISO4014-M20x090-8.8-ga

Art no. Weight [kg]

110059 2.840 **Waler Fixation U100/U120**

For fixing VARIO GT 24 Panels to Strongbacks CB, SCS and Steel Waler SRU.

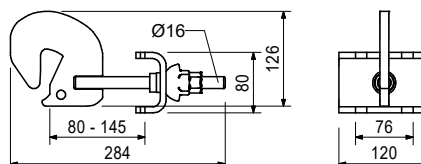
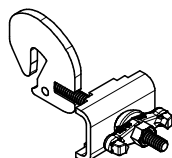

Consists of

- 1 pc 110055 Cross Strap coat
- 1 pc 118260 Spherical Nut RD16 coat

Accessories Formwork SB

Art no. Weight [kg]

129720 8.040 **Waler Fixation U100/U120 doub.**

For fixing VARIO GT 24 Panels to Strongbacks CB, SCS, Steel Waler SRU if anchoring is done through the strongback.

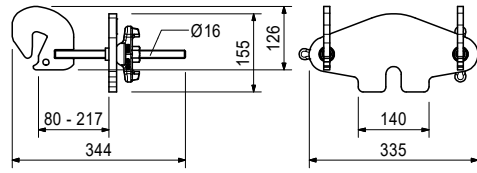
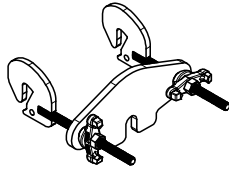

Consists of

2 pc 118260 Spherical Nut RD16 coat

Art no. Weight [kg]

051030 5.530 **Height Adjusting Unit CB,SCS**

For height adjustment of VARIO GT 24 Panels on the Strongbacks CB and SCS.

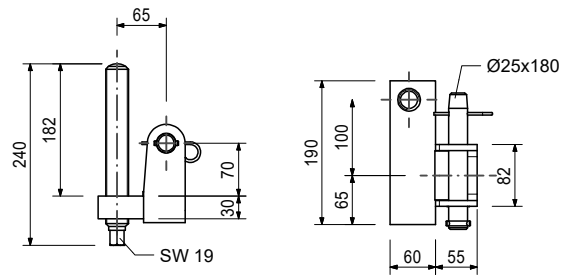
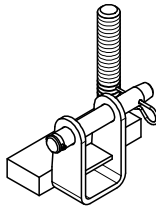

Consists of

1 pc 715936 Pin with Clamping Sleeve
1 pc 018060 Cotter Pin 4/1 ga

Art no. Weight [kg]

111135 5.620 **Adjusting Unit SRU internal**

For internal height adjustment of the formwork on the strongback (Steel Waler SRU) or Climbing Rail RCS.

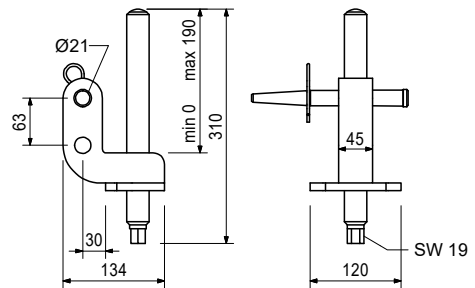
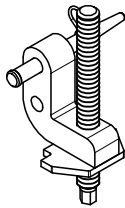

Consists of

1 pc 105400 Pin Ø20x140mm ga
1 pc 018060 Cotter Pin 4/1 ga

Accessories Formwork SB

Art no. Weight [kg]

027520 7.030 **Double Anchor Tie Yoke DSW**

For anchoring with Tie Rod DW15.

Notes

Permissible load 2x90kN.

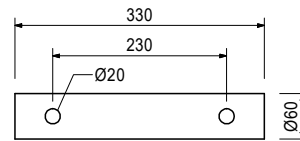
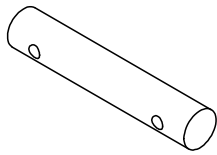

Art no. Weight [kg]

023820 0.375 **Hook Tie Head DW15 ga**

For connecting accessories to MAXIMO and TRIO Panels. DW15 Thread.

Notes

Permissible tension force 20.0kN.

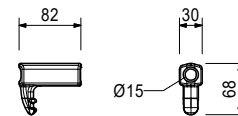

Art no. Weight [kg]

023650 0.769 **Hook Tie DW15x400mm ga**

For connecting accessories to MAXIMO and TRIO Panels. DW15 Thread.

Notes

Permissible tension force 20.0kN.

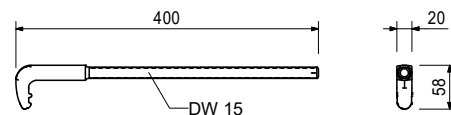
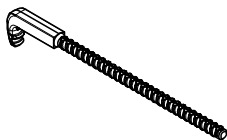

Art no. Weight [kg]

124630 5.330 **Tie Yoke SCS Ø60mm 200mm**

For anchoring of Starter Bar SCS with Tie Rods DW15.

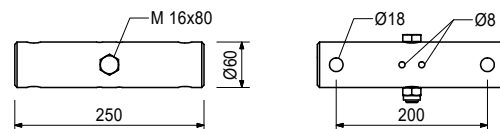
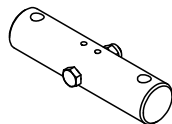

Consists of

- 1 pc 110755 Tie Yoke SRU
- 1 pc 710222 Screw ISO4014-M16x080-8.8-ga
- 1 pc 070890 Hex-Nut ISO7040-M16-8-ga

Accessories Formwork SB

Art no. Weight [kg]

025760 1.300 **Waler Connector SB-A0,A,B,C**

For connecting Steel Walers SRZ and SRU, Profile U100 respectively U120 to SB-A0,A,B,C.

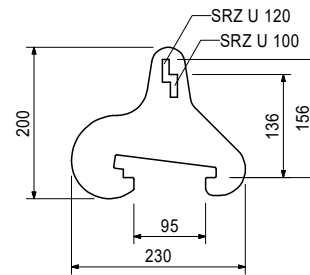
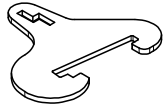

Accessory (not included)

024250 0.331 **Wedge K ga**

Art no. Weight [kg]

024250 0.331 **Wedge K ga**

For Coupling Compression Plate KDP, Wedge Head Piece SRZ/SRU and Waler Connector SB-A,B,C.

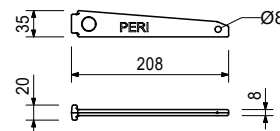

Art no. Weight [kg]

025740 9.140 **Connector SB-A0,A,B,C/TR,MX,D**

For connecting MAXIMO, TRIO and DOMINO Panels with Brace Frames SB-A0,A,B,C.

Notes

1 piece per anchor point.

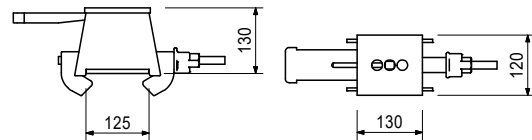
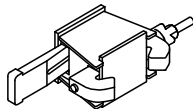

Accessory (not included)

027690 0.371 **Pin SB/TR,D ga**

113255 0.414 **Pin SB/MX ga**

114107 1.190 **Sleeve SB/MX ga**

114417 1.400 **Sleeve SB/MX WDMX**

Accessories Formwork SB

Art no. Weight [kg]

114417	1.400	Sleeve SB/MX WDMX
--------	-------	--------------------------

For connecting MAXIMO Panels to Brace Frames SB.

Notes

Use with elements with MX 15 Interchangeable Seal, part no. 123603 and with MX 18 Interchangeable Seal, part no. 123604.

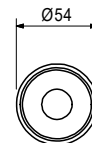
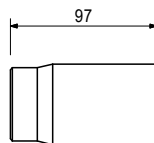
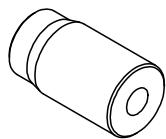

Accessory (not included)

113255	0.414	Pin SB/MX ga
--------	-------	---------------------

Art no. Weight [kg]

114107	1.190	Sleeve SB/MX ga
--------	-------	------------------------

For connecting MAXIMO Panels with Brace Frame SB.

Notes

When using the Sealing Sleeve MX Ø16 art. no. 112342 and the Nut Sealing Sleeve MX Ø16 art. no. 112338 (MAXIMO versions up to 12.2011 without exchangeable seal).

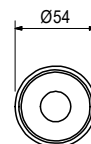
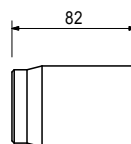
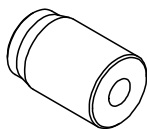

Accessory (not included)

113255	0.414	Pin SB/MX ga
--------	-------	---------------------

Art no. Weight [kg]

027690	0.371	Pin SB/TR,D ga
--------	-------	-----------------------

For panel formwork with 12cm overall thickness.

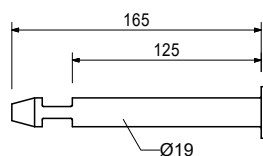
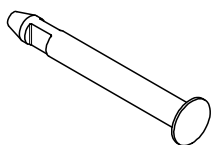

Accessory (not included)

114107	1.190	Sleeve SB/MX ga
114417	1.400	Sleeve SB/MX WDMX

Accessories Formwork SB

Art no. Weight [kg]

113255	0.414	Pin SB/MX ga
--------	-------	---------------------

For connecting MAXIMO Panels with Brace Frame SB.

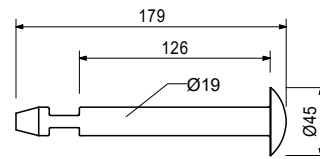
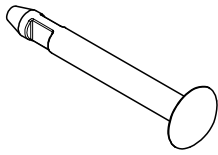

Accessory (not included)

114107	1.190	Sleeve SB/MX ga
114417	1.400	Sleeve SB/MX WDMX

Art no. Weight [kg]

124941	14.100	Compensation Waler-3 MAR 85
--------	--------	------------------------------------

For longitudinal compensation, height extensions, stopend formwork and special applications with MAXIMO. With captive connecting components.

Notes

Permissible bending moment 3.9kNm.

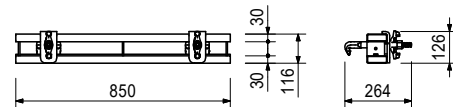
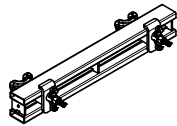

Art no. Weight [kg]

023551	8.520	Waler 85
--------	-------	-----------------

Equivalent to Compensation Waler TAR 85, but without mounting hooks.

Notes

Permissible bending moment 4.4kNm.

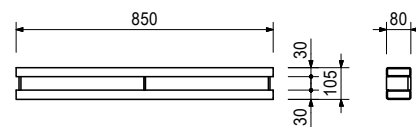
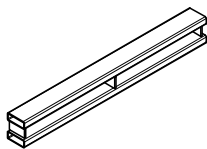

Art no. Weight [kg]

024180	0.126	Compensation Washer Ø20mm ga
--------	-------	-------------------------------------

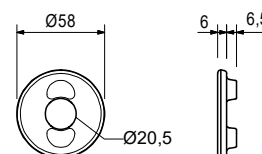

Accessories Formwork SB

Art no. Weight [kg]

027680 49.600 **Connection Rail SB-2/TR,MX,D**

For assembly of Brace Frame SB-2 to MAXIMO, TRIO and DOMINO Panels.

Notes

Permissible load capacity of the load suspension point 1.0t with suspension inclination angle $\leq 15^\circ$.

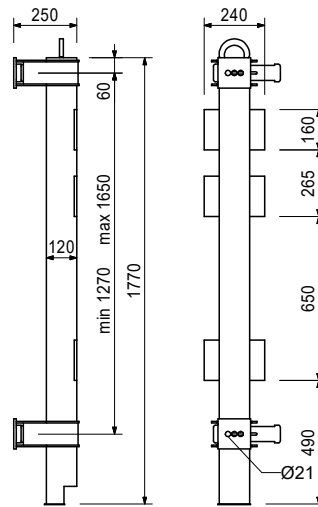
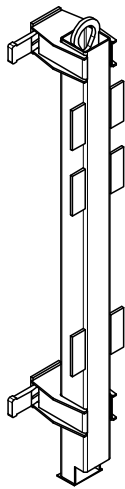

Accessory (not included)

027690	0.371	Pin SB/TR,D ga
027590	2.400	Hook Strap SB-2 ga
113255	0.414	Pin SB/MX ga
114107	1.190	Sleeve SB/MX ga
114417	1.400	Sleeve SB/MX WDMX

Art no. Weight [kg]

109587 4.950 **Connector SB/RFP**

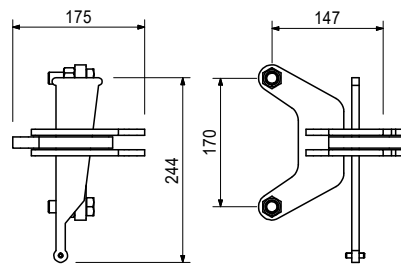
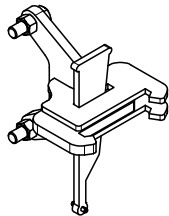

Accessories Formwork SB

Art no.	Weight [kg]		L [mm]
Steel Walers SRU U120			
103868	18.100	Steel Waler SRU 72 U120	722
103871	24.200	Steel Waler SRU 97 U120	972
103874	30.900	Steel Waler SRU 122 U120	1222
103877	38.100	Steel Waler SRU 147 U120	1472
103886	44.700	Steel Waler SRU 172 U120	1722
103889	52.000	Steel Waler SRU 197 U120	1972
103898	58.600	Steel Waler SRU 222 U120	2222
103892	65.600	Steel Waler SRU 247 U120	2472
103929	72.000	Steel Waler SRU 272 U120	2722
103903	81.000	Steel Waler SRU 297 U120	2972
103906	92.600	Steel Waler SRU 347 U120	3472
103915	106.000	Steel Waler SRU 397 U120	3972
103918	119.000	Steel Waler SRU 447 U120	4472
103922	135.000	Steel Waler SRU 497 U120	4972
103925	146.000	Steel Waler SRU 547 U120	5472
103928	159.000	Steel Waler SRU 597 U120	5972

Universal Steel Waler Profile U120 used as waling for girder wall formwork and for diverse special applications. With adjustable spacers.

Notes

Permissible load: see PERI Design Tables.
 SRU 120 $W_y=121.4\text{cm}^3$, $I_y=728\text{cm}^4$.
 SRU 140 $W_y=172,8\text{cm}^3$, $I_y=1210\text{cm}^4$.

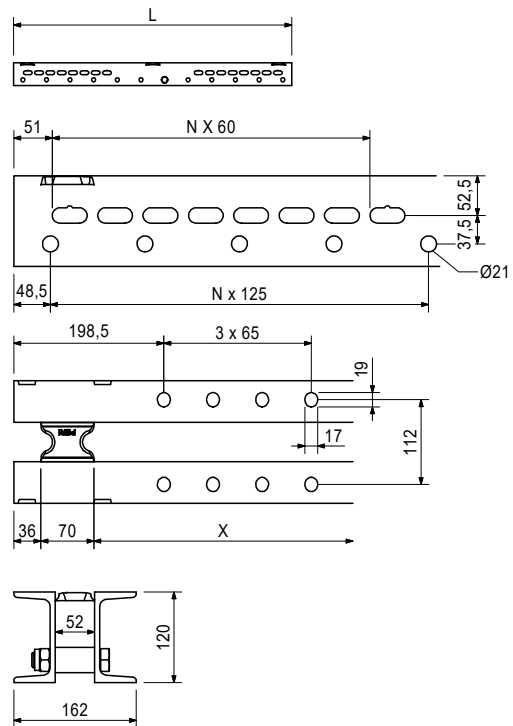
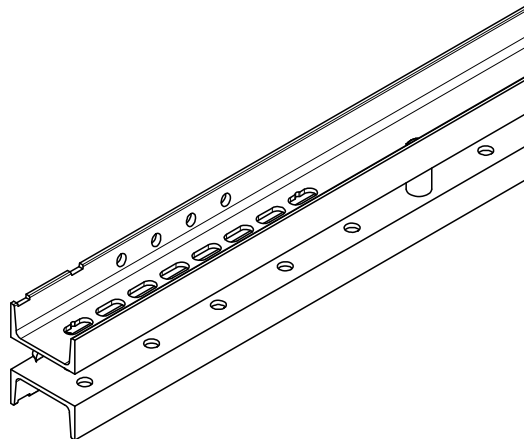

Accessory (not included)

135912	0.067	Spacer SRU
--------	-------	-------------------

Accessories Formwork SB

Art no.	Weight [kg]		L [mm]
Climbing Rails RCS			
114166	78.200	Climbing Rail RCS 148	1480
135990	105.000	Climbing Rail RCS 198	1980
109469	130.000	Climbing Rail RCS 248	2480
112102	156.000	Climbing Rail RCS 298	2980
109470	182.000	Climbing Rail RCS 348	3480
112141	209.000	Climbing Rail RCS 398	3980
109471	262.000	Climbing Rail RCS 498	4980
109472	393.000	Climbing Rail RCS 748	7480
109610	524.000	Climbing Rail RCS 998	9980

Steel profile for all-purpose use of climbing application or civil constructions.

Notes

Wy=357.6cm³, Iy=3576cm⁴.

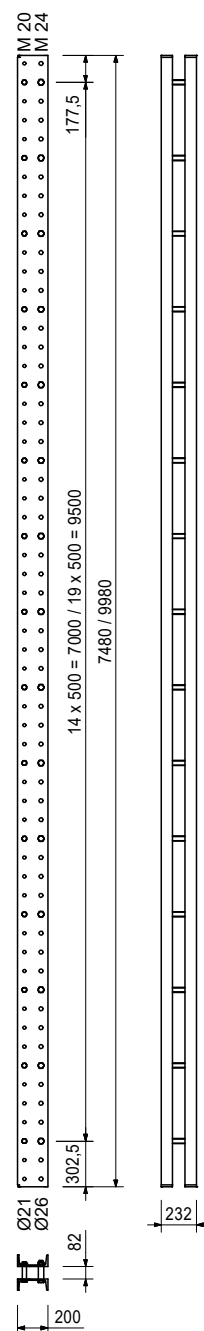
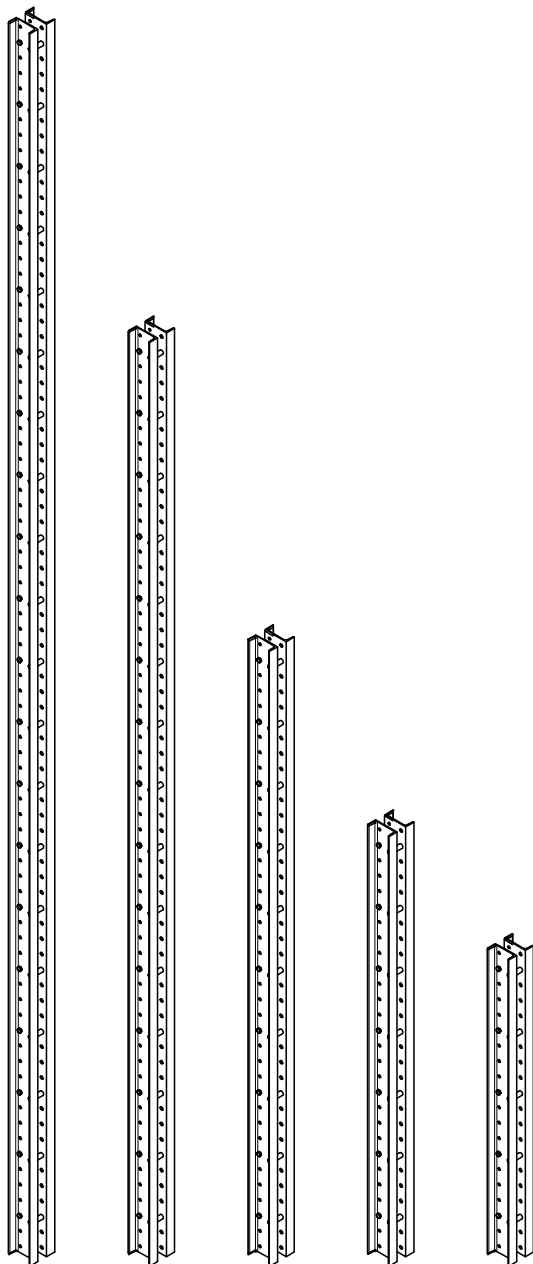

Accessory (not included)

136109	0.472	Pin Set RCS MAX	
--------	-------	------------------------	--

Accessories Formwork SB

Art no. Weight [kg]

129695 0.028 **Reducing Sleeve Ø26/Ø21mm ga**

For reducing the hole diameter from Ø26 to Ø21mm in fitting pin connections.

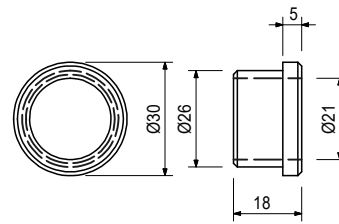
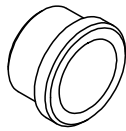

Art no. Weight [kg]

026420 0.123 **Anchor Posit. Stud M24 ga**

For fixing Anchor System M24 if the plywood formlining is not to be drilled through.

Notes

Allen Key SW14.

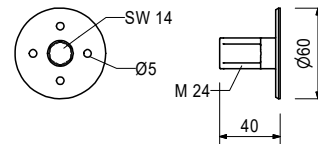

Accessory (not included)

027212 0.445 **Hexag. Recess Wrench SW14 long**

710312 0.005 **Wire Nail 3.0x80mm**

Art no. Weight [kg]

029270 0.331 **Advancing Screw M24 ga**

For fixing the Anchor System M24 if the plywood formlining has been drilled through.

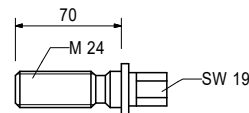
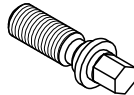

Accessory (not included)

029280 0.196 **Anchor Posit. Plate M24 ga**

Art no. Weight [kg]

029280 0.196 **Anchor Posit. Plate M24 ga**

For fixing the Anchor System M24 if the plywood formlining has been drilled through.

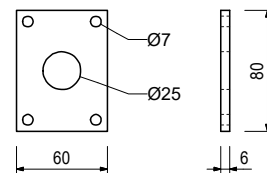
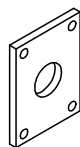

Accessory (not included)

029440 0.005 **Hex-Wood-Screw 6x20 DIN571-ga**

Accessories Formwork SB

Art no.	Weight [kg]	
029380	0.184	Anchor Posit. Plate M30 ga

For fixing the M30 Anchor System if the plywood formlining is drilled through.

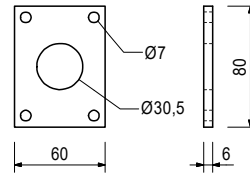
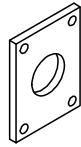

Accessory (not included)

029440	0.005	Hex-Wood-Screw 6x20 DIN571-ga
--------	-------	--------------------------------------

Art no.	Weight [kg]	
029450	0.339	Advancing Screw M30 ga

For fixing the M30 Anchor System if the plywood formlining is drilled through.

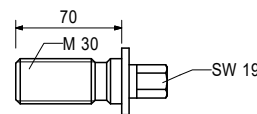
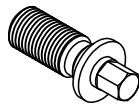

Accessory (not included)

029380	0.184	Anchor Posit. Plate M30 ga
--------	-------	-----------------------------------

Art no.	Weight [kg]	
026450	0.214	Anchor Posit. Stud M30 ga

For fixing the M30 Anchor System if the plywood formlining is not drilled through.

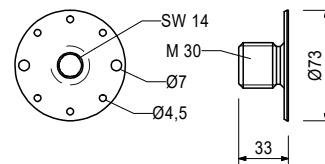

Accessory (not included)

027212	0.445	Hexag. Recess Wrench SW14 long
710312	0.005	Wire Nail 3.0x80mm

Art no.	Weight [kg]		L [mm]
029420	0.590	Screw ISO4017-M30x070-8.8-ga	70

Alternative to Leading Screw M30 galvanized, item number: 029450.

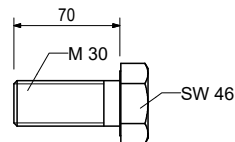
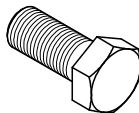

Accessories Formwork SB

Art no. Weight [kg]

029390 0.170 **Anchor Posit. Plate M36 ga**

For fixing the M36 anchor system if the plywood formlining is drilled through.

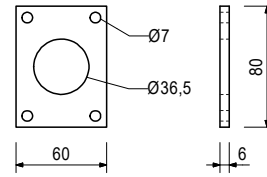
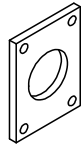

Accessory (not included)

029440 0.005 **Hex-Wood-Screw 6x20 DIN571 galv**

Art no. Weight [kg]

026460 0.308 **Anchor Posit. Stud M36 ga**

For fixing the M36 anchor system if the plywood formlining is not drilled through.

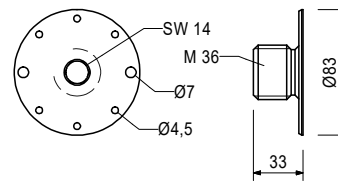
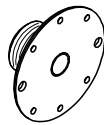

Accessory (not included)

027212 0.445 **Hexag. Recess Wrench SW14 long**

710312 0.005 **Wire Nail 3.0x80mm**

Art no. Weight [kg]

029430 0.930 **Screw ISO4017-M36xØ70-8.8-ga**

L [mm]

70

Bolt for anchoring of climbing systems and as advancing bolt.

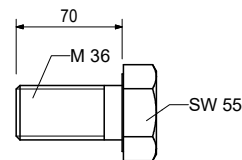
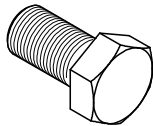

Art no. Weight [kg]

030300 0.002 **Plug Ø20-24mm**

For sealing unused tie holes Ø20 to Ø24mm.

Notes

Delivery unit 250 pieces.

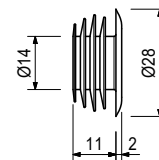
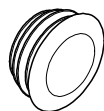

Accessories Formwork SB

Art no. Weight [kg]

057093 0.001 **Plug SFL Ø15x0.8-2mm**

For closing advancing Anchor Holes Ø11mm to Ø13,4mm.

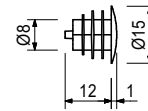

Art no. Weight [kg]

057094 0.004 **Plug SFL Ø38x1-3mm**

For closing advancing Anchor Holes Ø32mm to Ø36mm.

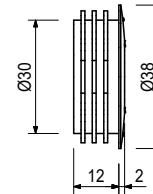
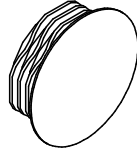

Art no. Weight [kg]

101706 1.230 **Formwork Joint 21/40mm 300**

Plastic profile strip for easier striking of shafts.

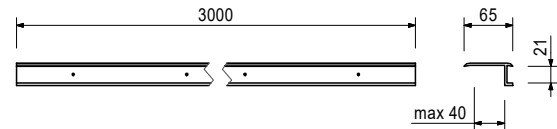
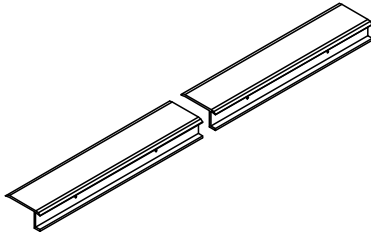

Art no. Weight [kg]

031652 0.247 **Concrete Cone KK M24 Ø67x52mm**

For closing anchor points with Climbing Cone-2, M24/DW15 and Screw-On Cone-2 M24/DW20.

Notes

Delivery unit 50 pieces.

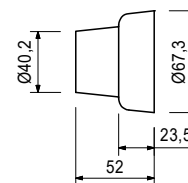
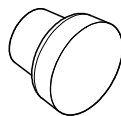

Accessory (not included)

131709 9.980 **Sealing Adhesive-3 6 Cans-Set**

Accessories Formwork SB

Art no. Weight [kg]

031653 0.364 **Concrete Cone KK M30 Ø80x52mm**

For closing anchor points with Climbing Cone-2 M30/DW20 or Screw Cone M30/DW26.

Notes

Delivery Unit 50 pieces.

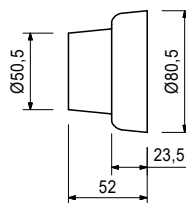
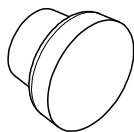

Accessory (not included)

131709 9.980 **Sealing Adhesive-3 6 Cans-Set**

Art no. Weight [kg]

031654 0.512 **Concrete Cone KK M36 Ø90x52mm**

For closing anchor points with Climbing Cone-2 M36/DW26.

Notes

Delivery unit 50 pieces.

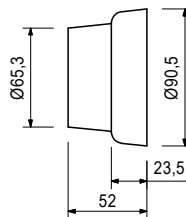
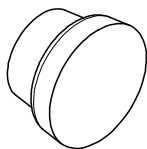

Accessory (not included)

131709 9.980 **Sealing Adhesive-3 6 Cans-Set**

Art no. Weight [kg]

031644 0.588 **Cone Pliers DK Ø58mm**

For holding DK, SK or KK Concrete Cones with corresponding diameter during installation.

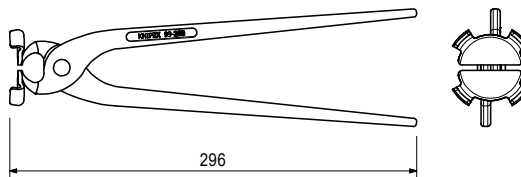
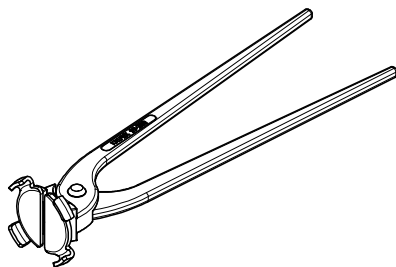

Accessories Formwork SB

Art no. Weight [kg]

131709 9.980 **Sealing Adhesive-3 6-Cans-Set**

For bonding PERI Concrete Cones.

Notes

See Safety Data sheet!

Consisting of: 6 x Component A, 6 x Component B

Component A = Net quantity / Can 459ml / 752g

Component B = Net quantity / Can 356ml / 583g

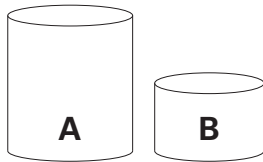

Consists of

6 pc 131710 Sealing Adhesive-3 Can CO-A

6 pc 131711 Sealing Adhesive-3 Can CO-B

Accessories General SB

Art no. Weight [kg]

126088 4.390 **Guardrail Post Holder Multi**

For fixing of an end guardrail post on Girders GT 24, VT 20 or KH 80/160. Fixing of the guardrail posts by means of Hex. Bolts M20.

Notes

Suitable for
 Guardrail Post RCS 226 item no.: 109720
 Guardrail Post RCS/SRU 184 item no.: 114328
 Vertical scaffold tubes
 Special post QR 50x50

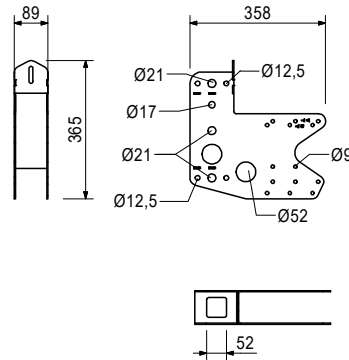
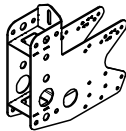

Accessory (not included)

710285	0.050	Screw ISO4014-M08-100-8.8-ga
024090	0.005	Self-cleaning Nut M8 coat
024470	0.008	Wood-Screw 6x60 SK-TX30 HPI

Art no. Weight [kg]

104131 3.940 **Guardrail Holder SRU/SRZ**

For assembling a guardrail to the Steel Walers SRU and SRZ, Profile U100 to U140.

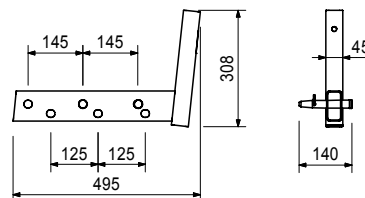
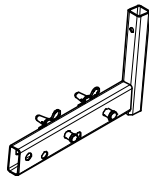

Accessory (not included)

116292	4.720	Guardrail Post-2 HSGP
061260	6.150	Guardrail Post SGP

Consists of

2 pc 105400 Pin Ø20x140mm ga
 2 pc 018060 Cotter Pin 4/1 ga

Accessories General SB

Art no.	Weight [kg]	
101290	5.670	Guardrail Holder GT 24/VT 20

For assembling a guardrail to GT 24 and VT 20 Girders.

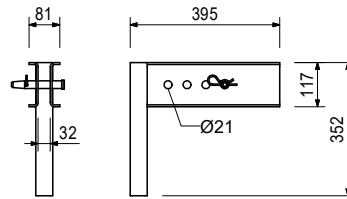
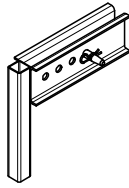

Accessory (not included)

116292	4.720	Guardrail Post-2 HSGP
061260	6.150	Guardrail Post SGP

Consists of

- 1 pc 105400 Pin Ø20x140mm ga
- 1 pc 018060 Cotter Pin 4/1 ga

Art no.	Weight [kg]	
114557	6.980	Platform Beam SRU

For assembling a platform and guardrail at vertical Steel Waler SRU.

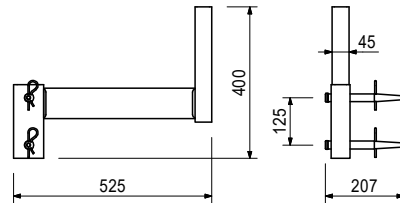
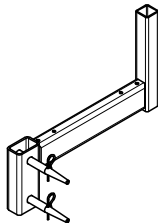

Accessory (not included)

116292	4.720	Guardrail Post-2 HSGP
--------	-------	------------------------------

Consists of

- 2 pc 104031 Fitting Pin Ø21x120mm
- 2 pc 018060 Cotter Pin 4/1 ga

Art no.	Weight [kg]	
111283	9.950	Connector RCS/SRU

For right-angled connection of Steel Walers SRU to the Climbing Rails RCS and for attaching guardrail posts to Steel Walers SRU.

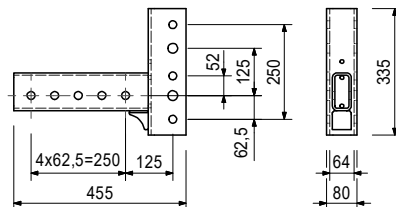
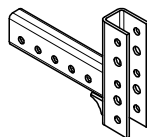

Accessory (not included)

104031	0.462	Fitting Pin Ø21x120mm
018060	0.014	Cotter Pin 4/1 ga
111567	0.729	Fitting Pin Ø26x120mm
022230	0.033	Cotter Pin 5/1 ga

Accessories General SB

Art no. Weight [kg]

116363 0.089 **Spacer RCS 184**

Compensator between Angle Connector RCS/SRU and Guardrail Post RCS 184.

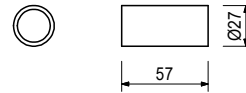

Art no. Weight [kg]

114328 16.600 **Guardrail Post RCS/SRU 184**

For assembly of the guardrail on the Platform Beam RCS/SRU or Guardrail Post Holder Multi.

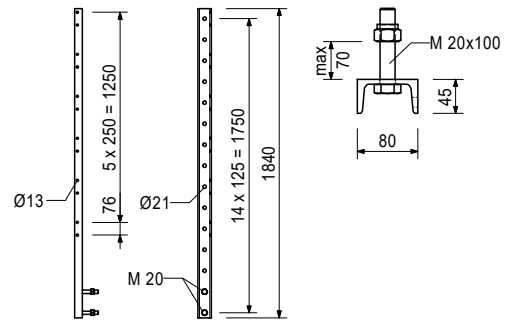

Accessory (not included)

780354	0.002	Washer ISO7089-08-200HV-ga
110296	0.220	Clamp A64 DIN3570-M12-ga
710330	0.017	Hex-Nut ISO4032-M12-8-ga
710709	0.036	Screw DIN603-M08x065-4.8-ga-Nu
057345	0.010	Washer 9mm DIN434 ga

Consists of

- 2 pc 114727 Screw ISO4017-M20x100-8-8-ga
- 2 pc 781053 Hex-Nut ISO7040-M20-8-ga

Accessories General SB

Art no.	Weight [kg]	
109720	26.600	Guardrail Post RCS 226

For assembly of the guardrail on the main platform with RCS Climbing System or on Guardrail Post Holder Multi .

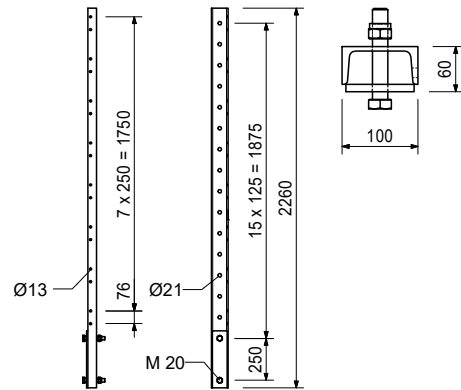

Accessory (not included)

110296	0.220	Clamp A64 DIN3570-M12-ga
710330	0.017	Hex-Nut ISO4032-M12-8-ga
710709	0.036	Screw DIN603-M08x065-4.8-ga-Nu
780354	0.002	Washer ISO7089-08-200HV-ga
057345	0.010	Washer 9mm DIN434 ga

Consists of

- 2 pc 104477 Screw ISO4014-M20x120-8.8-ga
- 2 pc 781053 Hex-Nut ISO7040-M20-8-ga

Art no.	Weight [kg]	
		Guardrail Posts RCS
109773	67.900	Guardrail Post 509 RCS
109721	40.700	Guardrail Post 384 RCS

For assembly of the guardrail on the intermediate and finishing platforms with RCS Climbing System or as horizontal strut in the bracing.

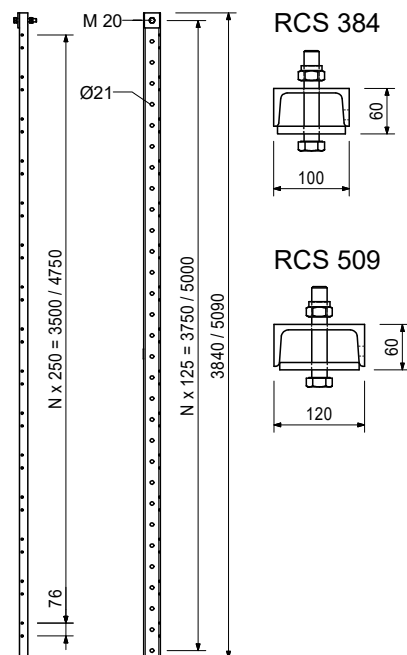

Consists of

- 1 pc 104477 Screw ISO4014-M20x120-8.8-ga
- 1 pc 781053 Hex-Nut ISO7040-M20-8-ga

Accessories General SB

Art no.	Weight [kg]	
110296	0.220	Clamp A64 DIN3570-M12-ga

For assembling Scaffold Tubes on Railing Posts RCS.

Notes

Wrench size SW19.

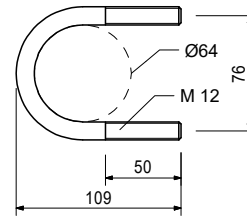
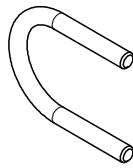

Accessory (not included)

710330	0.017	Hex-Nut ISO4032-M12-8-ga
--------	-------	---------------------------------

Art no.	Weight [kg]		L [mm]
		Scaff. Tubes 48.3x3.2mm ga	
026417	0.000	Cutting Costs Scaffold Tube	1
125976	8.900	Scaff. Tube 48,3x3,2mm 2,5m ga	2500
114287	12.500	Scaff. Tube 48,3x3,2mm 3,5m ga	3500
026411	3.550	Scaff. Tube 48.3x3.2mm 1m ga	1000
026412	7.100	Scaff. Tube 48.3x3.2mm 2m ga	2000
026413	10.650	Scaff. Tube 48.3x3.2mm 3m ga	3000
026414	14.200	Scaff. Tube 48.3x3.2mm 4m ga	4000
026419	17.750	Scaff. Tube 48.3x3.2mm 5m ga	5000
026418	21.600	Scaff. Tube 48.3x3.2mm 6m ga	6000
026415	3.550	Scaff. Tube 48.3x3.2mm 1fm ga	1000

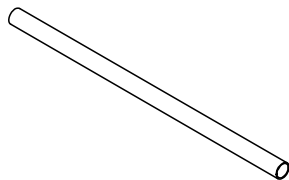

Art no.	Weight [kg]	
019040	6.480	Guardrail Post PD8

As guardrail for different systems. Screwed onto sub-structure.

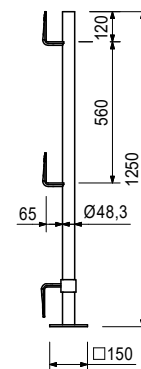
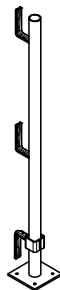

Accessories General SB

Art no. Weight [kg]

116292 4.720 **Guardrail Post-2 HSGP**

As guardrail for different systems.

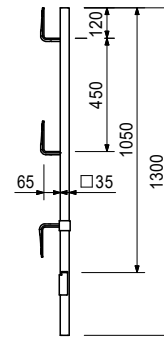

Art no. Weight [kg]

061260 6.150 **Guardrail Post SGP**

As guardrail for different systems.

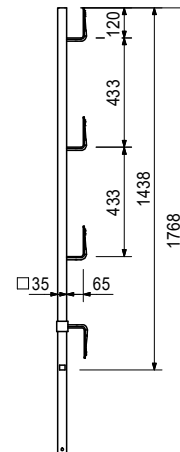

Art no. Weight [kg]

117325 4.270 **Post PP**

For the fixation of the Side-Mesh-Barriers.

Notes

Distance of posts with Side-Mesh-Barrier PMB 260 max. 2.4m.

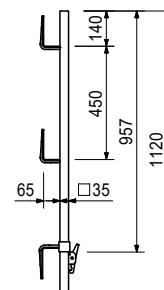

Accessories General SB

Art no. Weight [kg]

110330 0.865 **Girder Connector M20**

For the fixation of 80mm wide decking supports made of wood on Platform Beams with suitable boring of Ø21mm.

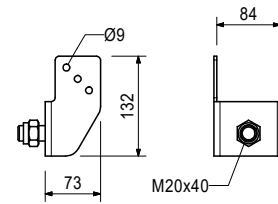
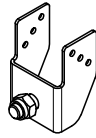

Accessory (not included)

024470 0.008 **Wood-Screw 6x60 SK-TX30 HPI**

Consists of

1 pc 706458 Screw ISO4017-M20x040-8.8-ga

1 pc 781053 Hex-Nut ISO7040-M20-8-ga

Art no. Weight [kg]

129724 0.817 **Cross Connector GT 24/GT 24**

For the connection of crossing GT 24 Formwork Girders.

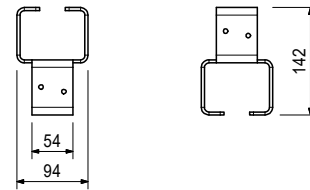

Accessory (not included)

024540 0.005 **Wood-Screw 6x40 SK-TX30 HPI**

024470 0.008 **Wood-Screw 6x60 SK-TX30 HPI**

Art no. Weight [kg]

129722 0.746 **Cross Connector GT 24/VT 20**

For connecting a Girder GT 24 to a crossing Girder VT 20.

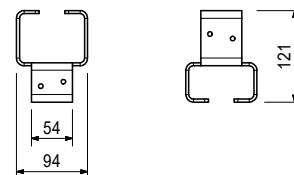

Accessory (not included)

024540 0.005 **Wood-Screw 6x40 SK-TX30 HPI**

024470 0.008 **Wood-Screw 6x60 SK-TX30 HPI**

Accessories General SB

Art no.	Weight [kg]	
129817	0.675	Cross Connector VT 20/VT 20

For the connection of crossing Girders VT 20.

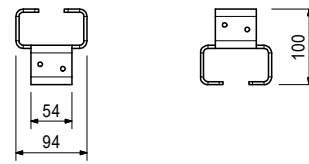
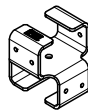

Accessory (not included)

024540	0.005	Wood-Screw 6x40 SK-TX30 HPI
024470	0.008	Wood-Screw 6x60 SK-TX30 HPI

Art no.	Weight [kg]		min. L [mm]	max. L [mm]
Heavy-Duty Spindles SLS				
111035	12.000	Heavy Duty Spindle SLS 40-80	400	800
101773	15.300	Heavy Duty Spindle SLS 80-140	800	1400
101774	18.300	Heavy Duty Spindle SLS 100-180	1000	1800
101776	24.900	Heavy Duty Spindle SLS 140-240	1400	2400
101778	32.300	Heavy Duty Spindle SLS 200-300	2000	3000
101779	38.500	Heavy Duty Spindle SLS 260-360	2600	3600
109726	44.800	Heavy Duty Spindle SLS 320-420	3200	4200
109785	51.000	Heavy Duty Spindle SLS 380-480	3800	4800

Used as adjustable spindle for truss beams made of Steel Walers SRU and Climbing Rails RCS.

Notes

Permissible load see PERI Design Tables.

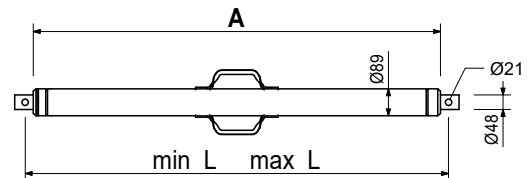
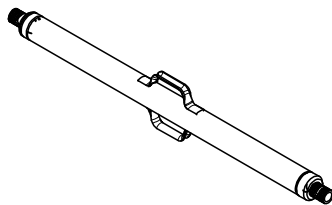

Accessory (not included)

18060	0.014	Cotter Pin 4/1 ga
104031	0.462	Fitting Pin Ø21x120mm
110477	3.990	Spindle Adaptor SLS/RCS

Accessories General SB

Art no.	Weight [kg]	
110477	3.990	Spindle Adaptor SLS/RCS

For connecting the Heavy-Duty Spindle SLS to the Climbing Rail RCS.

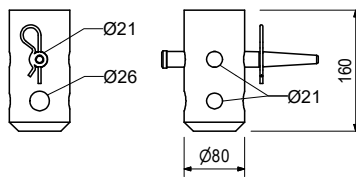
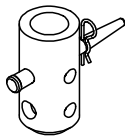

Accessory (not included)

104031	0.462	Fitting Pin Ø21x120mm
018060	0.014	Cotter Pin 4/1 ga
111567	0.729	Fitting Pin Ø26x120mm
022230	0.033	Cotter Pin 5/1 ga

Consists of

- 1 pc 104031 Fitting Pin Ø21x120mm
- 1 pc 018060 Cotter Pin 4/1 ga

Art no.	Weight [kg]	
115388	1.910	Forkhead Adapter SLS/RCS

For horizontal bracing of the climbing protection panel against the Slab Stopend Shoe RCS with a Heavy Duty Spindle SLS.

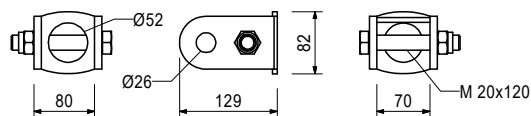
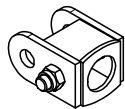

Consists of

- 1 pc 104477 Screw ISO4014-M20x120-8.8-ga
- 1 pc 781053 Hex-Nut ISO7040-M20-8-ga

Art no.	Weight [kg]	
116039	4.910	Spindle Adaptor SKS/RCS

For connecting the Compression Spindle SCS/RCS to the Climbing Rail RCS.

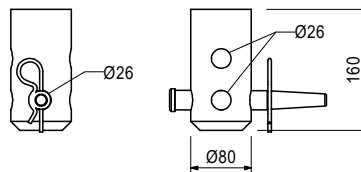
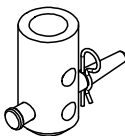

Accessory (not included)

111567	0.729	Fitting Pin Ø26x120mm
022230	0.033	Cotter Pin 5/1 ga

Consists of

- 1 pc 111567 Fitting Pin Ø26x120mm
- 1 pc 022230 Cotter Pin 5/1 ga

Accessories General SB

Art no. Weight [kg]

115298	4.210	Spindle Shoe SLS/RCS M24
--------	-------	---------------------------------

For horizontal bracing of the climbing protection panel against the Advancing Anchor M24 with a Heavy Duty Spindle SLS.

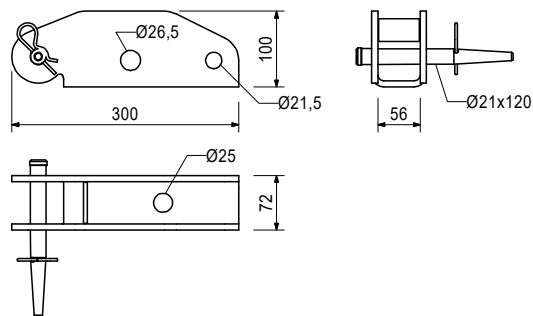
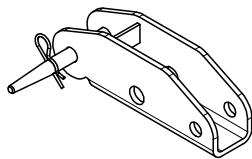

Accessory (not included)

104031	0.462	Fitting Pin Ø21x120mm
111567	0.729	Fitting Pin Ø26x120mm

Consists of

- 1 pc 104031 Fitting Pin Ø21x120mm
- 1 pc 018060 Cotter Pin 4/1 ga

Accessories General SB

Art no.	Weight [kg]		L [mm]
Girders GT 24			
075100	5.300	Girder GT 24 90	918
075120	7.100	Girder GT 24 120	1214
075150	8.900	Girder GT 24 150	1510
075180	10.600	Girder GT 24 180	1806
075210	12.400	Girder GT 24 210	2102
075240	14.200	Girder GT 24 240	2398
075270	15.900	Girder GT 24 270	2694
075300	17.700	Girder GT 24 300	2990
075330	19.500	Girder GT 24 330	3286
075360	21.200	Girder GT 24 360	3582
075390	23.000	Girder GT 24 390	3878
075420	24.800	Girder GT 24 420	4174
075450	26.600	Girder GT 24 450	4470
075480	28.300	Girder GT 24 480	4766
075510	30.100	Girder GT 24 510	5062
075540	31.900	Girder GT 24 540	5358
075570	33.600	Girder GT 24 570	5654
075600	35.400	Girder GT 24 600	5950

Universal formwork girder made of wood.

Notes

Special lengths over 6m are possible and can be provided on request.

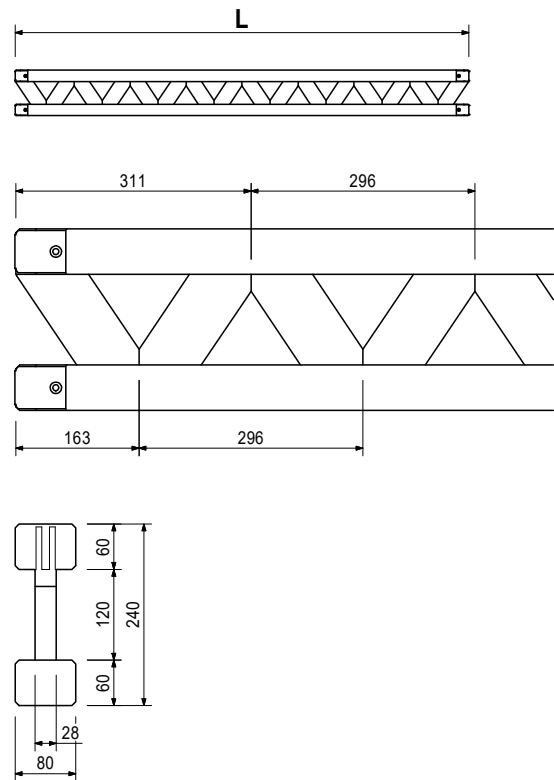
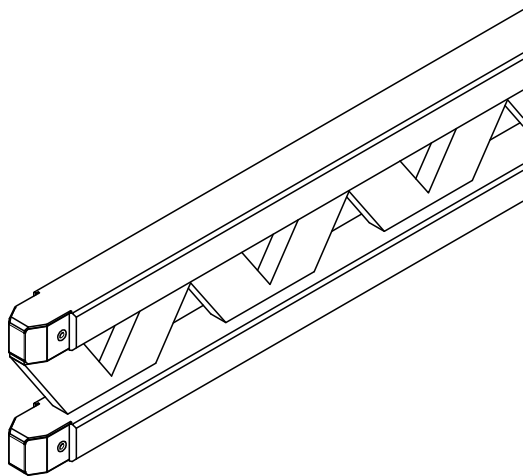

Art no.	Weight [kg]	
078010	36.875	Girder GT 24 625 spec. Length

Accessories General SB

Art no.	Weight [kg]		L [mm]
Girders VT 20K			
074990	8.230	Girder VT 20K 145	1447
074905	12.010	Girder VT 20K 215	2152
074910	13.630	Girder VT 20K 245	2452
074890	14.710	Girder VT 20K 265	2652
074920	16.060	Girder VT 20K 290	2902
074930	18.220	Girder VT 20K 330	3292
074940	19.840	Girder VT 20K 360	3592
074950	21.460	Girder VT 20K 390	3892
074960	24.700	Girder VT 20K 450	4492
074970	26.860	Girder VT 20K 490	4902
074980	32.260	Girder VT 20K 590	5902

Universal formwork girder made of wood.

Notes

The girder fulfils all requirements of DIN EN 13377 class P20 (Declaration of Conformity).

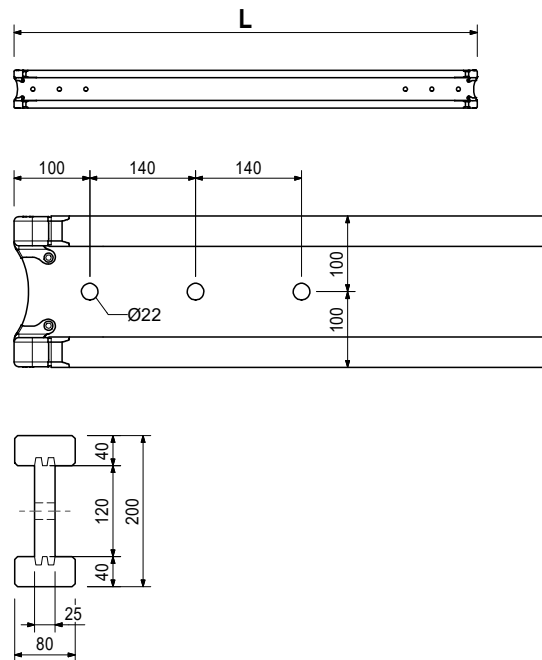
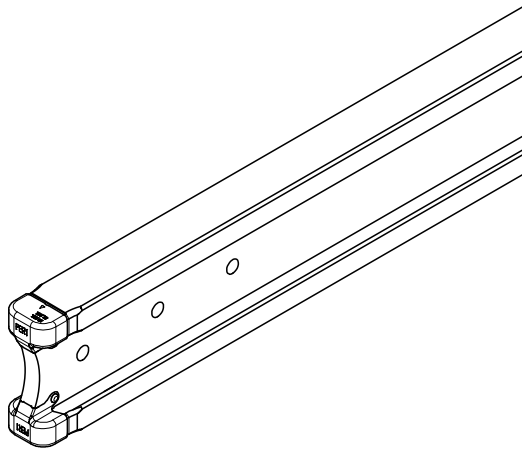

Accessories General SB

Art no.	Weight [kg]	
		Girders VT 20 Alpha
073650	7.830	Girder VT 20 Alpha 145
073651	11.610	Girder VT 20 Alpha 215
073652	13.230	Girder VT 20 Alpha 245
073653	14.310	Girder VT 20 Alpha 265
073654	15.660	Girder VT 20 Alpha 290
073655	17.820	Girder VT 20 Alpha 330
073656	19.440	Girder VT 20 Alpha 360
073657	21.060	Girder VT 20 Alpha 390
073658	24.300	Girder VT 20 Alpha 450
073659	26.460	Girder VT 20 Alpha 490
073660	31.860	Girder VT 20 Alpha 590

Universal formwork girder made of wood.

Notes

The girder fulfils all requirements of DIN EN 13377 class P20 (Declaration of Conformity).

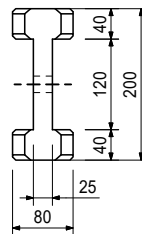
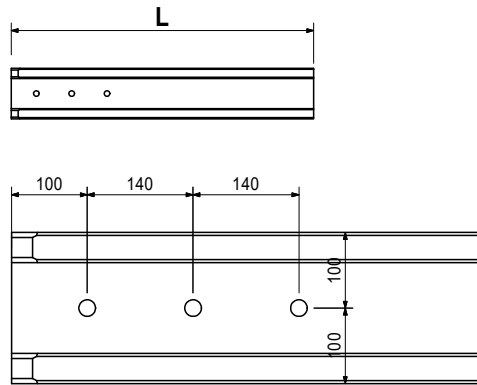
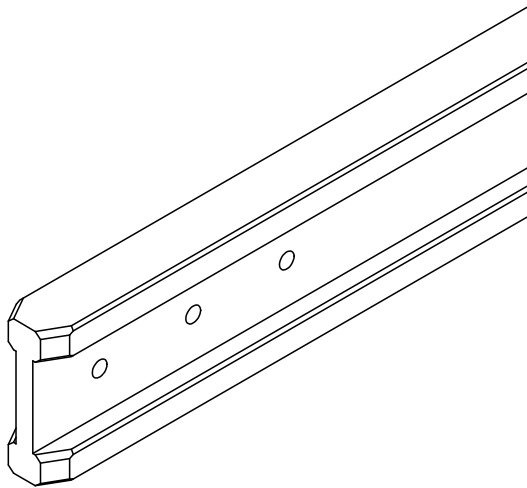

Art no.	Weight [kg]	
123478	0.255	Angle Connector 90x90x65mm

For diverse timber connections.

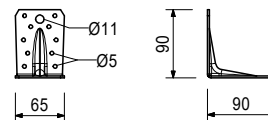

Accessory (not included)

129711	0.010	Wood Screw 6x20 HRK-TX30 HSX
024550	0.005	Wood-Screw 8x20 SK-TX30 HSX

Accessories General SB

Art no. Weight [kg]

018290 0.098 **Framing Clip ga**

For various wood connections.

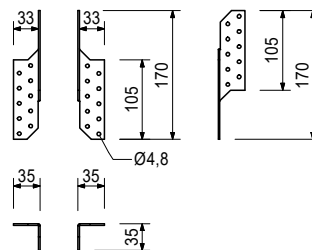
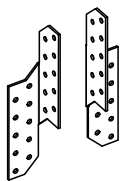

Accessory (not included)

018280 1.000 **Double Head Nail 65mm**

Art no. Weight [kg]

110289 4.260 **L-Angle RCS 120x120x200mm**

For fixing end handrail posts on the decking.

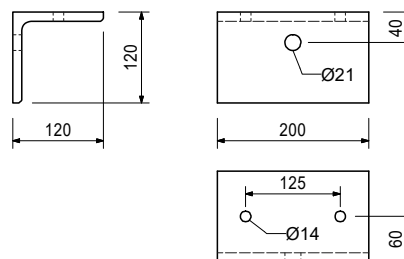
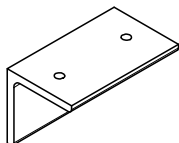

Accessory (not included)

131404 1.080 **Screw-On Cou.-2 HT B Ø48mm M20**

Art no. Weight [kg]

070030 0.015 **Plate Conn. Ø50/12mm single**

To strengthen the timber fixation and for other connections of timber with steel.

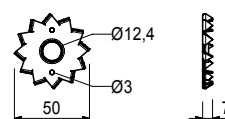
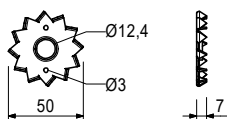

Art no. Weight [kg]

114937 0.402 **Fixation Bar RCS**

For fixing the cover flap to the climbing protection panel during climbing.

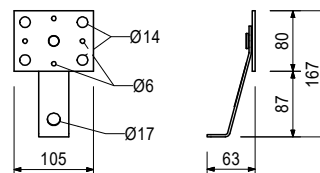
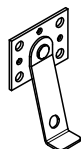

Accessory (not included)

111437 0.004 **Wood-Screw 5x20 SK-TX25 HSX**

Accessories General SB

Art no.	Weight [kg]	
111436	0.150	Hinge DIN7957-200-ST-zn

For mounting the cover flap at the climbing protection panel.

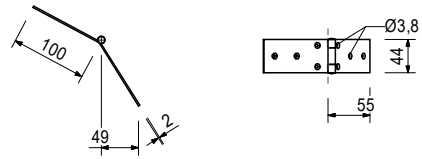
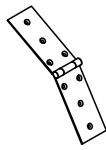

Accessory (not included)

111437	0.004	Wood-Screw 5x20 SK-TX25 HSX
110642	0.006	Wood Screw 5x40 SK-TX20 HSX

Art no.	Weight [kg]	
027110	11.000	Scaffold Bracket GB80

For assembly of a working and concreting scaffold with GT 24 Girder.

Notes

Permissible load 150kg/m².
Maximum width of influence 1.25m.

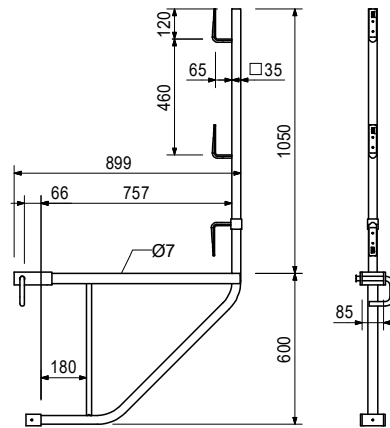
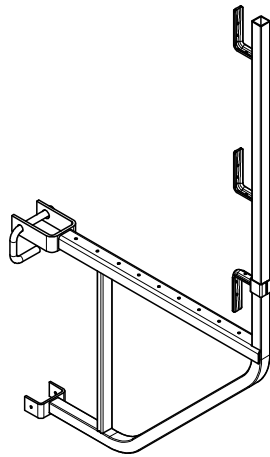

Art no.	Weight [kg]	
023680	16.600	Scaffold Bracket TRG 120

For assembly of a working and concreting scaffold at MAXIMO or TRIO Panels.
Mounting on horizontal or vertical struts is possible.

Notes

Automatically secured by hooking.
Permissible load 150kg/m² with maximum width of influence 1.35m.

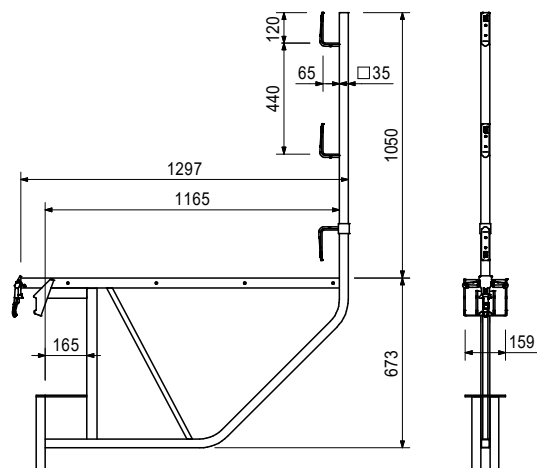
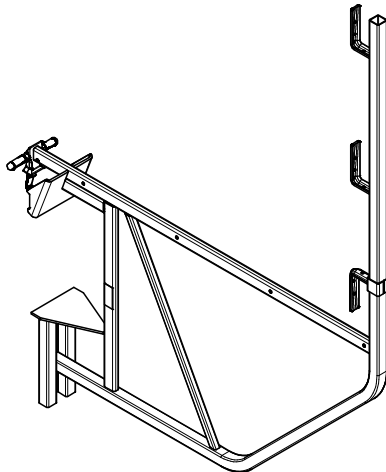

Accessories General SB

Art no. Weight [kg]

023670 12.500 **Scaffold Bracket TRG 80**

For assembly of a working and concreting scaffold at MAXIMO or TRIO Panels.
Mounting on horizontal or vertical struts is possible.

Notes

Permissible load 150kg/m² with maximum width of influence 1.35m.

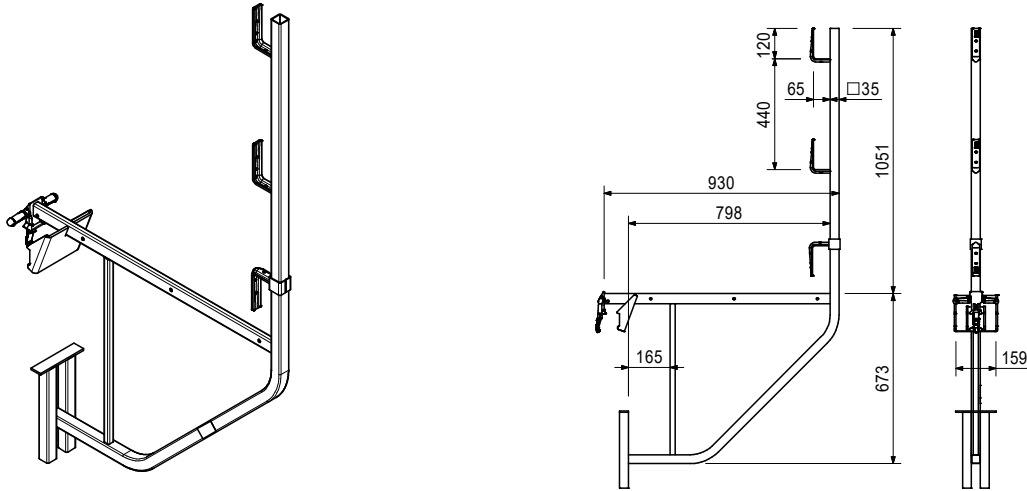

Art no. Weight [kg]

065066 14.800 **End Guardrail Frame 55**

End guardrail for clamping to all PERI Scaffold Platforms and Climbing Systems.

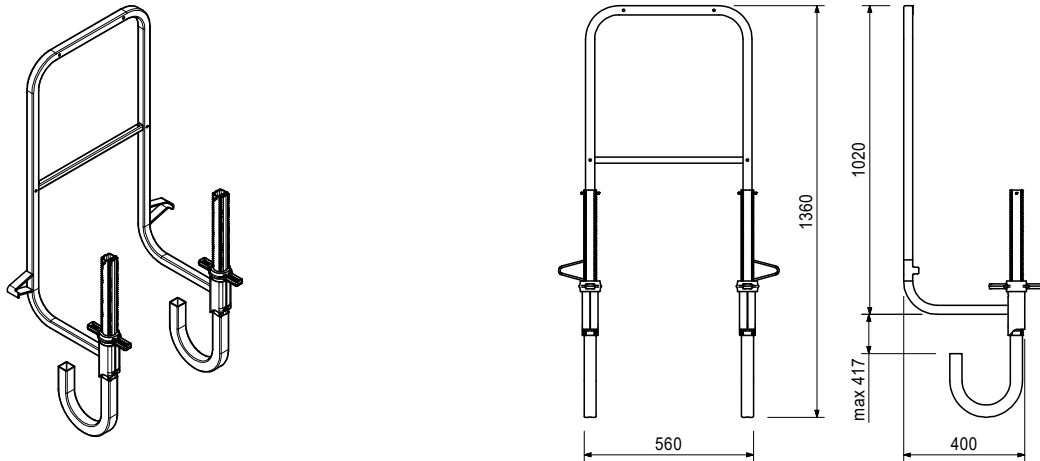

Art no. Weight [kg]

136622 1.450 **Multifunction Plate RCS**

For fixing the Guardrail Posts RCS and Scaffold Tubes Ø48,3mm to platform decks and decking girders.



Accessories General SB

Art no.	Weight [kg]	
114997	7.160	Bracing Shoe RCS DW15

For anchoring the bracing with DW15 to the building slab. Fixation with Anchor System M24 or corresponding dowels.

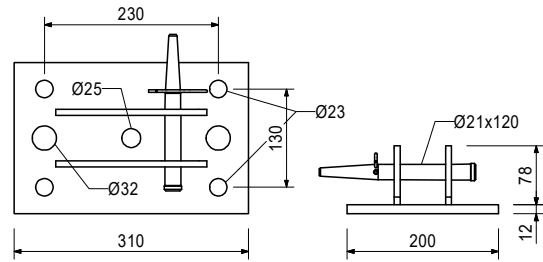
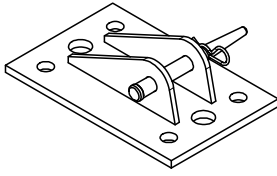

Consists of

- 1 pc 104031 Fitting Pin Ø21x120mm
- 1 pc 018060 Cotter Pin 4/1 ga

Art no.	Weight [kg]	
115378	1.080	Eye Nut RCS DW15

As an articulated connection to the Climbing Rail RCS, Steel Waler SRU for bracing with DW15.

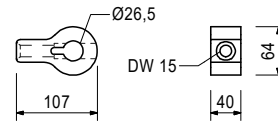

Accessory (not included)

104031	0.462	Fitting Pin Ø21x120mm
018060	0.014	Cotter Pin 4/1 ga
111567	0.729	Fitting Pin Ø26x120mm
022230	0.033	Cotter Pin 5/1 ga

Art no.	Weight [kg]	
126431	12.300	Hatch-2 RCS 55x60 foldable

Self-closing hatch for ladder access. Clear opening approx. 55x60cm. Ladder fixation with bolts or by hanging up.

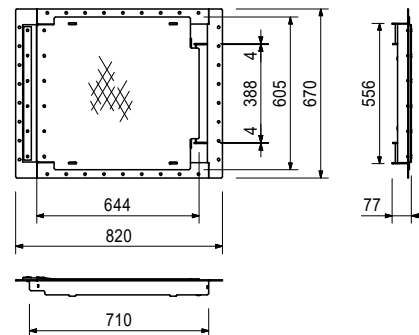
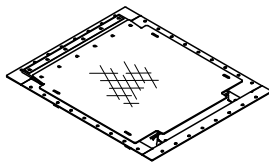

Accessory (not included)

024540	0.005	Wood-Screw 6x40 SK-TX30 HPI
710224	0.047	Screw ISO4017-M12x040-8.8-ga
710381	0.017	Hex-Nut ISO7040-M12-8-ga

Consists of

- 1 pc 126785 Hatch Hinge RCS
- 12 pc 108647 Rivet ISO15979-5.0x20-ST/ST
- 2 pc 022230 Cotter Pin 5/1 ga

Accessories General SB

Art no. Weight [kg]

051430 37.900 **Sliding Hatch**

Non self-closing hatch for ladder access. Clear opening approx. 73x55cm. Ladder fixation with bolts.

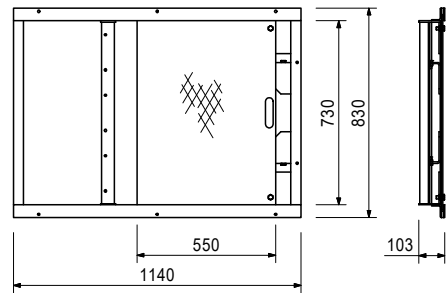
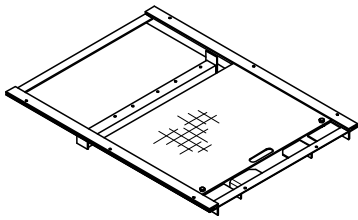

Accessory (not included)

024540 0.005 **Wood-Screw 6x40 SK-TX30 HPI**

Consists of

- 4 pc 710266 Screw ISO4017-M12x025-8.8-ga
- 4 pc 710381 Hex-Nut ISO7040-M12-8-ga

Art no. Weight [kg]

051410 11.700 **Ladder 180/6**

For accessing PERI Formwork Systems.

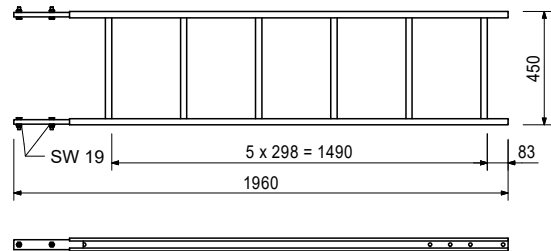
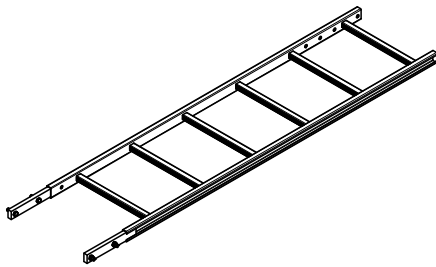

Consists of

- 4 pc 710224 Screw ISO4017-M12x040-8.8-ga
- 4 pc 710381 Hex-Nut ISO7040-M12-8-ga

Art no. Weight [kg]

051420 12.800 **Ladder 220/6**

As access for PERI Formwork Systems.

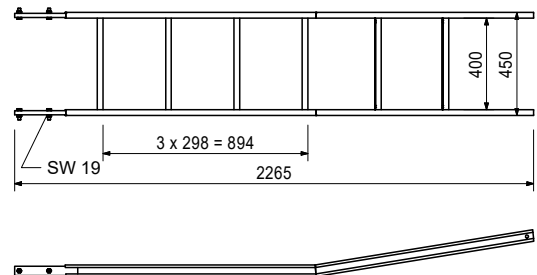
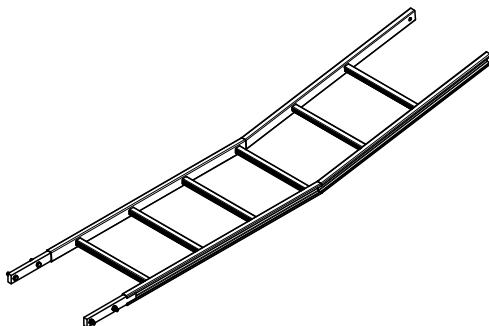

Consists of

- 4 pc 710224 Screw ISO4017-M12x040-8.8-ga
- 4 pc 710381 Hex-Nut ISO7040-M12-8-ga

Accessories General SB

Art no. Weight [kg]

103724 10.400 **End Ladder 180/2 cpl**

As access for PERI Formwork Systems.

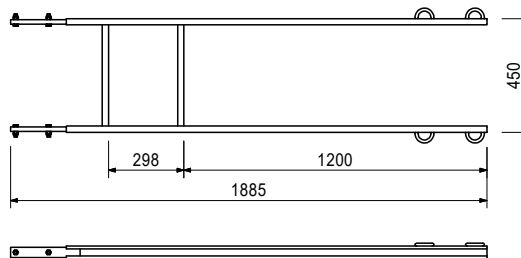
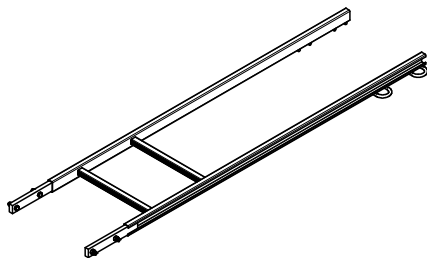

Consists of

- 4 pc 710224 Screw ISO4017-M12x040-8.8-ga
- 4 pc 710381 Hex-Nut ISO7040-M12-8-ga

Art no. Weight [kg]

109105 5.070 **Ladder Base 30 ga**

For horizontal fixing of ladders on the platform decking.

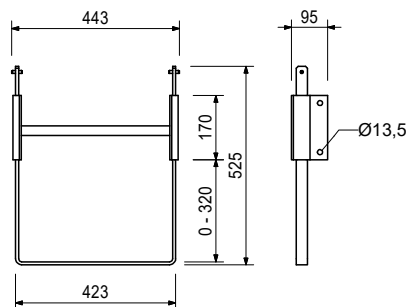
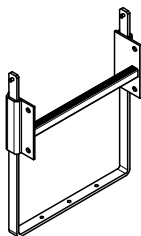

Art no. Weight [kg]

051460 2.180 **Ladder Base ga**

As bottom ladder connection and for securing ladders against sliding on the scaffold decks.

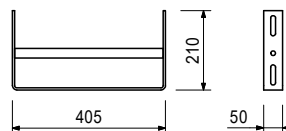
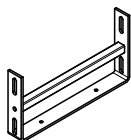

Art no. Weight [kg]

103718 0.684 **Ladder Hook**

For adjusting the bottom ladder. Always use in pairs.

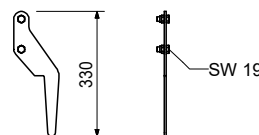

Consists of

- 2 pc 710266 Screw ISO4017-M12x025-8.8-ga
- 2 pc 710381 Hex-Nut ISO7040-M12-8-ga

Accessories General SB

Art no. Weight [kg]

Ladder Safety Cages

104132	15.600	Ladder Safety Cage 75
051450	25.200	Ladder Safety Cage 150

Ladder cage for PERI Ladder Access.

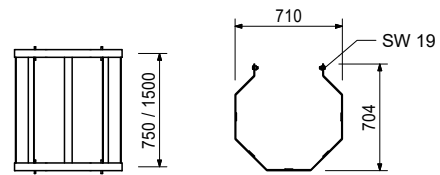
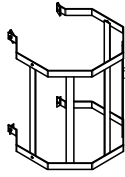

Consists of

- 4 pc 710266 Screw ISO4017-M12x025-8.8-ga
- 4 pc 701763 Clamping Plate FL 25x10x90mm

Art no. Weight [kg]

111165	6.260	Ladder Connector VARIO adj.
--------	-------	------------------------------------

For connecting ladders to Steel Walers SRZ and SRU Profile U100–U120.

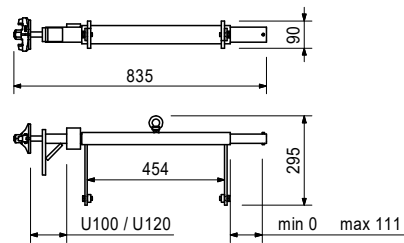
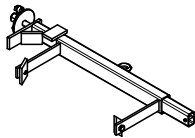

Consists of

- 2 pc 710266 Screw ISO4017-M12x025-8.8-ga
- 2 pc 701763 Clamping Plate FL 25x10x90mm

Art no. Weight [kg]

118463	0.181	Pin Ø16x90mm coat
--------	-------	--------------------------

For different connections. High strength.

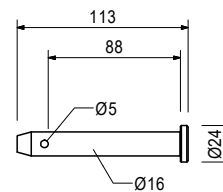
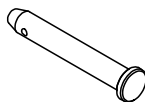

Art no. Weight [kg]

037160	0.736	Pin Ø20x205mm ga
--------	-------	-------------------------

For various connections.

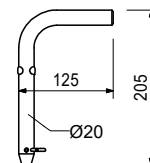
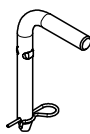

Consists of

- 1 pc 018060 Cotter Pin 4/1 ga

Accessories General SB

Art no.	Weight [kg]	
105400	0.330	Pin Ø20x140mm ga

For different connections.

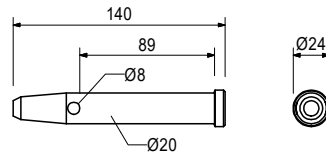
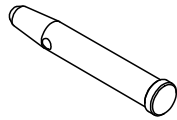

Accessory (not included)

018060	0.014	Cotter Pin 4/1 ga
--------	-------	--------------------------

Art no.	Weight [kg]	
715936	0.672	Pin with Clamping Sleeve

For different connections. High strength.

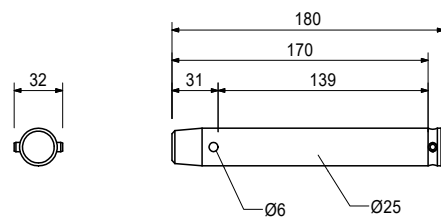
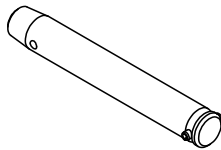

Art no.	Weight [kg]	
127400	1.490	Pin Ø40x160mm

For different connections.

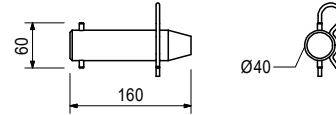
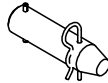

Art no.	Weight [kg]	
710545	3.150	Pin Ø50x150mm coat

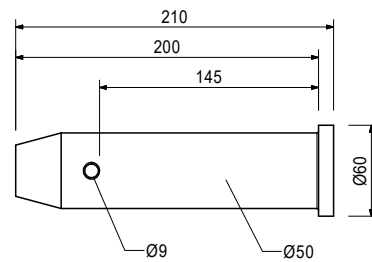
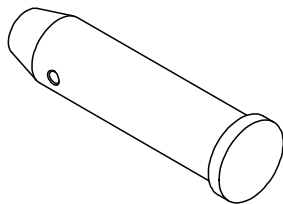

Art no.	Weight [kg]	
127397	2.660	Pin Ø50x175mm

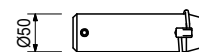
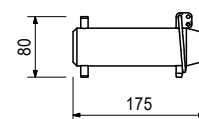
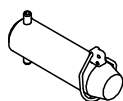

Accessories General SB

Art no. Weight [kg]

125355 3.850 **Pin VRB Ø50x250mm**

For connecting the Truss Girder VRB-Frames.

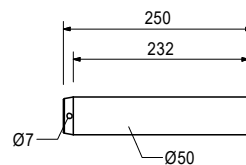
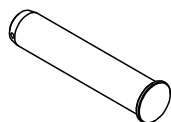

Accessory (not included)

125356 0.086 **Cotter Pin VRB 6/1**

Art no. Weight [kg]

130831 2.430 **Pin Hinge Connector RCS**

For different connections. High strength.

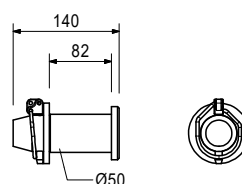

Art no. Weight [kg]

125349 0.351 **Fitting Pin VRB Ø21x105mm**

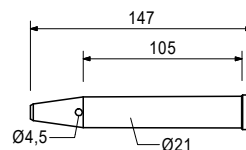
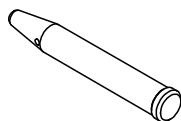

Accessory (not included)

018060 0.014 **Cotter Pin 4/1 ga**

Art no. Weight [kg]

104031 0.462 **Fitting Pin Ø21x120mm**

For different connections. High strength.

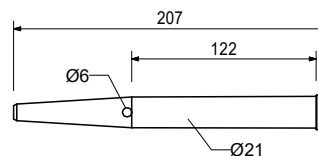
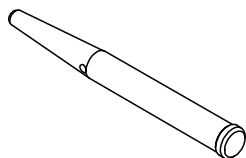

Accessory (not included)

018060 0.014 **Cotter Pin 4/1 ga**

Accessories General SB

Art no.	Weight [kg]	
125345	0.548	Fitting Pin VRB Ø26x105mm

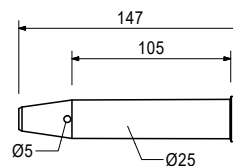
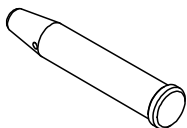

Accessory (not included)

18060	0.014	Cotter Pin 4/1 ga
-------	-------	--------------------------

Art no.	Weight [kg]	
111567	0.729	Fitting Pin Ø26x120mm

For different connections. High strength.

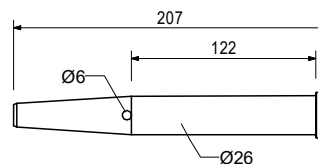
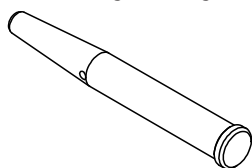

Accessory (not included)

018060	0.014	Cotter Pin 4/1 ga
--------	-------	--------------------------

Art no.	Weight [kg]	
132387	0.809	Fitting Pin Ø26x160mm ga

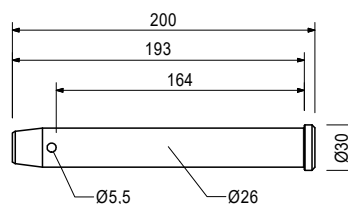
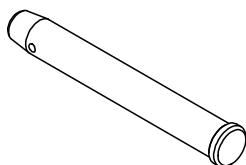

Art no.	Weight [kg]	
018060	0.014	Cotter Pin 4/1 ga

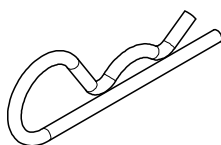

Art no.	Weight [kg]	
022230	0.033	Cotter Pin 5/1 ga



Accessories General SB

Art no.	Weight [kg]	
125356	0.086	Cotter Pin VRB 6/1

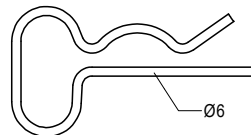
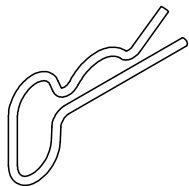

Art no.	Weight [kg]	
710618	0.098	Cotter Pin 8/1 coat

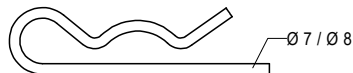
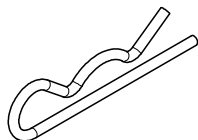

Art no.	Weight [kg]		L [mm]
Screws ISO4014-8.8-ga			
710285	0.050	Screw ISO4014-M08-100-8.8-ga	100
101949	0.015	Screw ISO4014-M08x030-8.8-ga	30
710220	0.087	Screw ISO4014-M12x080-8.8-ga	80
024900	0.255	Screw ISO4014-M20x080-8.8-ga	80
024910	0.303	Screw ISO4014-M20x080-8.8-ga	100
710226	0.340	Screw ISO4014-M20x090-8.8-ga	90
711078	0.360	Screw ISO4014-M20x130-8.8-ga	130
113766	0.518	Screw ISO4014-M20x180-8.8-ga	180

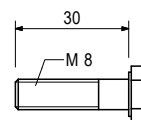
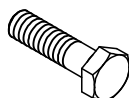

Art no.	Weight [kg]		L [mm]
070100	0.132	Screw ISO4016-M12x120-4.6-ga-N	120

For uses with small loads, including nut.

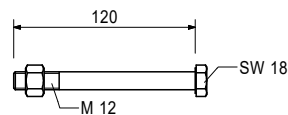
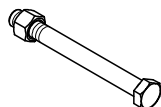

Accessories General SB

Art no.	Weight [kg]		L [mm]
Screws ISO4017-8.8-ga			
710224	0.047	Screw ISO4017-M12x040-8.8-ga	40
110598	0.142	Screw ISO4017-M12x140-8.8-ga	140
110599	0.242	Screw ISO4017-M12x240-8.8-ga	240
123844	0.130	Screw ISO4017-M20x035-8.8-ga	35
780357	0.178	Screw ISO4017-M20x050-8.8-ga	50
721912	0.244	Screw ISO4017-M20x070-8.8-ga	70
706480	0.214	Screw ISO4017-M24x030-8.8-ga	30
029420	0.590	Screw ISO4017-M30x070-8.8-ga	70
111759	0.760	Screw ISO4017-M30x090-8.8-ga	90

Alternative to leading screw M30, galvanized. Item number: 029450

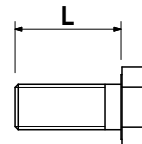
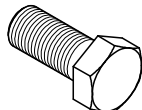

Art no.	Weight [kg]	
123843	0.623	Screw ISO4017-M30x080-10.9

For attaching Anchor Shoe H ACS and Anchor Shoe V ACS to Climbing Cone-2 M30/DW20 or Screw-On Cone M30/DW26.

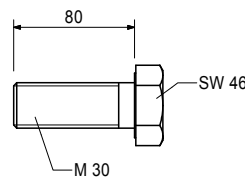
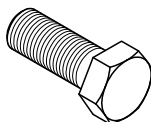

Art no.	Weight [kg]	
104526	0.017	Hex-Nut ISO4032-M12-8

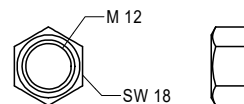

Art no.	Weight [kg]	
710330	0.017	Hex-Nut ISO4032-M12-8-ga

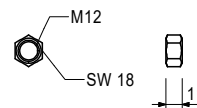

Art no.	Weight [kg]	
051759	0.050	Screw ISO1207-M06x030-4.8-ga

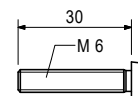
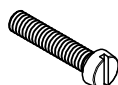

Accessories General SB

Art no.	Weight [kg]		L [mm]
113007	0.700	Screw ISO4762-M30x070-8.8-ga	70

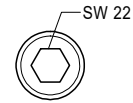
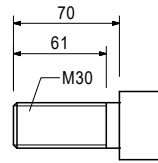
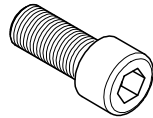

Art no.	Weight [kg]		
051728	0.800	Screw ISO4762-M30x110-10.9	

For attaching Climbing Shoe ACS, Climbing Shoe-2 ACS and Anchor Tube ACS right or left to Climbing Cone-2 M30/DW20 or Screw-On Cone M30/DW26

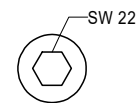
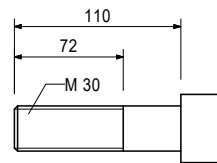
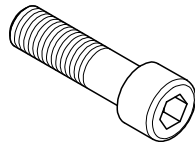

Art no.	Weight [kg]		
---------	-------------	--	--

Hex-Nuts ISO7040-ga

711071	0.004	Hex-Nut ISO7040-M08-8-ga
710381	0.017	Hex-Nut ISO7040-M12-8-ga
781053	0.065	Hex-Nut ISO7040-M20-8-ga

Self-locking.



Art no.	Weight [kg]		
130341	0.063	Hex-Nut ISO7042-M20-8-ga	

Self-locking.

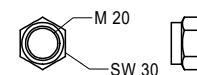

Art no.	Weight [kg]		
---------	-------------	--	--

Washers ISO7089-200HV-ga

706454	0.017	Washer ISO7089-20-200HV-ga
725574	0.009	Washer ISO7089-14-200HV-ga
780354	0.002	Washer ISO7089-08-200HV-ga



Art no.	Weight [kg]		
722356	0.002	Washer ISO7090-08-200HV	

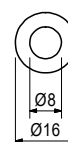

Accessories General SB

Art no. Weight [kg]

Washers ISO7093-1-200HV-ga

750350	0.027	Washer ISO7093-1-12-200HV-ga
710342	0.007	Washer ISO7093-1-08-200HV-ga

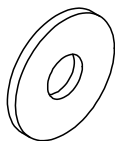

Art no. Weight [kg]

Washers ISO7094-100HV-ga

113819	0.368	Washer ISO7094-30-100HV-ga
129975	0.210	Washer ISO7094-24-100HV-ga
113350	0.174	Washer ISO7094-20-100HV-ga
113349	0.087	Washer ISO7094-16-100HV-ga
113348	0.043	Washer ISO7094-12-100HV-ga
125719	0.019	Washer ISO7094-10-100HV-ga
113347	0.013	Washer ISO7094-08-100HV-ga

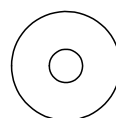

Art no. Weight [kg]

Wood-Screws SK-HPI

113806	0.002	Wood Screw 4.5x40 SK-TX20 HPI
103444	0.009	Wood Screw 8x37 SK-TX30 HPI
103443	0.036	Wood Screw 8x78 SK-TX30 HPI
024540	0.005	Wood-Screw 6x40 SK-TX30 HPI
024470	0.008	Wood-Screw 6x60 SK-TX30 HPI
024670	0.010	Wood-Screw 6x60 SK-TX30 HPI ma
110272	0.006	Wood-Screw 6x60 ZK-TX30 HPI
024690	0.008	Wood-Screw 6x80 SK-TX30 HPI
109790	0.008	Wood-Screw 8x35 SK-TX30 HPI
104892	0.010	Wood-Screw 8x44 SK-TX30 HPI
104647	0.013	Wood-Screw 8x58 SK-TX30 HPI

For Torx Bit Points TX30. Self-drilling.

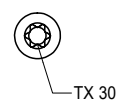
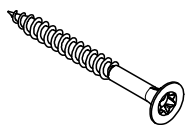

Art no. Weight [kg]

104911	0.013	Wood-Screw 6x100 RK-TX30 HPI
--------	-------	-------------------------------------

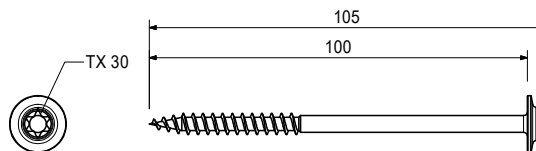
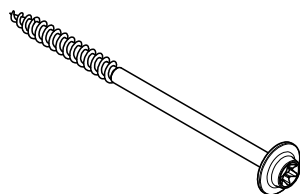

Accessories General SB

Art no.	Weight [kg]	
104912	0.011	Wood-Screw 6x80 RK-TX30 HPI

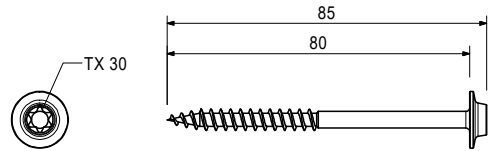
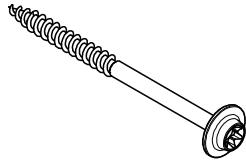

Art no.	Weight [kg]		L [mm]
024550	0.005	Wood-Screw 8x20 SK-TX30 HSX	20

For Torx blade TX30. Self-drilling.

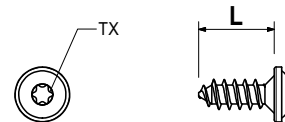

Art no.	Weight [kg]	
---------	-------------	--

Wood Screws SK HSX

102109	0.005	Wood Screw 3.5x45 SK-Z2 HSX
138247	0.005	Wood Screw 4x70 SK-TX20 HSX
138238	0.004	Wood Screw 5x25 SK-TX20 HSX
110642	0.006	Wood Screw 5x40 SK-TX20 HSX
138239	0.006	Wood Screw 6x60 SK-TX30 HSX
138240	0.006	Wood Screw 6x70 SK-TX30 HSX
138241	0.006	Wood Screw 6x80 SK-TX30 HSX
138242	0.006	Wood Screw 6x90 SK-TX30 HSX
024960	0.015	Wood Screw 6x120 SK-TX30 HSX
024970	0.017	Wood Screw 6x140 SK-TX30 HSX
024980	0.019	Wood Screw 6x160 SK-TX30 HSX
024990	0.021	Wood Screw 6x180 SK-TX30 HSX
111437	0.004	Wood-Screw 5x20 SK-TX25 HSX
105847	0.005	Wood-Screw 5x25 SK-Z2 HSX
024950	0.012	Wood-Screw 6x100 SK-TX30 HSX

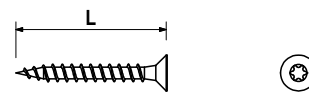
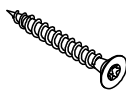

Art no.	Weight [kg]	
129711	0.010	Wood Screw 6x20 HRK-TX30 HSX

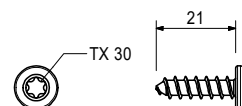

Accessories General SB

Art no.	Weight [kg]		L [mm]
138246	0.005	Wood Screw 8x50TK-TX40 HSX	54

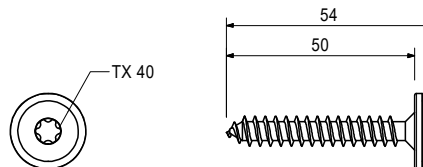
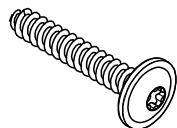

Art no.	Weight [kg]		L [mm]
Hex-Wood-Screws DIN571-ga			
029440	0.005	Hex-Wood-Screw 6x20 DIN571-ga	20
024270	0.023	Hex-Wood-Screw 8x60 DIN571-ga	60

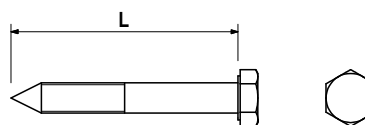
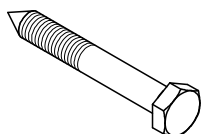

Art no.	Weight [kg]		B [mm]	L [mm]
Screws DIN603-M08-ga-Nu				
710295	0.028	Screw DIN603-M08x045-4.8-ga-Nu	22	45
710326	0.030	Screw DIN603-M08x060-4.8-ga-Nu	22	60
710709	0.036	Screw DIN603-M08x065-4.8-ga-Nu	22	65
710240	0.050	Screw DIN603-M08x100-4.8-ga-Nu	80	100
108834	0.085	Screw DIN603-M08x180-4.6-ga-Nu	28	180
024390	0.090	Screw DIN603-M08x200-4.8-ga-Nu	150	200

With nut.

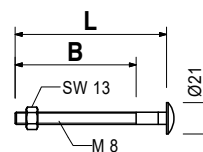

Art no.	Weight [kg]	
710312	0.005	Wire Nail 3.0x80mm

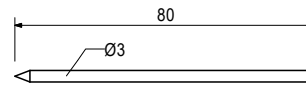
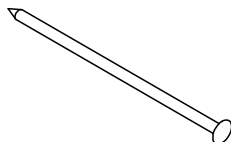

Art no.	Weight [kg]	
129157	0.017	Wire Nail 4.6x130mm

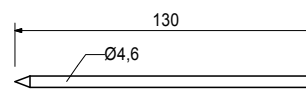
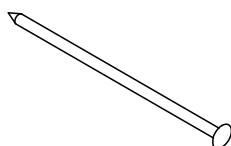

Accessories General SB

Art no.	Weight [kg]	
018280	1.000	Double Head Nail 65mm

Notes

Delivery unit: carton with 1000 pieces.

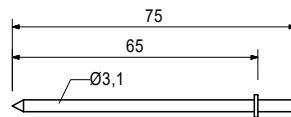
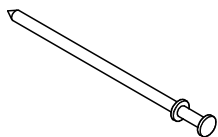

Art no.	Weight [kg]	
127320	158.000	Lifting Beam 9t

For moving climbing units.

Notes

Follow Instructions for Use.

Permissible load-bearing capacity 9t.

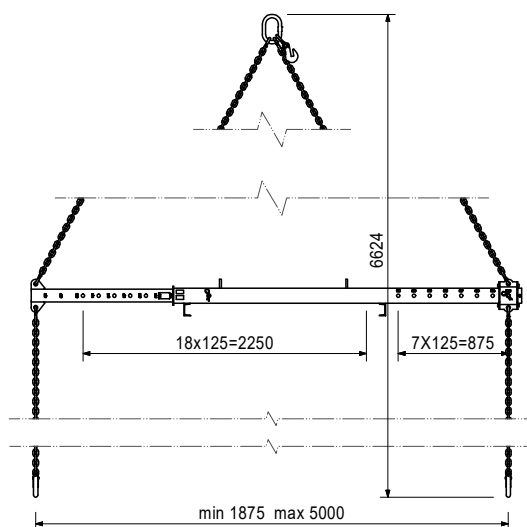
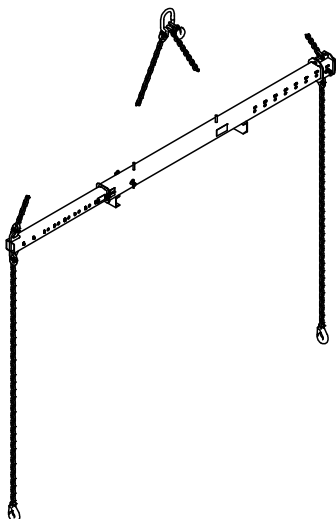

Consists of

- 1 pc 112865 Locking Pin Ø25x180mm coat
- 1 pc 022230 Cotter Pin 5/1 ga
- 1 pc 107297 Screw ISO4014-M12x140-8.8-ga
- 1 pc 710330 Hex-Nut ISO4032-M12-8-ga

Accessories General SB

Art no. Weight [kg]

070760 4.680 **Crane Splice GT 24**

For transporting elements by crane with the GT 24 Girder.

Notes

Follow Instructions for Use!

Permissible load-bearing capacity 700kg with crane sling angle $\leq 15^\circ$.

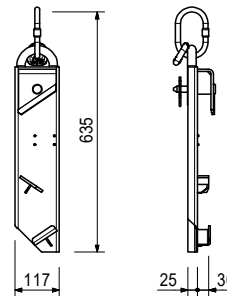
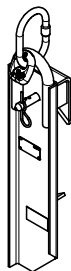

Consists of

1 pc 018050 Pin $\varnothing 16 \times 65/86$ mm ga

1 pc 018060 Cotter Pin 4/1 ga

Art no. Weight [kg]

111238 19.800 **Crane Splice GT 24 2t**

For transporting elements by crane with the GT 24 Girder. Adjustable from 230 to 410mm.

Notes

Follow Instructions for Use!

Permissible load-bearing capacity 2t with crane sling angle $\leq 30^\circ$.

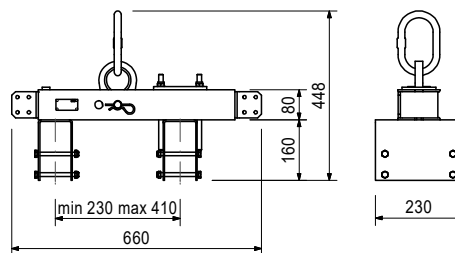
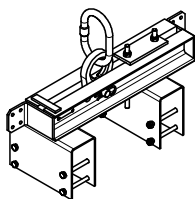

Consists of

1 pc 018060 Cotter Pin 4/1 ga

8 pc 710138 Screw ISO4014-M10x110-8.8-ga

8 pc 780356 Hex-Nut ISO7040-M10-8-ga

Art no. Weight [kg]

115168 6.950 **Lifting Hook MX 1.5t**

For transporting MAXIMO and TRIO Panels.

Notes

Follow Instructions for Use!

Permissible load-bearing capacity: Steel elements 1.5t. Alu elements 750kg.

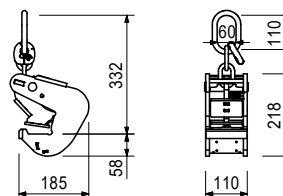
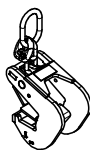

Accessories General SB

Art no. Weight [kg]

127834 2.210 **Lifting Eye-2 BR 2.5t ga**

As attachment point for moving climbing systems or Platform Beam BR.

Notes

Follow Instructions for Use!

Permissible load-bearing capacity 2.5t.

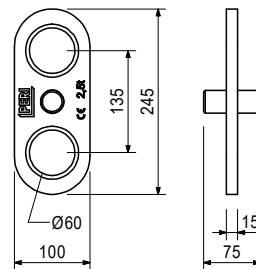

Accessory (not included)

020620

0.561

Spacer for BR

Art no. Weight [kg]

127821 0.957 **Crane Eye-2 CB 240 0.7t**

For assembly on the Climbing Bracket CB 240 when used as working scaffold.

Notes

Follow Instructions for Use!

Permissible load-bearing capacity 700kg.



Consists of

1 pc 128335 Screw ISO4014-M16x110 mach

1 pc 126248 Castle-Nut DIN935-M16-8-ga

1 pc 722825 Cotter Pin ISO1234-04.0x030-st

Art no. Weight [kg]

130616 0.670 **Shackle Ø16/Ø19mm 3.25t Hex-N.**

For attaching loads or mounting formwork elements, Trolleys HTP 2000kg by means of Turnbuckle CB Ø25-M20/DW15.

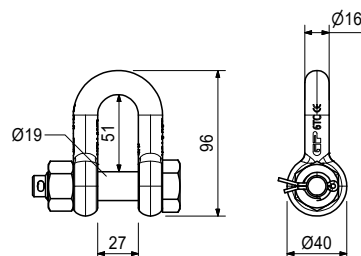
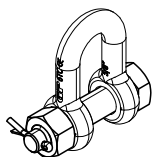

Accessories General SB

Art no.	Weight [kg]	
724812	0.656	Eyebolt M20x110mm coat

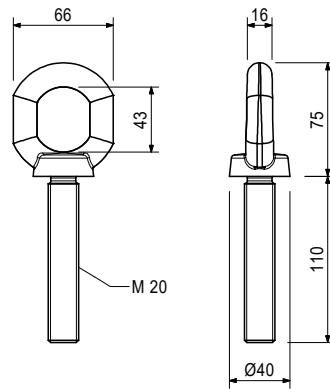
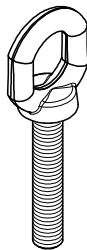

Accessory (not included)

781053	0.065	Hex-Nut ISO7040-M20-8-ga
113350	0.174	Washer ISO7094-20-100HV-ga

Accessories General SB

Art no.	Weight [kg]	
Tools ACS		
057281	0.042	Bit Clip for TX30
051777	1.650	Double Spanner Set 10-pcs.
051778	0.350	Double Spanner SW24/SW27
051763	0.125	Driftpin 10mm
057284	0.065	Drill Bit HSS 9mm long
057283	0.042	Drill Bit HSS 9mm short
051776	0.520	Extension 3/4" 200mm
057277	1.510	Open-End Wrench SW60
057282	0.500	Pipe Wrench
051764	2.650	Ratchet Wrench 3/4"
057278	0.405	Socket Set 8 Pieces
057279	0.260	Socket SW14
057280	0.430	Socket SW17
051765	0.235	Socket SW19 3/4"
051768	0.500	Socket SW22 3/4"
051766	0.215	Socket SW24 3/4"
057276	0.625	Socket SW30 3/4"
051767	0.660	Socket SW46 3/4"
051779	3.500	Tool Box 457x257x255mm
051761	13.700	Tool Set ACS
072140	0.005	Torx Bit TX30

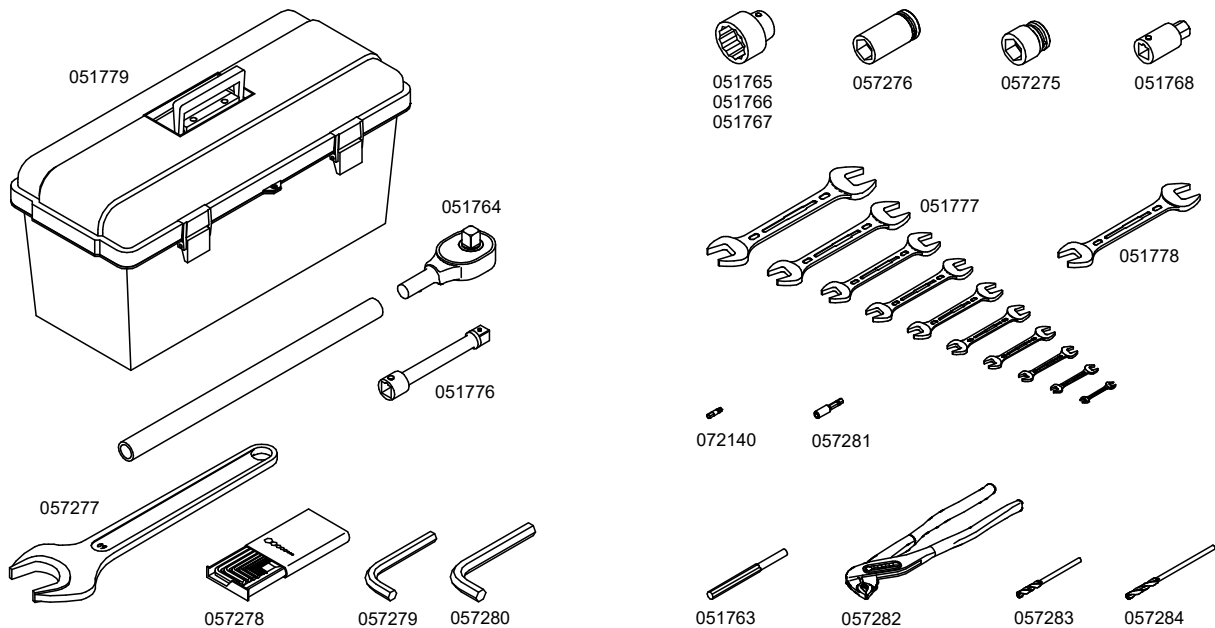

Art no.	Weight [kg]	
027212	0.445	Hexag. Recess Wrench SW14 long

Fits PERI Positioning Discs and Allen Key Bolts M16.



Accessories General SB

Art no.	Weight [kg]	
031490	1.890	Tens. Rod Spanner DW20/26 ga

For screwing out Tensio Anchors DW20 and DW26.

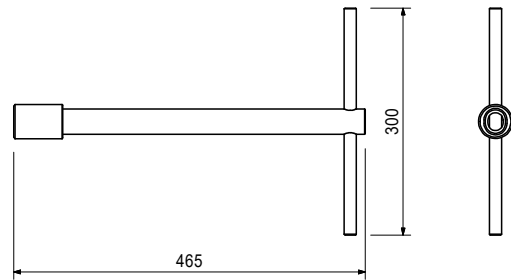
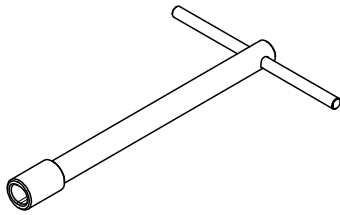

Art no.	Weight [kg]	
---------	-------------	--

Open-End Wrenches SW

138687	0.420	Open-End Wrench SW30
138686	0.446	Open-End Wrench SW36
027211	0.760	Open-End Wrench SW46 for SB
057277	1.510	Open-End Wrench SW60
027213	2.300	Open-End Wrench SW70
027210	3.300	Open-End Wrench SW80 for SB

For different applications.

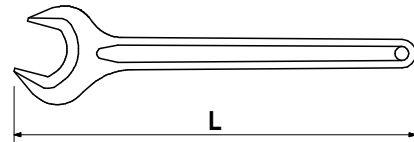
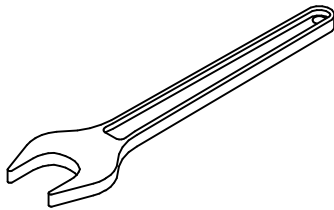

Art no.	Weight [kg]		L [mm]
---------	-------------	--	--------

Ratchet Wrenches

072180	0.560	Ratchet Wrench 1/2 "	300
029610	5.300	Ratchet Wrench 1 "	900
051764	2.650	Ratchet Wrench 3/4 "	630

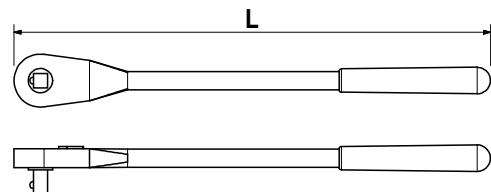
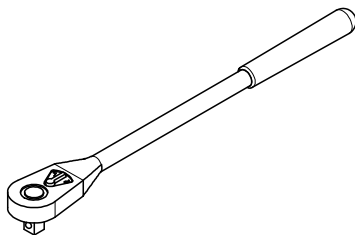

Art no.	Weight [kg]	
031480	2.460	Socket Wrench SW36 chromate

For various applications.

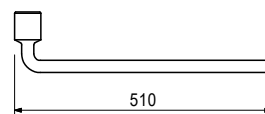
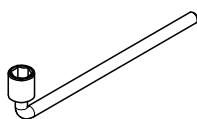

Accessories General SB

Art no. Weight [kg]

Sockets

029620	0.075	Socket SW19 1/2"
123751	0.216	Socket SW19 1/2"
104823	0.175	Socket SW30 1/2"
057276	0.625	Socket SW30 3/4"
102785	0.452	Socket SW36 3/4"
029630	0.580	Socket SW46 1"
029640	1.000	Socket SW55 1"

Fits to Hex. Bolts M12 or Height Adjusting Unit SW19.

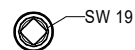

Art no. Weight [kg]

123750	0.776	Hexagon Socket SW27 1"
--------	-------	-------------------------------

Fits to Screw ISO4762-M36.

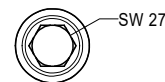
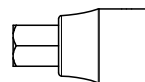
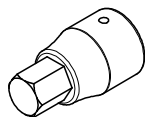

Art no. Weight [kg]

128601	1.280	Recovering Tool SW36
--------	-------	-----------------------------

For the installation of Heavy Duty Cones M36/DW26 - Ø108 by means of Ratchet Wrench 1" and Socket SW55 1"

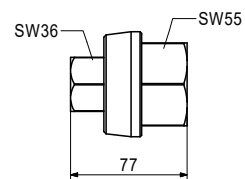
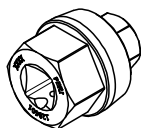

Art no. Weight [kg]

021790	1.000	Combi Ratchet Spanner SW24
--------	-------	-----------------------------------

For adjusting RUNDIFLEX Panels and Cantilevered Parapet Platform GKB.

Notes

Length approx. 500mm.

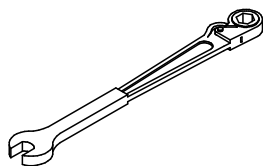

Accessories General SB

Art no. Weight [kg]

030460 60.000 **Pretension Jack for DW15/20/26**

For pre-tensioning tie rods, pulling out tie rods embedded in the concrete and for clean connecting surfaces at concrete joints. Complete in metal box.

Notes

Follow Instructions for Use!
Maximum tensile force 300kN.

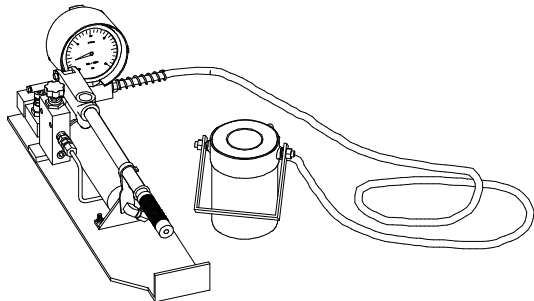

Consists of

1 pc 030663 Adapter-I f. Pretension Jack
1 pc 030664 Adapter-III f. Pretension Jack

Accessories General SB

Art no.	Weight [kg]	
115581	10.280	Service Box Hydraulics

Consisting of:

- 1 pc. 115590 Tool Box 580x260x285mm
- 6 pc. 115583 Pressure Gauge Typ 570 VA-Geh.
- 6 pc. 115584 Hose MKT 6-02 DN 02
- 12 pc. 115582 Measuring Coupl. SMK 20-G 1/4-PC
- 2 pc. 115591 Double Spanner SW10x13
- 1 pc. 115592 Double Spanner SW13x17
- 1 pc. 135172 Double Spanner SW19x22
- 1 pc. 115588 Double Spanner SW19x24
- 1 pc. 051778 Double Spanner SW24x27
- 1 pc. 115589 Double Spanner SW27x32
- 1 pc. 057278 Allen Key Set 8 pcs.
- 1 pc. 115585 Allen Key SW12
- 1 pc. 057279 Allen Key SW14
- 1 pc. 057282 Pipe Wrench
- 1 pc. 115147 Angle Fitting Set PS
- 2 pc. 115396 Fitting Set PS RCS short
- 1 pc. 072180 Ratchet Wrench 1/2"
- 20 pc. 123881 Tube Screw Plug ROV12SX
- 20 pc. 123880 Threaded Plug VKAN 12S VIT
- 100 pc. 051760 Cable Binder NT-240H
- 2 pc. 126425 Distance Piece Ø120mm coat
- 1 pc. 126440 Socket SW17 1/2"
- 1 pc. 135173 Allen Key SHR-Bit SW05
- 1 pc. 135174 Allen Key SHR-Bit SW06
- 1 pc. 135175 Allen Key SHR-Bit SW08
- 1 pc. 135176 Allen Key SHR-Bit SW10
- 1 pc. 135177 SHR Screwdriver Bit 6 parts Slot/PH
- 2 pc. 711035 PERI Label 128x65mm
- 1 pc. 126434 List of contents Hydraulic Service Case

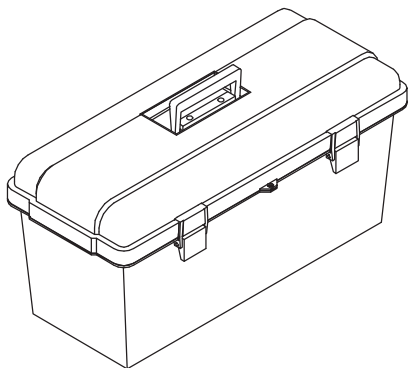

Art no.	Weight [kg]	
133372	6.800	Cordless Screwdriver-Set ACS

Consists of

- 1 pc 111435 Socket SW17 1/2"
- 1 pc 133356 Screwdriver ACS 18V
- 1 pc 133369 Extension 125mm 1/2"
- 1 pc 133370 Adaptor 1/4" to C6.3 hex.
- 1 pc 133371 Adaptor 1/4" on 1/2"

Accessories General SB

Art no.	Weight [kg]	
138813	1.000	Torque Wrench 40-200Nm

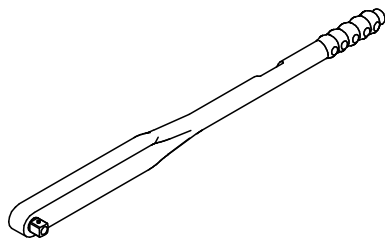

Art no.	Weight [kg]	
057090	6.700	Torque Wrench 140-760Nm

Notes

Outer square 3/4"
length: 812mm
incl. sheet metal case

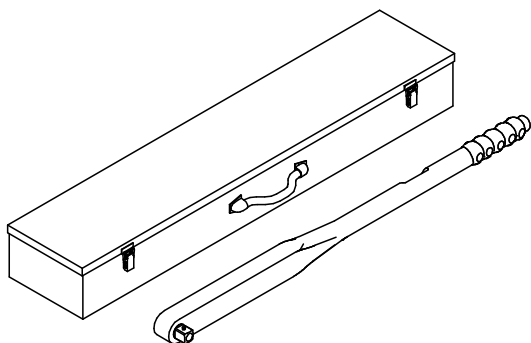

Art no.	Weight [kg]	
065068	88.200	Grate Pallet 80x120 ga

For stacking and transportation of formwork and scaffold components.

Notes

Follow Instructions for Use!
Capacity approx. 0.75m³.
Load-carrying capacity 1.5t.

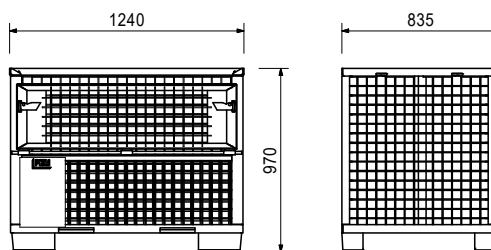
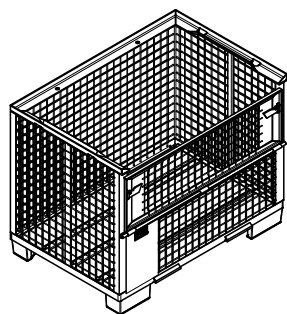

Accessories General SB

Art no. Weight [kg]

065067 9.410 **Lid for Grate Pallet 80x120**

For closing Crate Pallets 80x120 or Hardware Boxes 80x120.

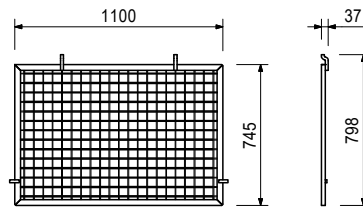
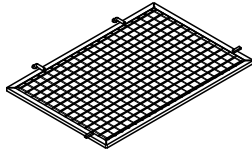

Art no. Weight [kg]

025660 66.500 **Hardware Box 80x120 ga**

For stacking and transportation of formwork and scaffold components.

Notes

Follow Instructions for Use!

Capacity approx. 0.28m³.

Permissible load-bearing capacity 1.5t.

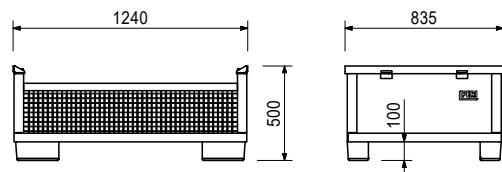
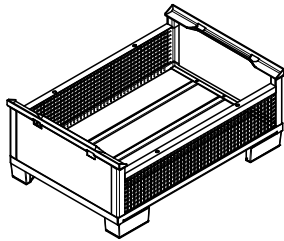

Art no. Weight [kg]

L [mm]

Pallets RP-2

103434 38.500 **Pallet RP 80x120/2 ga**

1200

103429 45.300 **Pallet RP 80x150/2 ga**

1500

For stacking and transportation of formwork and scaffolding components.

Notes

Follow Instructions for Use!

Permissible load-bearing capacity 1.5t.

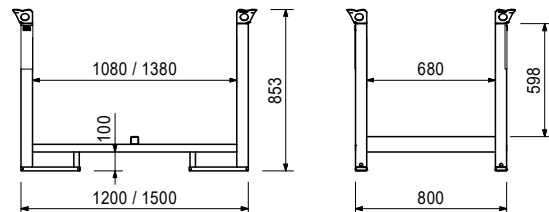
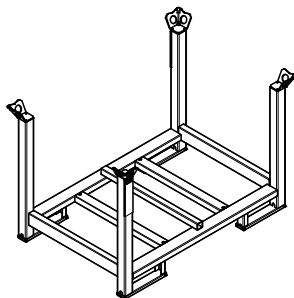

Art no. Weight [kg]

065015 28.000 **Euro Flat Pallet 80x120**

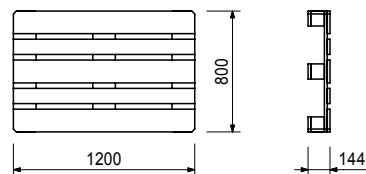
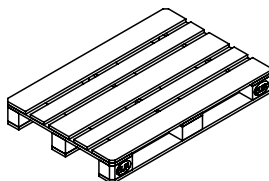

Accessories General SB

Art no. Weight [kg]

061510 105.000 **Pallet Lifting Trolley 1800mm**

For moving pallets and crate pallets.

Notes

Follow Instructions for Use!

Forklift arm length 1800mm, forklift arm width 550mm, stroke range 115mm.

Permissible load-bearing capacity 2t.

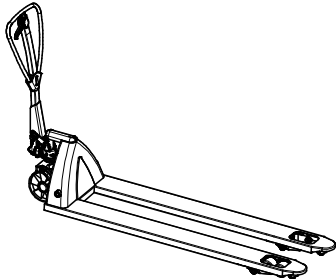

The optimal system
for every project and
any requirement



Wall formwork



Column formwork



Slab formwork



Climbing systems



Bridge formwork



Tunnel formwork



Shoring



Working scaffolds for construction



Working scaffolds for facades



Working scaffolds for industry



Access



Safety scaffolds



Safety systems



System-independent accessories



Services



PERI Danmark A/S
Forskalling & Stilladssystemer
Greve Main 26
2670 Greve
Tlf. +45 4345.3627
peri@peri.dk
www.peri.dk

