

# DUO

## Lightweight System Hand-set Formwork

Instructions for Assembly and Use – Standard Configuration – Issue 2.0

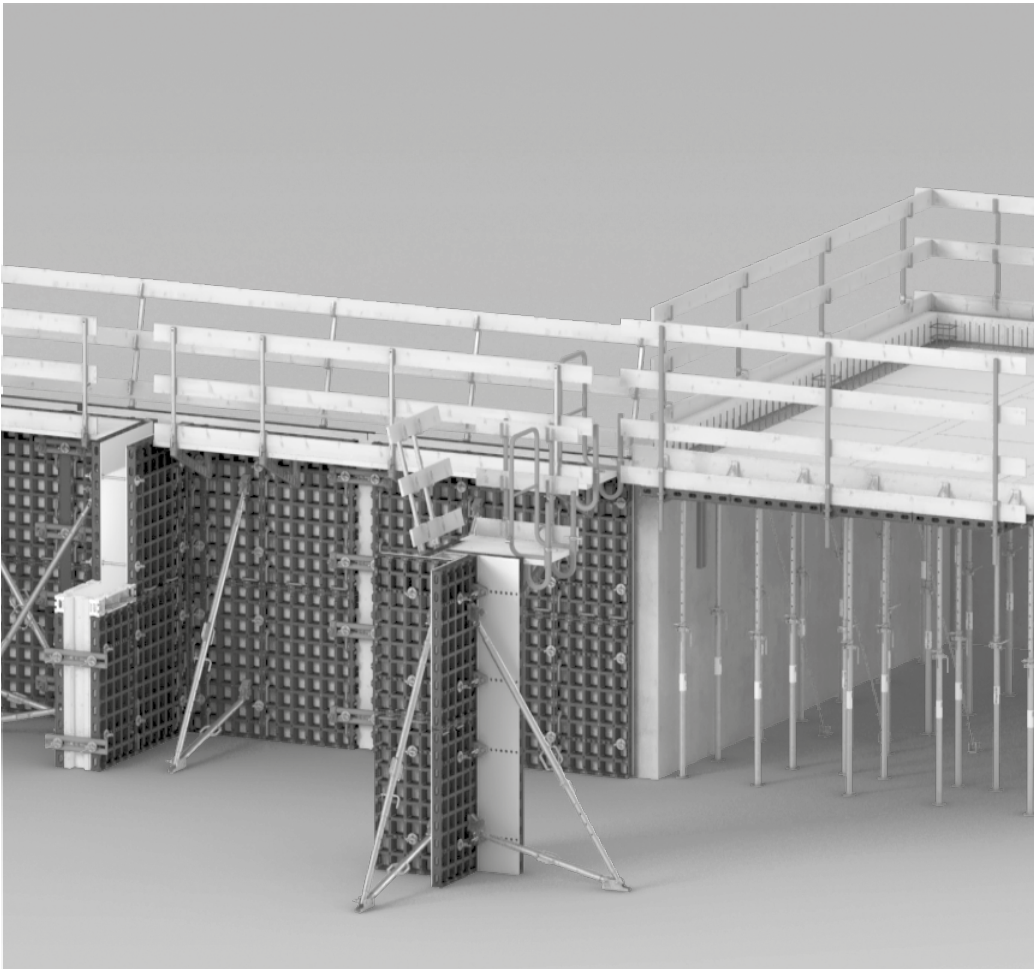

## Overview

Main components	4
Key	5
Notes on illustrations	5

## Introduction

Target groups	6
Intended use	7
RFID transponder	7
Disposal	7
Cleaning and maintenance instructions	8
Additional technical documentation	9
Scope	9
Identification marking	9
Instructions for use	9

## Safety instructions

Cross-system	10
System-specific	12

## Storage and transportation

A1 Storage and transportation	14
A2 Panel	18
Panel overview	18
DP panel	19
DMP multi panel	20
DFP filler panel	21
A3 Panel connections	22
Tools	22
DUO couplers	22
DUO coupling ties	25
DUO corner ties	26
DUO corner connectors	27
DUO tube holders	28
DUO 62 compensation walers	29
DUO timber connector	31
DUO frame holders	34
A4 Additional accessories	35
DES extension supports	35
DUO stripping levers	36
DUO Crane Eyes	39

## Wall formwork

B1 Wall formwork	40
Assembly without a crane	42
Assembly with a crane	45
LIWA DUO adapter	48
Layout of the LIWA LRS locks (using LIWA DUO adapters)	50
DOMINO DUO adapters	52
Layout of the DOMINO DRS locks (using DOMINO DUO adapters)	53
DUO SB hook straps	56
B2 Anchor technology	60
B3 Push-pull props	61
DUO brace connectors	61
Push-pull props and kicker braces	61
Table of PERI push-pull props and kicker braces	62

B4 Working and concreting scaffolds	64
DUO scaffold brackets	64
DUO front post holders	65
Assembly at internal corners	68
Assembly in case of height extensions	69
B5 Corners	70
DC corner posts	70
90° corners	72
Corner panels	74
Height extensions using DP 60 panels	76
Height extensions using filler panels	78
Alternative formwork for external corners	80
B6 T-junctions, wall connections	81
Obtuse-angle wall connection	82
B7 Wall offsets	83
B8 Length compensation	88
B9 Stopped formwork	92
B10 Height extensions	96
Height offset	96
Height extensions using DP 135 panels	97
Height extensions using DP 60 panels	98
Height extensions with DFP filler panels	98
Extensions with DES extension support	100
B11 Foundations	101
Foundation formwork with DP panels	101
Foundation formwork with DMP multi panels	102
Foundation formwork with DP 60 panels	103
Foundation formwork with DUO frame holder	104
Foundation formwork with DUO foundation tie clamp	105

## Column formwork

C1 Column formwork	106
Overview	106
Column formwork with DUO DMP multi panels	107
Assembly without a crane	108
Striking without a crane	110
Striking with a crane	111
DUO steel waler connectors	112
C2 Shear walls	114
Cross-sections	114
DUO attachment parts and couplers	116
Striking	117

## Slab formwork

D1 System components	120
Overview	120
Safety instructions	121
Propheads	122
Layout of DFH propheads	123
Layout of DBH backpropping heads	123
Slab props	123
DUO shuttering aids	124
DUO 82 wall holders	125
DUO prop adapters	126
D2 Shuttering	128
General	128

DFH system propheads	129
DBH system backpropping heads	133
D3 Length compensations	136
Wall compensations	136
Compensations around columns	138
Backpropped slab - compensations around columns	140
D4 Cantilevers, guardrails	141
Cantilevers with DFH propheads	141
Cantilevers with DBH backpropping heads	143
D5 Striking	145
DFH system propheads	145
DBH system backpropping heads	146
D6 Slab formwork with DUO carrier racks	148
Additional system components	148
Shuttering	151
Striking	158
<b>Cleaning and maintenance</b>	
E1 Cleaning and maintenance	160
Foreword	160
Cleaning instructions	161
DUO cleaning device and	
DUO shuttering aid	162
Replacing the formlining	163
<b>Tables</b>	
F1 Tables	164
DUO slab with DFH prophead	164
DUO slab with DBH backpropping head	165
<b>Product overview</b>	
DUO	166

## Main components

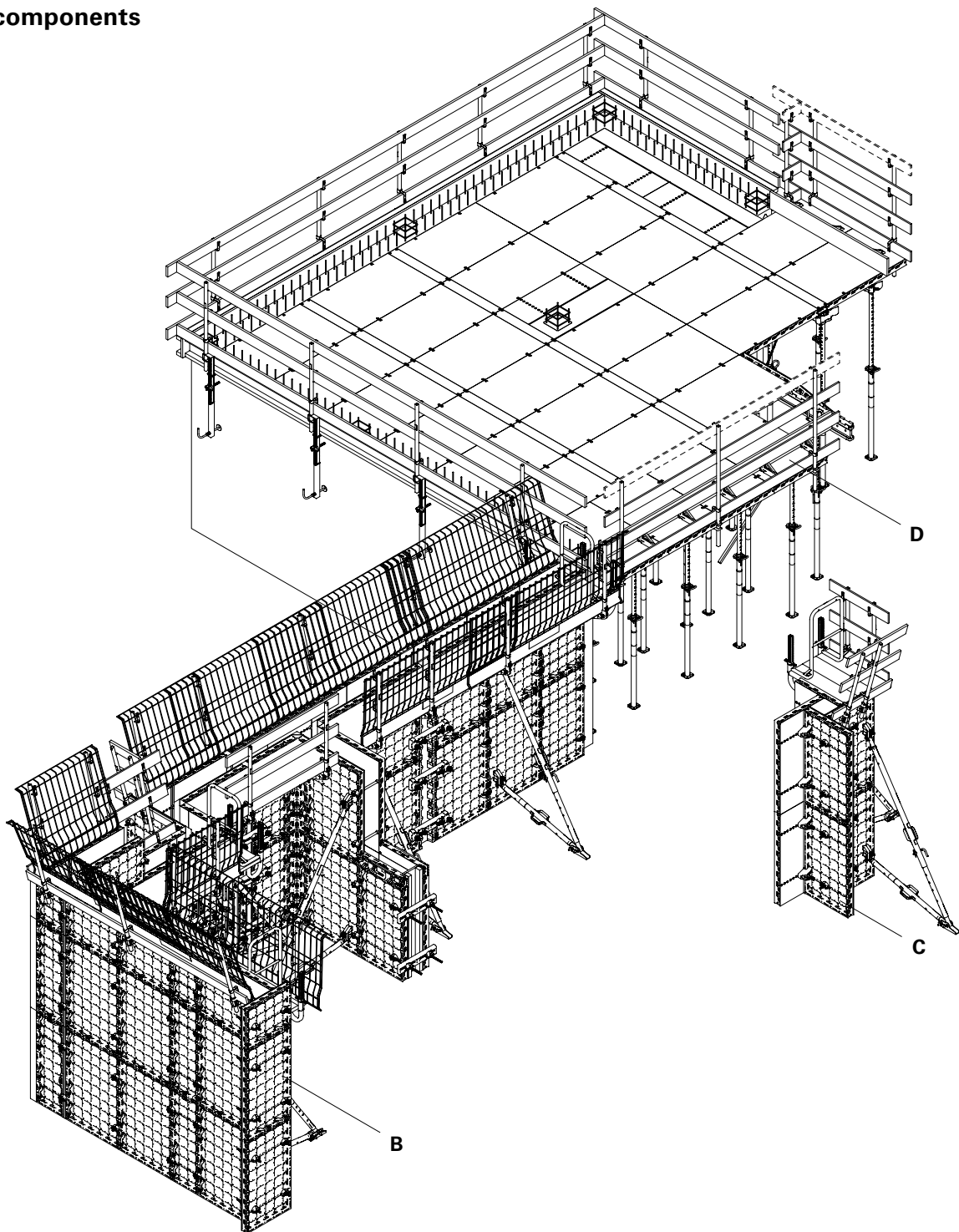

## Section

- B Wall formwork
- C Column formwork
- D Slab formwork

## Key

### Pictogram | Definition

 Danger / Warning / Caution

 Note

 To be complied with

 Load-bearing point

 Visual check

 Tip

 Incorrect use

 Safety helmet

 Safety shoes

 Safety gloves

 Safety goggles

 Personal protective equipment to prevent falling from a height (PPE)

### Arrows

 Arrow representing an action

 Arrow representing a reaction of an action\*

 Arrow representing forces

\* If not identical to the action arrow.

### Safety instruction categories

The safety instructions alert site personnel to the risks involved and provide information on how to avoid these risks. Safety instructions are featured at the beginning of the section or ahead of the instructions, and are highlighted as follows:

#### **Danger**

This sign indicates an extremely hazardous situation which, if not avoided, will result in death or serious, irreversible injury.

#### **Warning**

This sign indicates a hazardous situation which, if not avoided, could result in death or serious, irreversible injury.

#### **Caution**

This sign indicates a hazardous situation which, if not avoided, could result in minor or moderate injury.

#### **Note**

This sign indicates situations in which failure to observe the information can result in material damage.

### Format of the safety instructions

#### **Signal word**

Type and source of hazard!  
Consequences of non-compliance.  
⇒ Preventative measures.

### Dimensions

Dimensions are usually given in cm. Other measurement units, e.g. m, are shown in the illustrations.

### Conventions

- Instructions are numbered with: 1. ...., 2. ...., 3. ....
- The result of an instruction is shown by: →
- Position numbers are clearly provided for the individual components and are given in the drawing, e.g. **1**, in the text in brackets, for example **(1)**.
- Multiple position numbers, i.e. alternative components, are represented with a slash: e.g. **1/2**.

### Notes on illustrations

The illustration on the front cover of these instructions is understood to be a system representation only. The assembly steps presented in these Instructions for Assembly and Use are shown in the form of examples with only one component size. They are valid for all component sizes contained in the standard configuration.

To facilitate understanding, detailed illustrations are sometimes incomplete. The safety installations which have possibly not been shown in these detailed illustrations must nevertheless be available.

## Target groups

### Contractors

These Instructions for Assembly and Use are designed for contractors who either

- assemble, modify and dismantle the formwork systems, or
- use them, e.g. for concreting, or
- allow it to be used, e.g. for forming operations.

The contractor's procedures for the control of temporary works ensure that suitably competent persons are appointed to manage the planning and use of PERI formwork systems.

The appointed person(s):

- must identify potential hazards during the planning phase,
- determines measures that provide protection against risks,
- creates a safety and health protection plan,
- coordinates the protective measures for the contractor and site personnel so that they do not endanger each other,
- monitors compliance with the protective measures.

### Competent person

- is appointed by the contractor,
- must be on site for all system operations,
- prepares and updates the plan for assembly, modification and dismantling,
- prepares and updates the plan for use of the system by the user,
- supervises the assembly, modification and dismantling work (supervisor).

### Competent persons qualified to carry out inspections

Due to the specialist knowledge gained from professional training, work experience and recent professional activity, the competent person qualified to carry out inspections has a reliable understanding of safety-related issues and can carry out inspections correctly. Depending on the complexity of the inspection to be undertaken, e.g. scope of testing, type of testing or the use of certain measuring devices, a range of specialist knowledge is necessary.

### Qualified personnel

PERI systems may only be assembled, modified or dismantled by personnel who are suitably qualified to do so. Qualified personnel must have completed a course of training\* in the work to be performed, covering the following points at least:

- Explanation of the plan for the assembly, modification or dismantling of the formwork in an understandable form and language.
- Description of the measures for safety assembling, modifying or dismantling the formwork.

- Naming of the preventive measures to be taken to avoid the risk of persons and objects falling.
- Designation of the safety precautions in the event of changing weather conditions which could adversely affect the safety of the formwork system as well as the persons concerned.
- Details regarding permissible loads.
- Description of all other risks and dangers associated with assembly, modification or dismantling operations.



- **Ensure that the respective current version of relevant national guidelines and regulations are complied with!**

\* Instructions are given by the contractor himself or a competent person selected by him.

## Intended use

### Product description

PERI products have been designed for exclusive use in the industrial and commercial sectors only by suitably trained personnel.

PERI DUO is a lightweight hand-set formwork system made of technopolymer. It is suitable for wall, slab, column and foundation formwork.

The standard configuration includes:

- Formwork for vertical walls up to 5.40 m high, with wall thicknesses from 15 cm to 40 cm.
- Slab formwork can be realised up to a slab thickness of 30 cm.
- Columns can be formed in cross sections from 15 cm to 55 cm, in 5 cm increments.

The system accessories are platform brackets, brace connector, crane eye, wall thickness compensator and corner connector for all vertical applications. Propheads and slab guardrail holders are available for horizontal applications.

### Criteria

The main components are made of technopolymer, a 100% recyclable material.

It is resistant to all environmental influences occurring on the construction site.

It does not form rust or rot, it neither shrinks nor swells as a result of moisture absorption.

The system is assembled without a hammer. Therefore, assembly is quick and quiet.

### Technical data

Panel heights: 135, 60 cm

Panel widths: 90, 75, 60, 45, 30, 15 cm

Wall thickness compensations:

5, 6, 7, 8, 9, 10 cm

Internal, external corner: 10 x 10 cm

Permissible temperature range for use, cleaning, storage and transportation: -20 °C – +60 °C.

For walls:

Max. perm. fresh concrete pressure 50 kN/m<sup>2</sup> according to DIN 18218, evenness according to DIN 18202, table 3, line 6.

For columns and shear walls:

Max. perm. fresh concrete pressure 80 kN/m<sup>2</sup> according to DIN 18218, evenness according to DIN 18202, table 3, line 6.

For slabs:

Max. permissible slab thickness 30 cm according to DIN EN 12812, evenness according to DIN 18202, table 3, line 6.

For permissible prop loads, see PERI Design Tables.

DUO crane eyes: Load-carrying capacity 200 kg.

## Cleaning and maintenance instructions

In order to maintain the value and operational readiness of the formwork materials over the long term, clean the panels after each use.

Some repair work may also be inevitable due to the tough working conditions. The following points should help to keep cleaning and maintenance costs as low as possible.



The contractor must ensure that the personal protective equipment required for cleaning, maintenance and repair work such as

- Safety helmet,
- Safety shoes,
- Safety gloves,
- Safety goggles,

is available and used as intended.

Cleaning tools must be adapted to the respective surfaces of the components so that they are not damaged.

The use of diesel or kerosene as a concrete release agent is not recommended as it negatively affects the surface of the formwork panels.

Spray the formwork on both sides with concrete release agent before each use; this facilitates easier and faster cleaning of the formwork. Spray the concrete release agent very thinly and evenly!

Do not spray work platforms and walkways with concrete release agent. Risk of slipping.

Spray the rear side of the formwork with water immediately after concreting; this avoids any time-consuming and costly cleaning operations.

When used continuously, spray the panel formlining with concrete release agent immediately after striking; then clean by means of a scraper, brush or rubber lip scraper. Important: Do not clean formlining made of plywood with high-pressure equipment. This could result in the formlining being damaged.

Fix box-outs and mounting parts with double-headed nails; as a result, the nails can easily be removed later, and damage to the formlining is largely avoided.

Close all unused tie holes with plugs; this eliminates any subsequent cleaning or repair work. Tie holes accidentally blocked with concrete are cleared by means of a steel pin from the formlining side.

When placing bundles of reinforcement bars or other heavy objects on horizontally stored formwork elements, suitable support, e.g. square timbers, is to be used: this prevents impressions and damage to the formlining to a large extent.

Internal concrete vibrators should be fitted with rubber caps if possible; as a result, any damage to the formlining is reduced if the vibrator is accidentally inserted between the reinforcement and formlining.

Never clean powder-coated components, e.g. elements and accessories, with a steel brush or hard metal scraper; this ensures that the powder-coating remains intact.

Use spacers for reinforcement with large-sized supports or extensive areas of support; this largely avoids impressions being formed in the formlining when under load.

Mechanical components, e.g. spindles or gear mechanisms, must be cleaned of dirt or concrete residue before and after use, and then greased with a suitable lubricant.

Provide suitable support for the components during cleaning so that no unintentional change in their position is possible.

Do not clean components suspended on crane lifting gear.

## Additional technical documentation

- DUO posters
- Instructions for Assembly and Use:
  - PERI UP Flex Shoring Tower
  - PEP Ergo, PEP 10, PEP 20, PEP 30 Slab Props
  - PEP Alpha-2 Slab Props
- Instructions for Use:
  - DUO Crane Eyes
  - DUO Stacking Devices
  - ASW 465 Stripping Carts
  - Alu-2 Stripping Carts
  - PERI Pallets and Stacking Devices
  - PERI Pallet Lifting Trucks
  - DUO repair kits
- Type tests
  - MULTIPROP Individual Props
  - MULTIPROP Systems
  - MULTIPROP Individual Props with MP 50 Base
  - MULTIPROP System with MP 50 Base
- Brochure: DUO
- User info: Plastic Stopend Angle
- DUO Component Design Data



## Scope

These Instructions for Assembly and Use are only valid outside the legal domain of the Federal Republic of Germany.

For use in the FRG, only the Instructions for Assembly and Use for "DUO Lightweight System Hand-Set Formwork for the Federal Republic of Germany" are approved for use.

## Instructions for use

Use in a way not intended, deviating from the standard configuration or the intended use according to the Instructions for Assembly and Use, represents a misapplication with a potential safety risk, e.g. risk of falling.

Only PERI original components may be used. The use of other products and spare parts is not allowed.

Changes to PERI components are not permitted.

The system described in these Instructions for Assembly and Use may contain patent-protected components.

## Identification marking

The anticipated period of usability is 10 years. The technical characteristics are guaranteed for the period of usability. The period of usability is checked by means of the engraved production date. If the period of usability is exceeded, it is advisable to replace the component.

The production date is engraved on both front sides of the panels.

### Example

Produced in November 2019 - component can be used until October 2029.

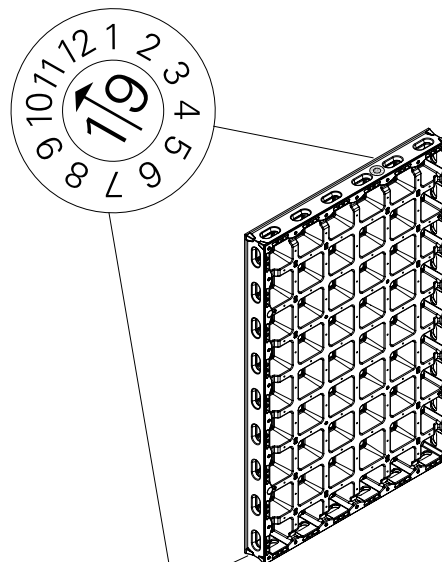

## Recurring inspections and use

The system components must be checked by the contractor and the proper condition ascertained. During this process, the period of usability must be checked above all else.

The components must be free of damage (especially cracks).

The components may only be used if the material is in good condition.

## Cross-system



### Safety instructions apply to all service life phases of the system.

#### General

The contractor must ensure that the Instructions for Assembly and Use supplied by PERI are available at all times and understood by the site personnel.

These Instructions for Assembly and Use can be used as the basis for the site based Risk Assessment and Method Statement (RAMS) compiled by the contractor. They are not to be considered as a substitute for the RAMS.

Refer to and comply with the safety instructions and permissible loads.

For the application and inspection of PERI products, the current safety regulations and guidelines valid in the respective countries must be observed.

Materials and working areas are to be inspected on a regular basis, especially before each use and assembly, for:

- damage,
- stability and
- functional correctness.

Damaged components must be exchanged immediately on site and may no longer be used.

Safety components are to be removed only when they are no longer required.

When on slab formwork, scaffolds and working platforms:

- do not jump,
- do not run,
- do not drop anything from or onto it.

Components provided by the contractor must comply with the characteristics stipulated in these Instructions for Assembly and Use and all applicable laws and standards. Unless otherwise indicated, the following applies in particular:

- Timber components:  
Strength Class C24 for Solid Wood according to EN 338:2016-07.
- Scaffold tubes:  
galvanised steel tubing with minimum dimensions  $\varnothing 48.3 \times 3.2$  mm according to EN 12811-1:2004-03 4.2.1.2.
- Scaffold tube couplings: according to EN 74-1:2022-09 and EN 74-2:2022-09.

Deviations from the standard configuration are only permitted after a further risk assessment has been carried out by the contractor.

Appropriate measures for working and operational safety, as well as stability, are defined on the basis of this risk assessment.

Corresponding proof of stability can be provided by PERI on request if the risk assessment and resulting measures to be implemented are made available.

Nails and wood screws must not protrude. Only allow other connecting components to protrude to the extent that is necessary.

If necessary, mark protruding components or fit them with protective material.

Secure all bolts with cotter pins and all screws with nuts

Before and after exceptional occurrences that may have an adverse effect on the safety of the formwork system, the contractor must immediately

- produce another risk assessment and make use of its results to take suitable steps to guarantee the stability of the formwork system,
- arrange for an extraordinary inspection to be carried out by a competent person qualified to do so. The aim of this inspection is to identify and rectify any damage in good time in order to guarantee safe use of the formwork system.

Exceptional events could be:

- accidents, fire, explosions, collisions,
- long periods of non-use,
- natural events, e.g. heavy rainfall, heavy snowfall, significant icing, storms or earthquakes.

Suitable measures could be:

- removing nets/tarpaulin,
- clearing snow and ice,
- reducing live loads,
- securing loose materials.

### Assembly, modification and dismantling work

PERI systems may only be assembled, modified or dismantled under the supervision of a person qualified to do so and by suitably qualified employees. The qualified personnel must have received appropriate training for the work to be carried out with regard to specific risks and dangers.

On the basis of the risk assessment and the Instructions for Assembly and Use, the contractor must create assembly instructions to guarantee safe assembly, modification and dismantling of the DUO Lightweight System.



The contractor must ensure that the personal protective equipment required for the assembly, modification or dismantling of the system, e.g.

- Safety helmet,
- Safety shoes,
- Safety gloves,
- Safety goggles,

is available and used as intended.

For work at a higher level, use an approved ladder or platform system, or an assembly scaffold.



If personal protective equipment against falling from a height (PPE) is required or specified in local regulations, the contractor must determine appropriate attachment points on the basis of the risk assessment.

The PPE to be used to prevent falling is determined by the contractor.

Before use, define rescue measures in the event of a fall, taking into account all possible emergencies at work.

A rescue must be carried out within 20 minutes to avoid suspension trauma.

Ensure that first aid is available!

The PPE to be used is determined by the employer.

The contractor must provide safe working areas for site personnel which are to be reached via safe access routes.

The contractor must ensure that the following points are observed:

- If necessary, secure single components and assemblies to prevent them from falling, e.g. using ropes.
- Cordon off and signpost danger zones.
- Ensure stability during all construction stages.
- Ensure and demonstrate that all loads that occur are safely transferred.

### Use

Every contractor who uses or allows formwork systems or sections of the formwork to be used, is responsible for ensuring that the equipment is in good condition.

If the formwork system is used successively or at the same time by several contractors, the health and safety coordinator must point out any possible mutual hazards and all work must be then coordinated.

When systems are used in publicly accessible areas,

- measures to prevent unauthorised use, e.g. enclosure of access areas, must be taken.
- measures are taken against injuries caused by bumping against protruding components, e.g. assembly of protective components.

Always keep the contact surfaces of the system free of dirt, objects, snow and ice.

Close off the system in extreme weather conditions.

## System-specific

Retract components only when the concrete has sufficiently hardened and the person in charge has given the go-ahead for striking to take place.

Only use PERI lifting accessories.

During striking, do not tear off the formwork elements with the crane.

Check the usability by referring to the production date. Remove and dispose of components that have exceeded the period of usability.

Anchoring is to take place only if the anchorage has sufficient concrete strength.

The inspection of the anchorage and its parts must be carried out by the contractor (user).

It is not permitted to enclose the platform or to attach additional surfaces for the wind to attack.

Have the platforms checked for damage at regular intervals by authorized and competent persons.

Remove any soiling that impairs the function immediately.

When stepping onto platforms, watch out for hazards and use PPE if necessary.

When working on free fall edges, such as when moving platforms, personnel must be secured against falling (e.g. using PPE). Cordon off danger zones.

Persons, building materials or tools must not be transported with the crane when moving. Exceptions can be defined in work and assembly instructions based on a risk analysis by the contractor.

When operating hoists near the platforms, there is a risk of unintentional unhooking.

Take these dangers into account when drawing up the site-specific work and assembly instructions.

### Wall system, column system

If a storm warning is issued, additional push-pull props are to be attached or other bracing measures are to be carried out along with implementing the details contained in the PERI Design Tables.

### Slab system

Take into account the permissible slab thickness and prop loads.

The load-bearing capacity of the slabs that have been completed must be activated so as to avoid overloading of the slab props during vertical concreting cycles. For this, free deflection capability is required for these components. This can be done by releasing and re-installing all slab props available.

The load-distributing support used, such as planking, must match the respective base used. If several layers are required, planks are to be arranged crosswise.

Only ever use means of ascent and descent that have been provided for this purpose. No climbing! Do not jump on or off slab formwork and do not throw anything off slab formwork.

The actual prop loads must be safely transferred using slab props with a sufficient load-bearing capacity or shoring systems.

When storing heavy items on the formwork, the load-bearing capacity of the formwork construction must be taken into consideration.

Cantilevers may only be accessed when the bracing has been mounted.

The horizontal fixed position of the slab formwork must be guaranteed. This is provided by circumferential walls and pre-concreted beams. Otherwise, the transfer of the horizontal loads has to be guaranteed by means of other measures supplied by the contractor (e.g. bracing). Load assumptions for horizontal loads in accordance with DIN EN 12812.

With wind speeds of 26 km/h and more, the panels must be connected with DUO couplers to form larger units. Pre-assembled units must not exceed a maximum weight of 65 kg! For unfavourable structure geometries or larger wind speeds, additional securing measures are to be implemented, e.g.:

- ballast,
- bracing,
- dismantling the formwork etc.

Wind speeds for which additional measures should be taken, must be determined in a project-related manner as part of a risk assessment.

Permissible temperature range for use, cleaning, storage and transportation: -20 °C – +60 °C.



## General information

- Store and transport components ensuring that no unintentional change in their position is possible. Detach lifting accessories and slings from the lowered components only if they are in a stable position and no unintentional change is possible.
- Do not drop the components.
- Only use approved and tested PERI transport equipment including lashing, lifting gear and slings.
- Only attach transport equipment to designated attachment points with suitable lifting gear and slinging equipment with a positive fit.

## During the moving procedure

- ensure that components are picked up and set down in such a way that unintentional falling over, falling apart, sliding, falling down or rolling is avoided.
- Always use ropes to guide wind-prone components or assemblies when moving them with a crane.
- no persons are allowed to remain under the suspended load.
- The access areas on the construction site must be free of obstacles and tripping hazards and must also be slip-resistant.
- For transportation, the base must have sufficient load-bearing capacity.
- Use original PERI storage and transport systems, e.g. pallet cages, pallets or stacking devices.

For outdoor storage, the formwork panels and attachment parts must be protected against direct sunlight and the effects of the weather.



- Instructions for Use for PERI pallets, stacking devices and pallet lifting trucks must be taken into consideration!
- Manually-created transportation units must be correctly stacked and secured!

## Transportation

PERI stacking racks and stacking devices are suitable for lifting by crane or forklift. They can also be moved with the PERI pallet lifting trolley. All pallets and stacking devices can be lifted using both the longitudinal and front sides.

Suitable PERI pallets and stacking devices are available for material-friendly transport.

### DUO stacking devices (1)

Each DUO stacking device can lift up to 75 kg. As a unit (four DUO stacking devices), up to 300 kg. (Fig. A1.01)

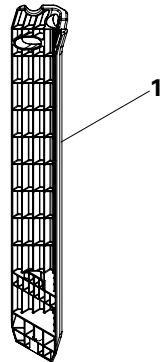

Fig. A1.01

### PERI wooden pallets (2)

For DUO panels DP and DMP  
 135 x 90 (2.1)  
 135 x 75 (2.2)  
 135 x 60 (2.3)  
 (Fig. A1.02)

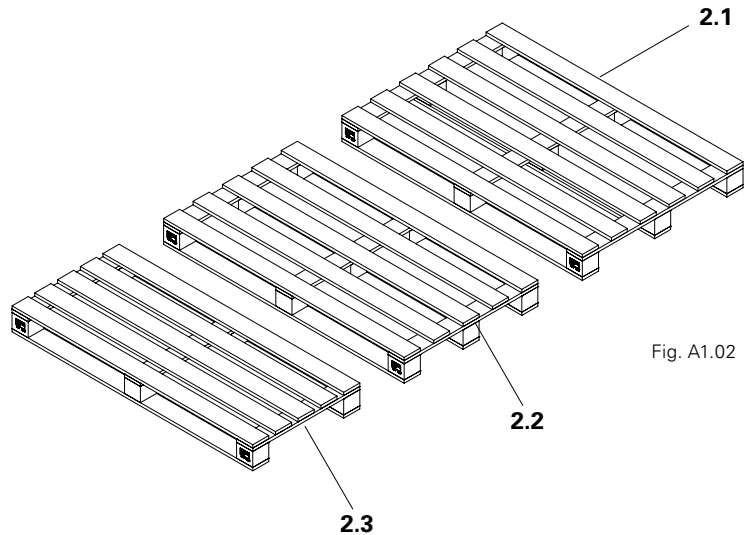

Fig. A1.02

### 80 x 120 wire box pallets (3)

- Permissible load-bearing capacity 1500 kg.
- Four-sling lifting gear  $L \geq 3$  m.

For wall thickness compensator DWC 60, filler panel DFS 60, corner post DC 60, chamfer strip DUO 60 and additional accessories. (Fig. A1.03)

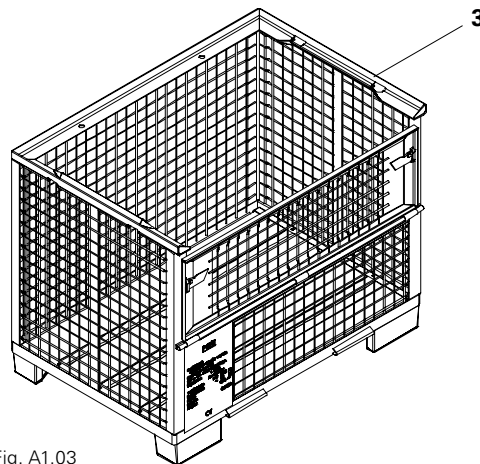

Fig. A1.03

### 80 x 120 RP-2 pallets (3.1)

- Permissible load-bearing capacity 1500 kg.
- Four-sling lifting gear  $L \geq 3$  m.

For wall thickness compensator DWC 135, filler panel DFS 135 and corner post DC 135. (Fig. A1.03a)

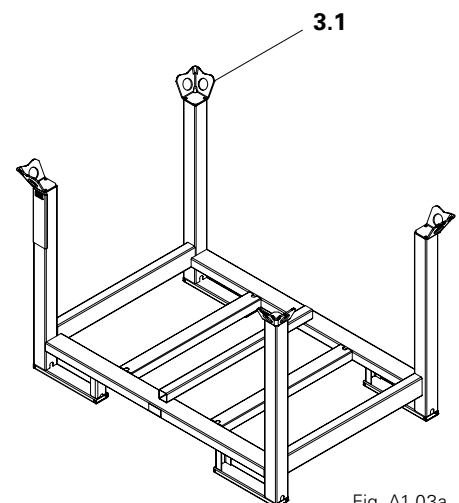

Fig. A1.03a



The DUO Stacking Device is classed as a lifting accessory according to LOLER and requires a relevant inspection regime. The item is only available in the UK as a Safe Only item.

## Panels on wooden pallets

- 10 layers of DUO panels (**10**).
- The stacked panels must have the same dimensions.
- To prevent the panels from sliding, use DUO stacking aid (**4**) in every layer and at every tie point. With multi panels, use the 4 outermost tie points.
- Stack all panels with the formlining facing upwards. Place a protective sheet on the top panel in order to prevent damage to the formlining. (Especially important when placing several stacks on top of one another.) (Fig. A1.04)
- Secure panels with steel strapping and edge protection.
- Wooden pallets are not suitable for transport by crane.

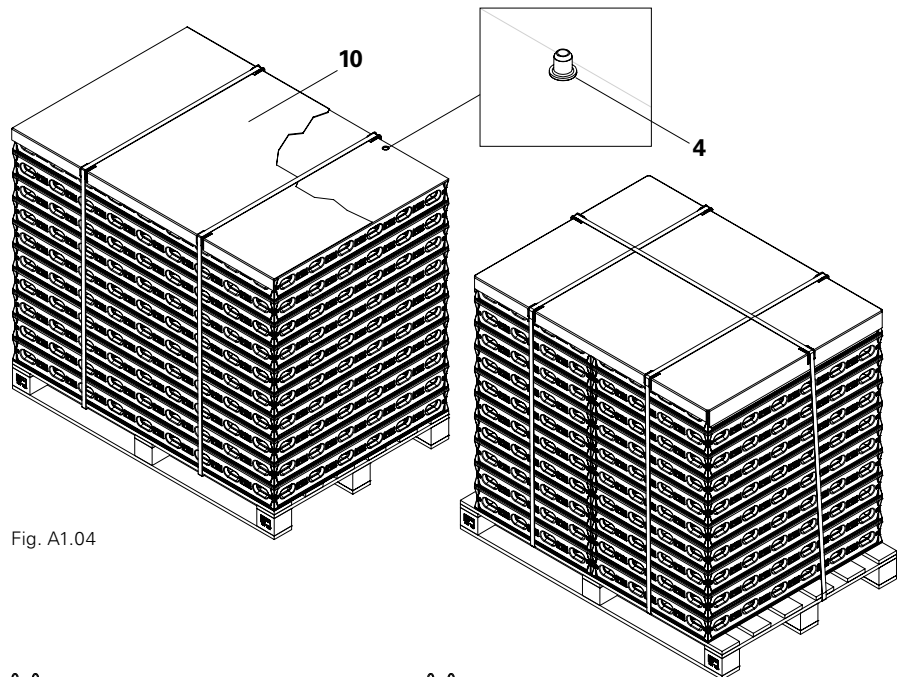

Fig. A1.04

## Stacking devices

- Levels 1, 2 and 10 must:
  - have the same dimensions,
  - be placed in the stacking device with the formlining facing upwards.
- The following applies to levels 3 to 9:
  - Panel sizes may deviate from the sizes of the panels in levels 1, 2, and 10.
  - It is possible, for example, to place panels with the same length but a different width in one level.
  - The overall width of all panels in one level must correspond to the width of the panels in levels 1, 2 and 10.
  - There must be no hollow spaces between the panels.
- Secure the top panel on each stacking device with at least one DUO coupler (**21**). (Fig. A1.06 + Fig. A1.06a)  
See A3, DUO couplers.

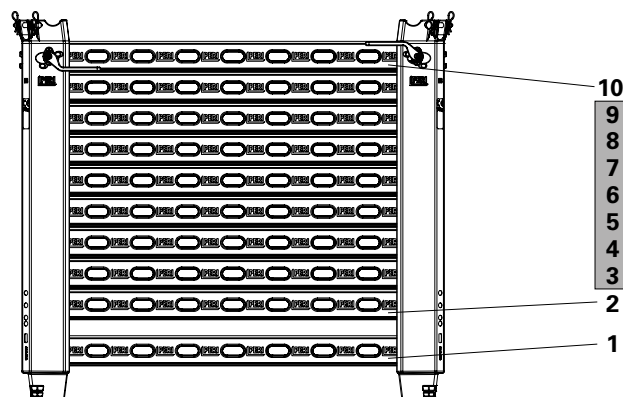

Fig. A1.05

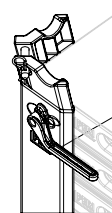

Fig. A1.06a

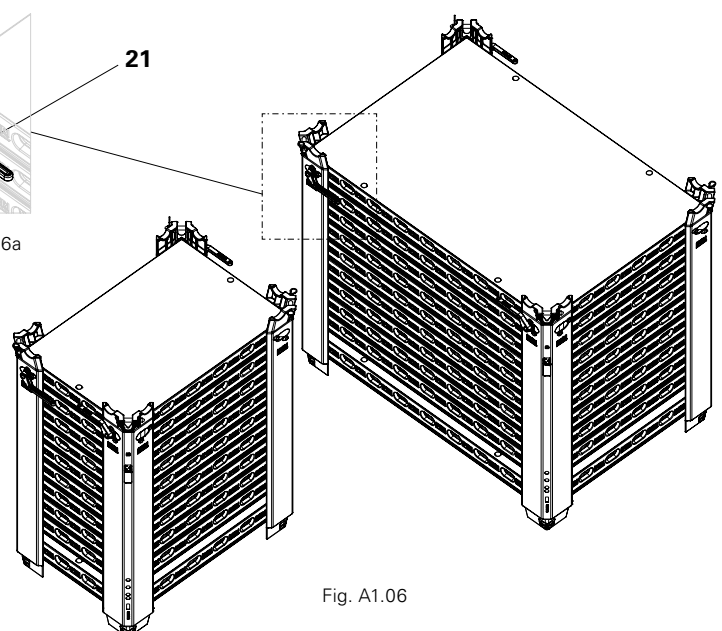

Fig. A1.06

## Stacking height on the truck

A maximum of two stacks on top of each other.

Only start a new stack when the first stack of 10 panels is complete.

The number of stacks that can be transported depends on the respective national transport regulations.



## Warning

Excessive loads or incorrectly secured heavy loads may topple over!

Falling loads can result in serious injuries.

⇒ Only ever move one stack at any one time!

⇒ Length of 4-sling lifting gear  $\geq 3$  m!

## Storage and transportation on the construction site

Stacks which are formed using stacking devices can be moved with the crane. To do so, attach the lifting gear (6) at the corners of each stacking device (load-bearing point). (Fig. A1.07)

If 2 or more stacks are placed on top of each other, secure the top panel on each stacking device by means of 2 DUO couplers (21).

(Fig. A1.08)

For horizontal transport on the construction site, DUO wheels (7) can be inserted into the underside of the stacking devices.

(Fig. A1.09)

1. Insert wheels when stack is in a raised position.
  - Wheels are secured by means of locking clips.
2. Make sure that wheels are correctly mounted.



Remove all DUO wheels before individual stacks are loaded onto a truck or container.

(Fig. A1.09+ Fig. A1.10)

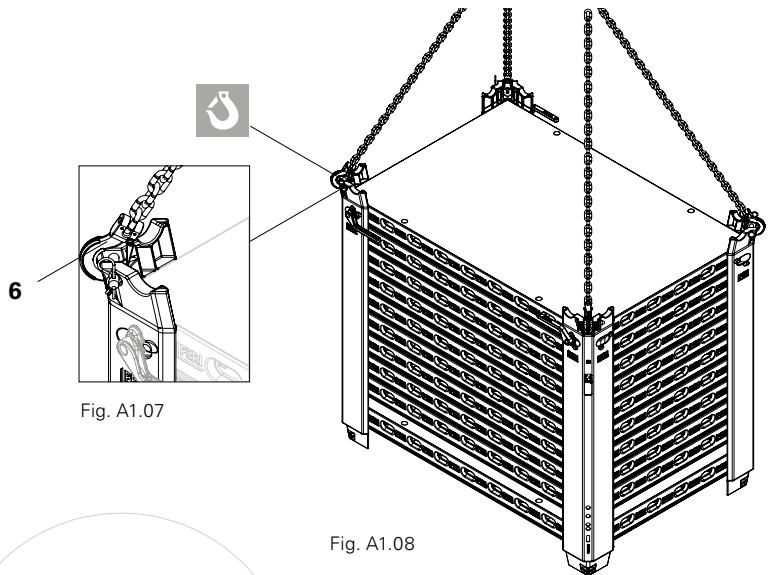

Fig. A1.07

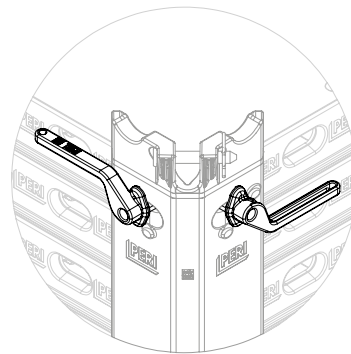

Fig. A1.08

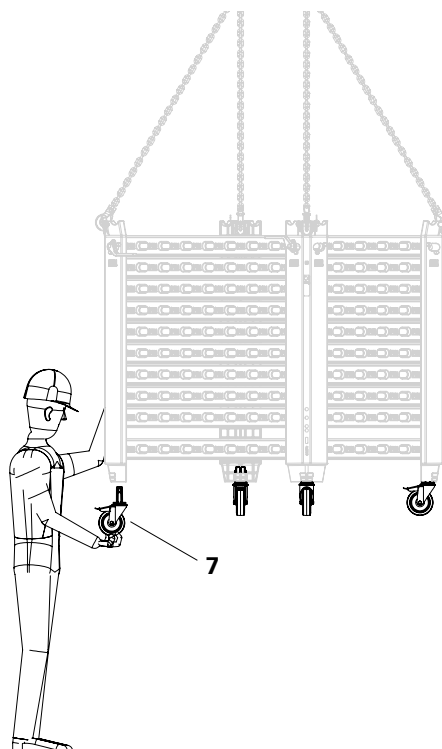

Fig. A1.09

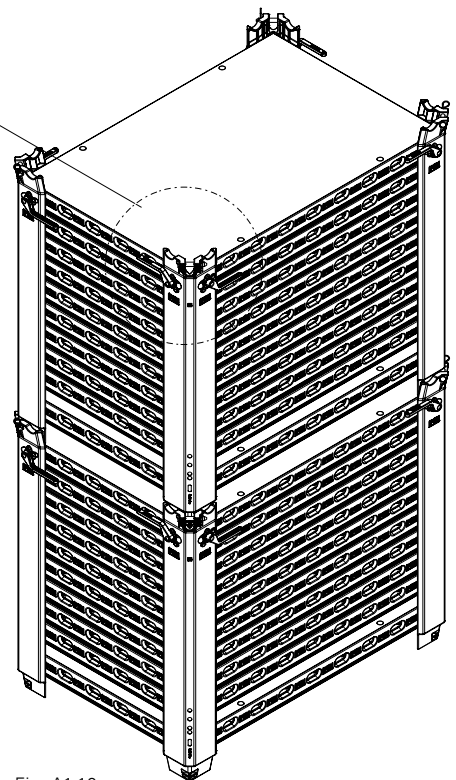

Fig. A1.10

## Panel overview

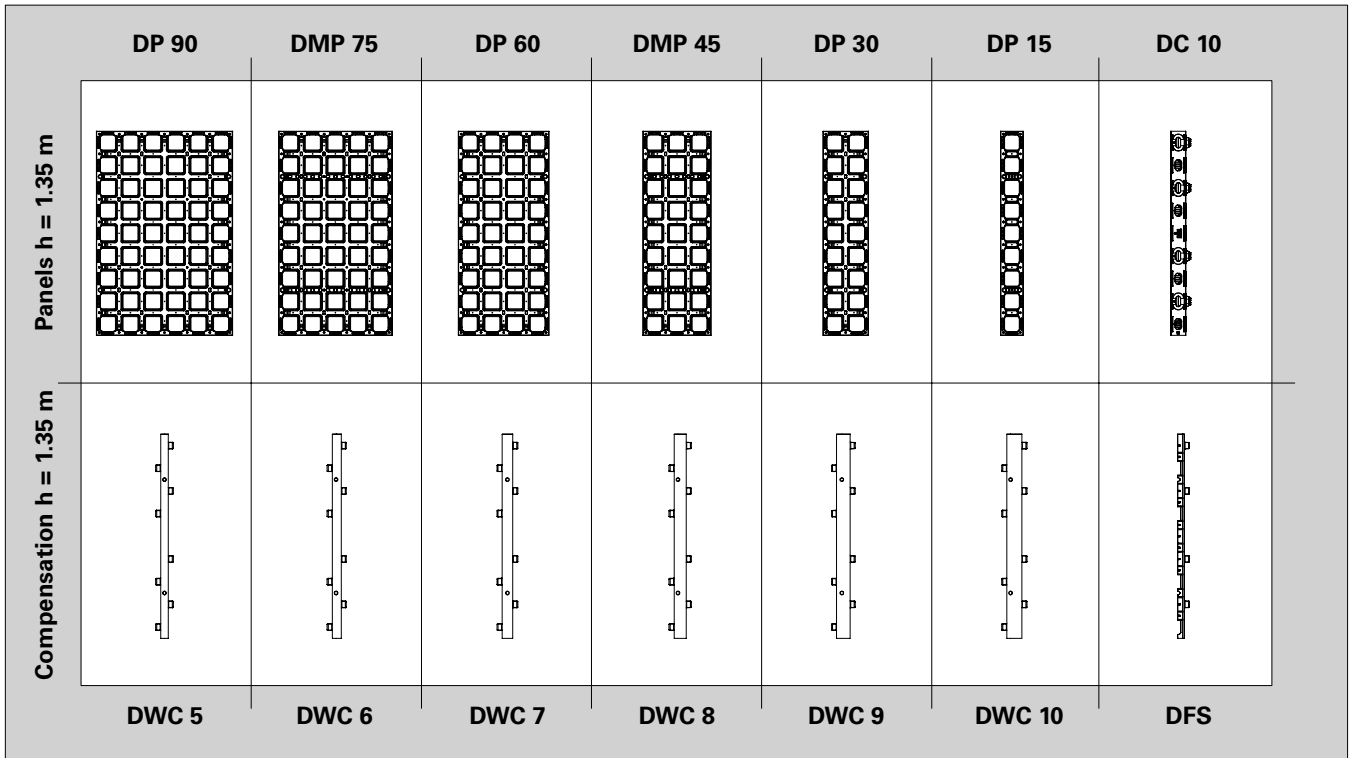

Fig. A2.01

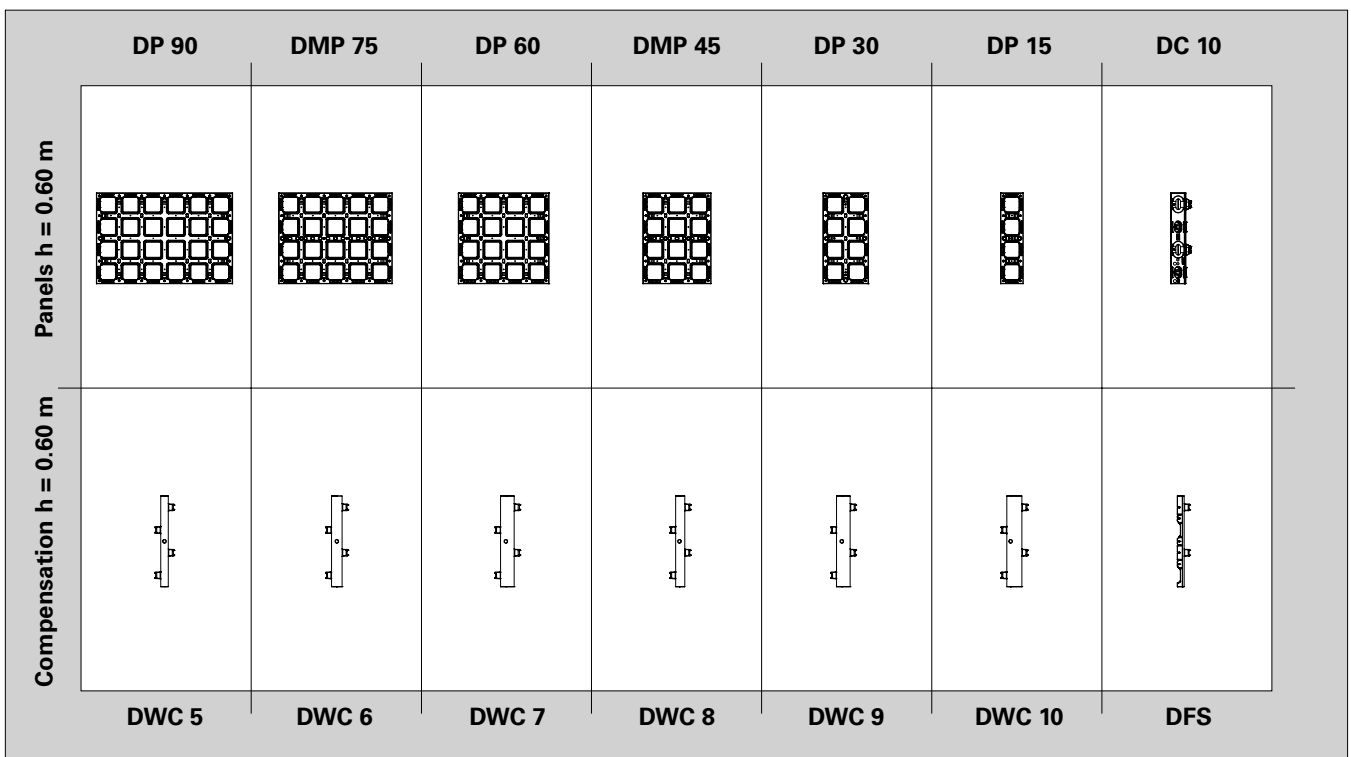

Fig. A2.02

## DP panel

Example DP 135 x 90.  
(Fig. A2.03)

- 10** DP panel
- 10.1** Tie point
- 10.2** Connector pocket
- 10.3** Connection point for scaffold bracket, push-pull props and other accessories
- 10.4** Coupler recess
- 10.5** Frames
- 10.6** Frame strut
- 10.7** DUO formlining

Panel width  
90, 60, 30, 15 cm.

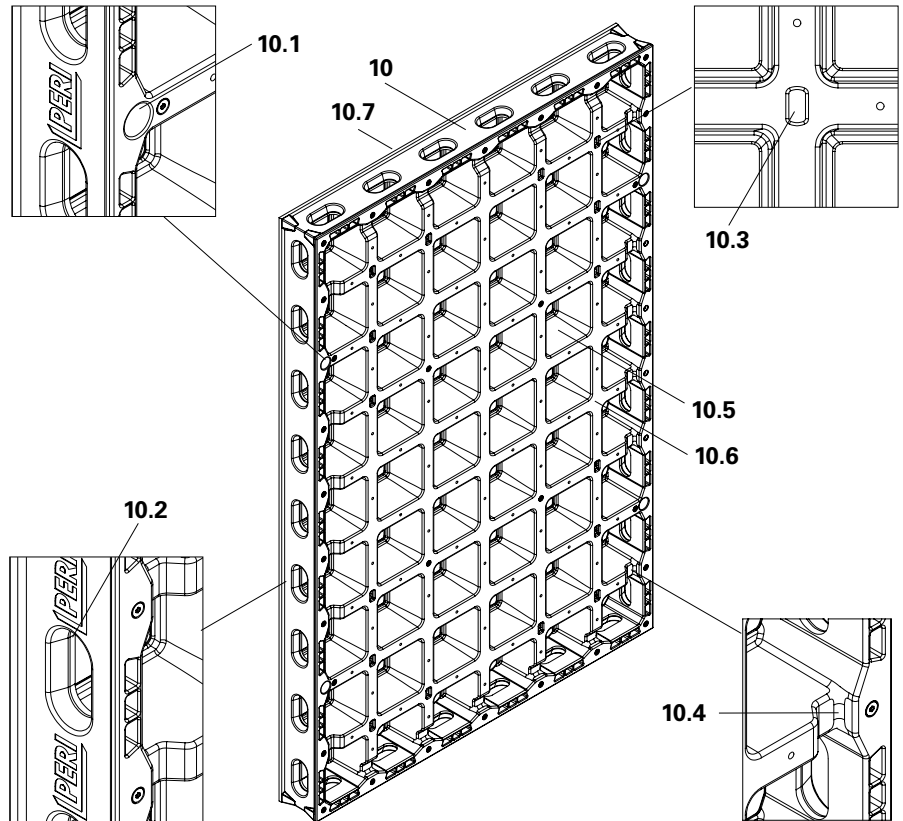

Fig. A2.03

Example DP 60 x 90.  
(Fig. A2.03a)

The second construction height of the DP DUO panels makes it easier to adjust the height of the system. The DP panels do not need to be turned into the horizontal position.

The DP panel only has one row of tie points at a height of 30 cm.

Panel width  
90, 60, 30, 15 cm.

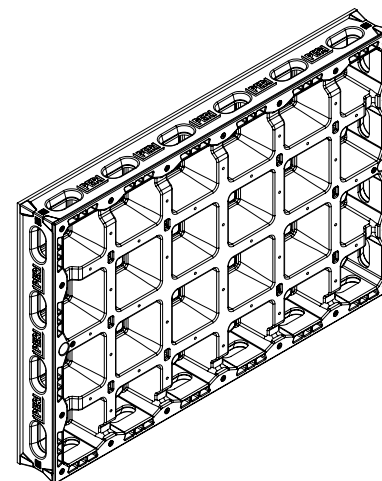

Fig. A2.03a

## DMP multi panel

Example DMP 135 x 75.  
(Fig. A2.04)

In addition to the DP panel, the multi panel is equipped with anchor struts.

- 12** DMP multi panel
- 12.8** Anchor strut, reinforced with steel insert

Panel width  
75, 45 cm.

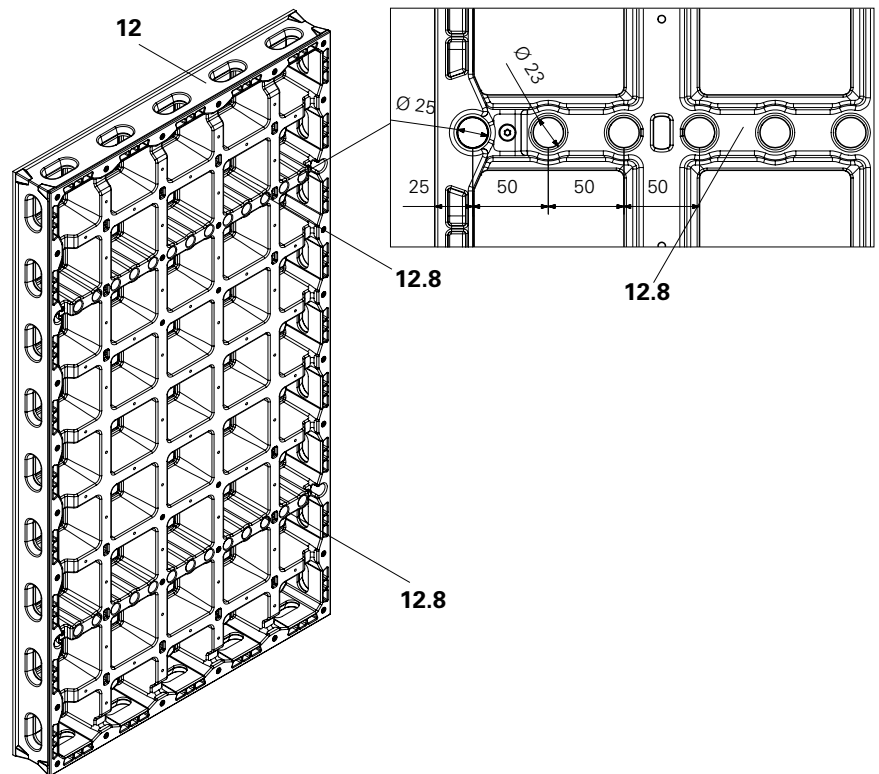

Fig. A2.04

Example DMP 60 x 75.  
(Fig. A2.04a)

The second construction height of the multi panels is equipped with an anchor strut at a height of 30 cm.

Panel width  
75, 45 cm.

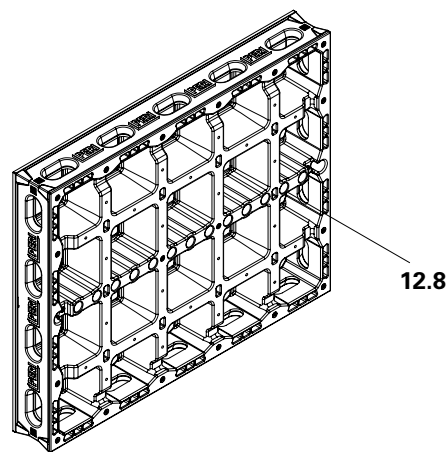

Fig. A2.04a

## DFP filler panel

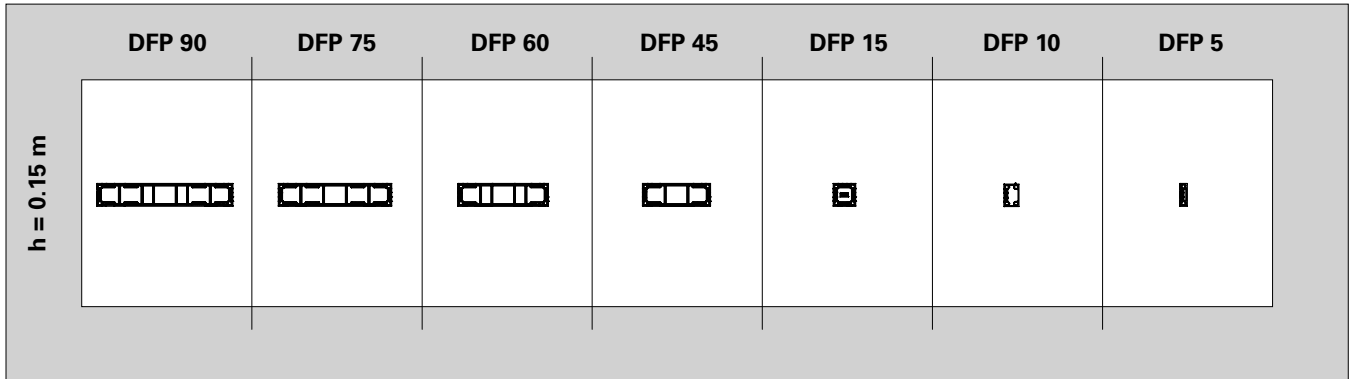

Fig. A2.05



### Warning

The component may end up being subjected to excessive loads!

The component could collapse!

- ⇒ Always install DFP filler panels (17) as the top element on DP panels 135 or 60.
- ⇒ Attaching lifting gear to the DFP filler panel (17) is not permitted.
- ⇒ Install filler panels only when formwork panels are in position and secured.
- ⇒ Mount no more than 3 rows of DFP filler panels (0.45 m)!

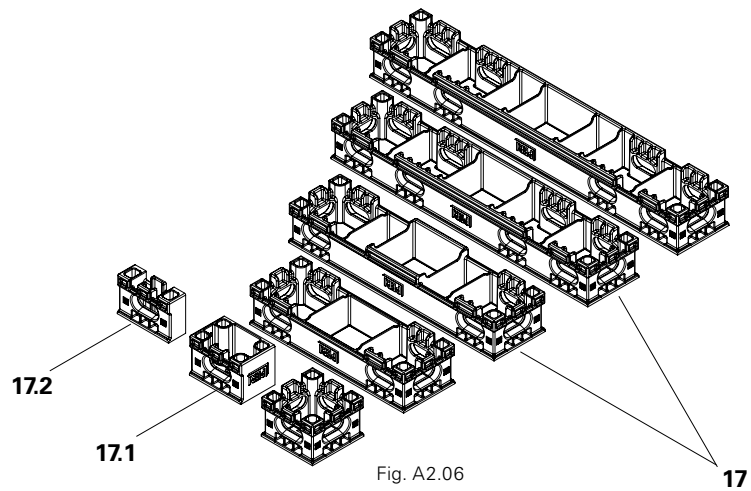

### Use

Use DFP filler panels (17) as:

- extension panels for vertical formwork situations or
- as filler panels for backpropping of slab formwork.

When carrying out extensions with filler panels: Use 15 x 10 DFP filler panels (17.1) as:

- corner panels and
- wall thickness compensation.

As additional wall thickness compensation, use 15 x 5 DFP filler panels (17.2).

## Tools



Carry out all forming procedures without a hammer in order to avoid damage to DP panels, couplers and all other components.

Where necessary, only use a rubber hammer (9). (Fig. A3.01a)

Use the DUO cleaning device (8) to clean DP panels and for tightening and loosening DW 15 wingnut counterplates (54). (Fig. A3.01b)

### Used in:

- DW 15 wingnut counterplate (54)
- DW 15 wingnut pivot plate (56) (Fig. A3.01c)

## DUO couplers

### Used in:

- Standard panel joint
- Corners, see section B5 Corners
- T-junctions, see section B6 T-junctions, wall connections
- Wall offsets, see section B7 Wall offsets
- Length compensations, see section B8 Length compensation
- Column formwork, see section C1 Column formwork
- Shear walls, see section C2 Shear walls
- Storage and transportation, see section A1 Storage and transportation

### Standard panel joint

Number of DUO couplers (21) per standard panel joint:

### Required components:

<b>21a</b> DUO coupler short joint	2x
<b>21b</b> DUO coupler long joint	3x

(Fig. A3.02 – Fig. A3.02c)



The DUO accessories bag (art. no. 131205), which is used to store various DUO accessories, can be used to take additional DUO couplers along with you.

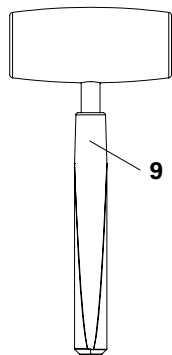

Fig. A3.01a

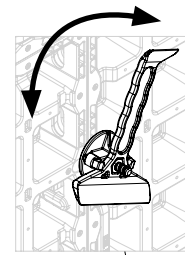
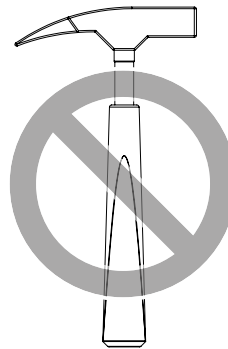

Fig. A3.01b

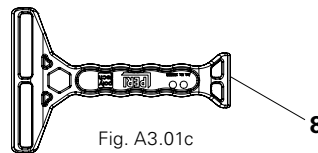

Fig. A3.01c

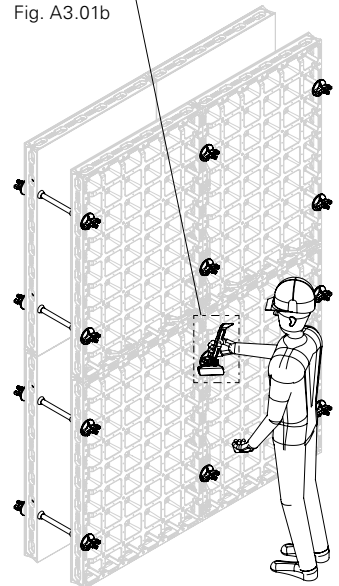
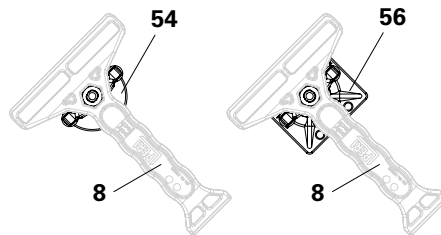

Fig. A3.01

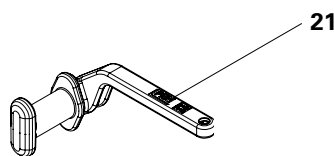

Fig. A3.02

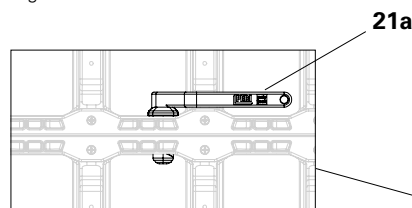

Fig. A3.02a

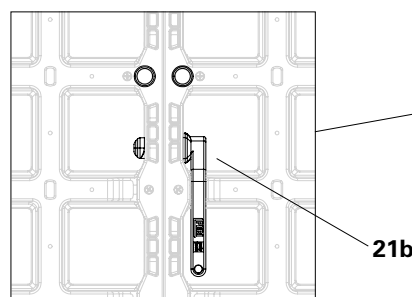

Fig. A3.02b

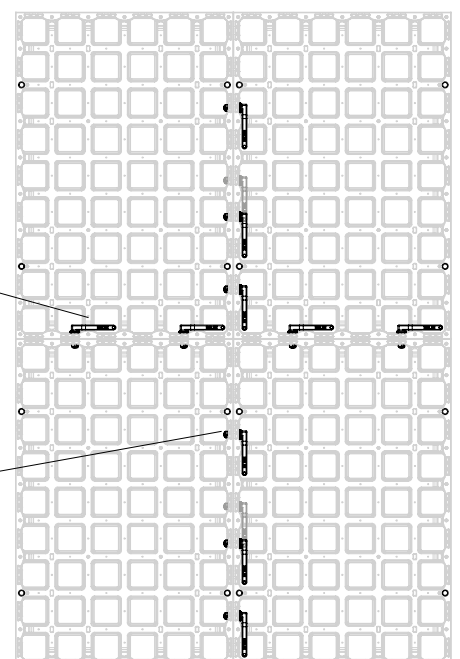

Fig. A3.02c

## Positions with DP 135 panels

Long panel joints:

(Fig. A3.03 + Fig. A3.03a)

- DUO coupler (**21c**) in connector pocket directly below the top tie point (**10.1**).
- DUO coupler (**21e**) in connector pocket directly below the bottom tie point (**10.1**).
- DUO coupler (**21d**) between the other two couplers, in one of the middle connector pockets.

Short panel joints:

- In the second connector pocket from the outside in each case (**21f**), (**21g**).



With external corners, other quantities and positions are to be taken into account, see section B5 Corners.

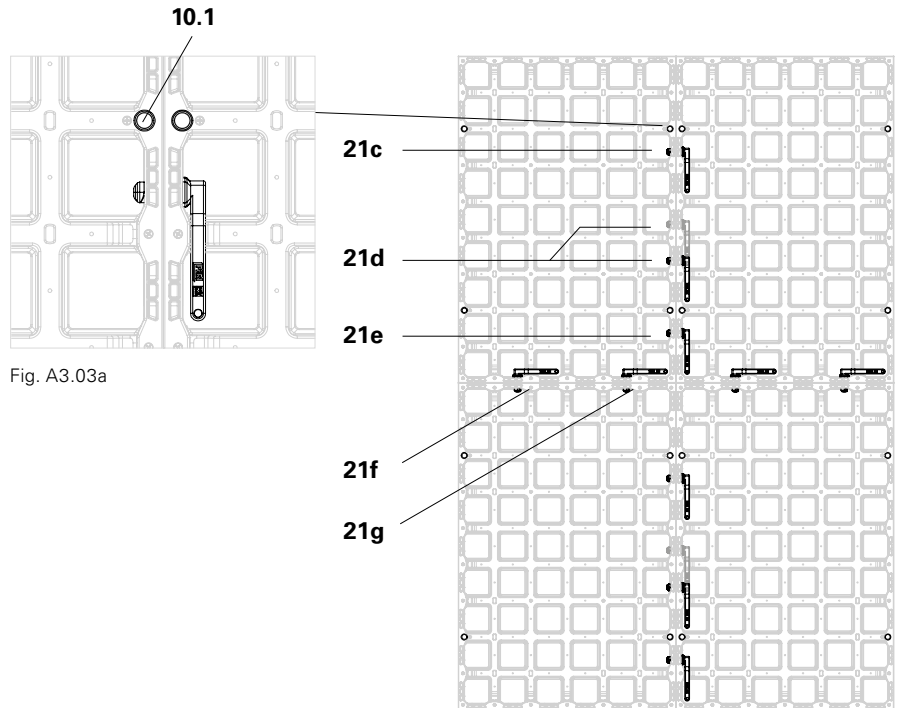

Fig. A3.03a

Fig. A3.03

## Installation



Only ever insert and tighten DUO couplers (**21**) by hand!

1. Insert the DUO coupler (**21**) into the connector pocket up to the limit stop. (Fig. A3.03b + Fig. A3.03c)
2. Swivel the hand grip until it completely disappears in the coupler recess of the DP panel. (Fig. A3.03d + Fig. A3.03e)

If the DUO coupler (**21**) is inserted from the right-hand side, the hand grip has to be swivelled downwards.  
If inserted from the left, the hand grip has to be swivelled upwards. (Fig. A3.03e)

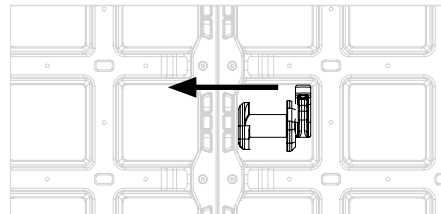

Fig. A3.03b

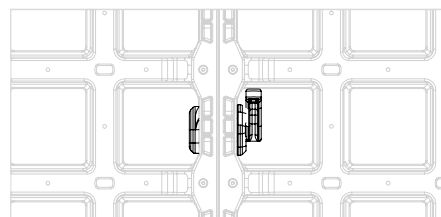

Fig. A3.03c

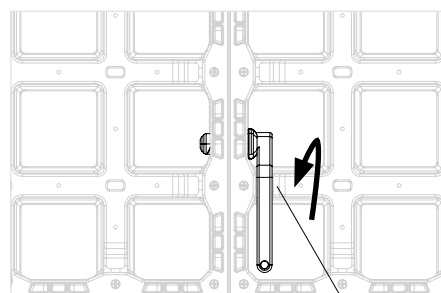

Fig. A3.03d

**21**

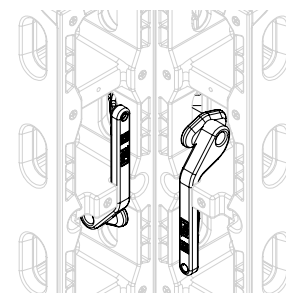

Fig. A3.03e

## Positions with DP 60 panels

Short panel joints:

- DUO coupler (**21a**) in the top connector pocket.
- DUO coupler (**21b**) in connector pocket directly below the tie point.

Long panel joints:

- DUO coupler (**21c**) in the second connector pocket from the outside in each case. (Fig. A3.04)

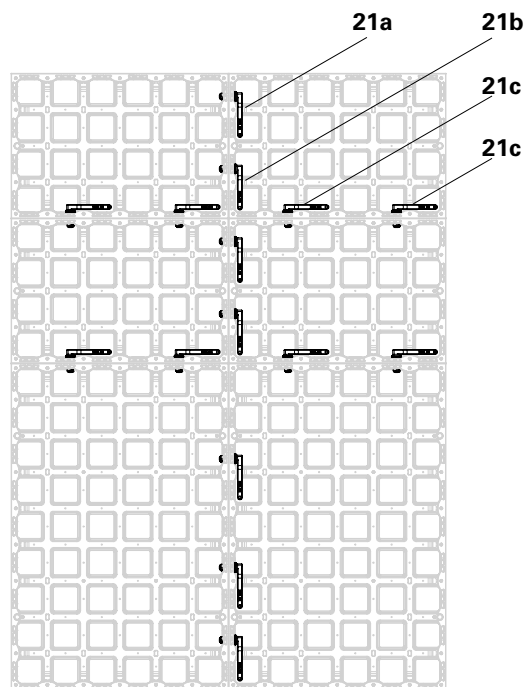

Fig. A3.04

## Positions with DFP filler panels

- Mount DUO coupler (**21d**) in the connector pocket that is positioned closer to the centre in each case. (Fig. A3.05)

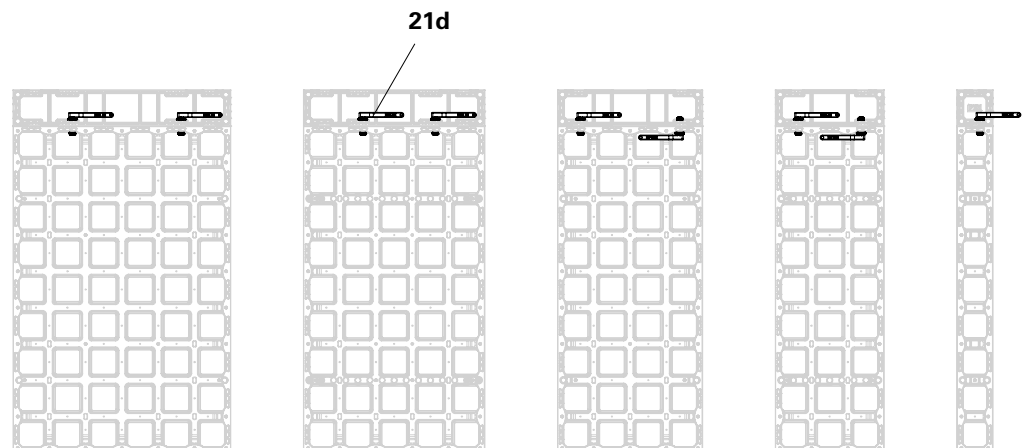

Fig. A3.05



With external corners, other quantities and positions are to be taken into account, see section B5 Corners.

## DUO coupling ties

In combination with the DUO DW 15 grip (**22.2**), the DUO coupling tie (**22.1**) can be used for square timber compensations  $\leq 5$  cm. (Fig. A3.06b / Fig. A3.06d)

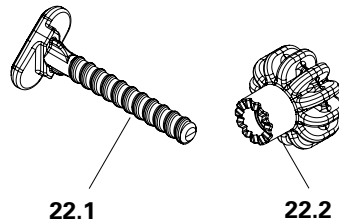

Fig. A3.06a

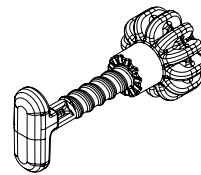

Fig. A3.06

## Installation

1. Drill 6 holes with a diameter of 20 mm into square timber that is no more than 5 cm wide. Strictly adhere to the drilling plan (Fig. A3.06c) in order to be able to insert the DUO coupling tie (**22**).
2. Position the square timber between the DP panels.
3. From one side, push the DUO coupling tie (**22.1**) through the connector pockets and square timber.
4. From the other side, screw on the DUO DW 15 grip (**22.2**) by hand. (Fig. A3.06d).
5. Mount compensation waler DUO 62, see section A3 Panel connections compensation waler DUO 62 and B8 Length compensation.

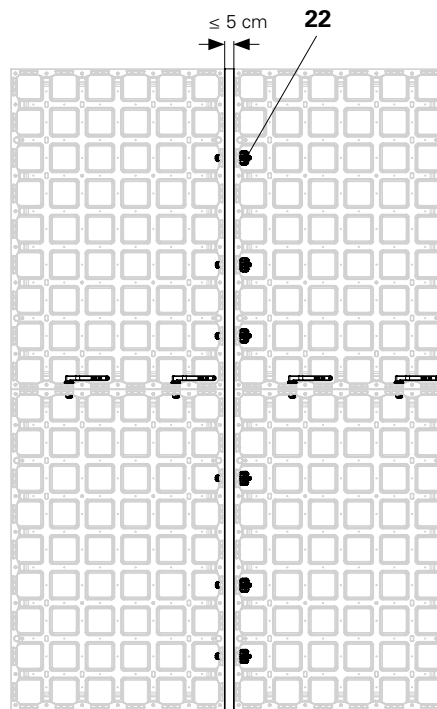

Fig. A3.06b

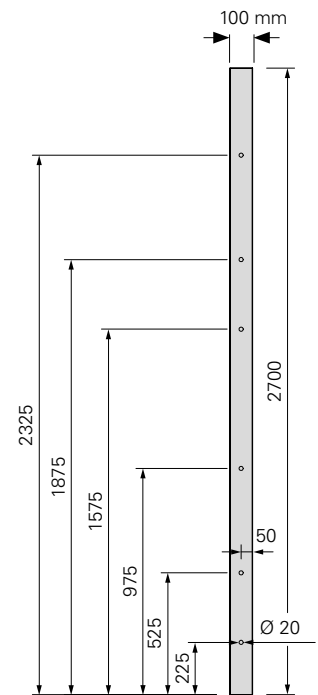

Fig. A3.06c

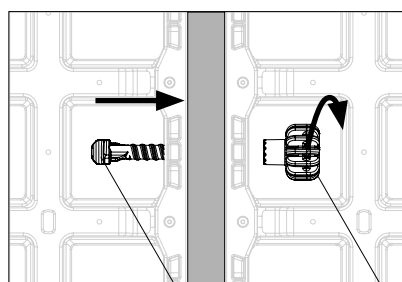

Fig. A3.06d

22.1

22.2

## DUO corner ties

The DUO corner tie (**23.2**) can be used with:

- The DW 15 wingnut counterplate (**54**) and DUO compensation waler (**25**) for stopend formwork (Fig. A3.07a+ Fig. A3.07b).
- DUO corner connector (Fig. A3.08a).

### Used in:

- Stopend formwork, see section B9 Stopend formwork
- 90° corners, see section B5 Corners
- Column formwork, see section C1 Column formwork
- Shear walls, see section C2 Shear walls
- Wall offsets, see section B7 Wall offsets

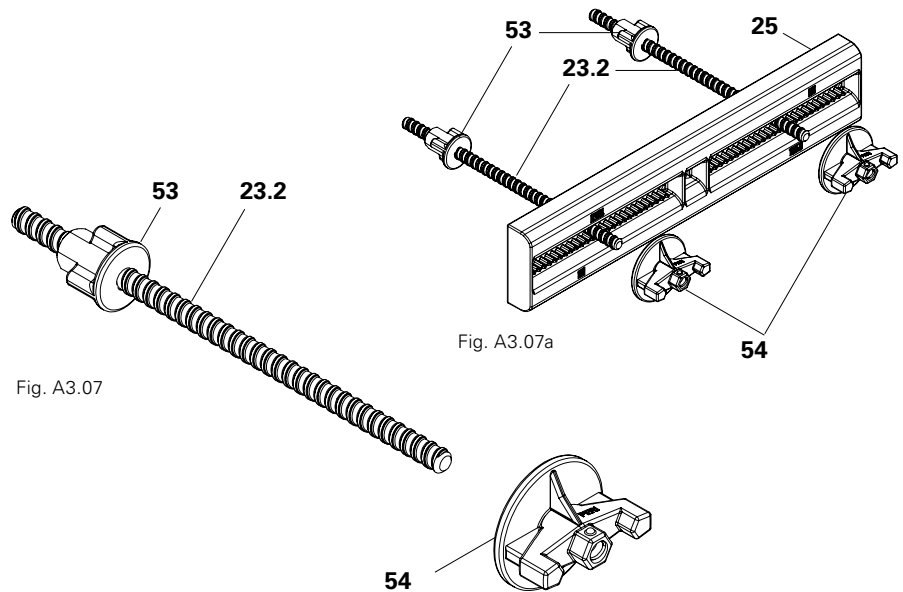

Fig. A3.07

Fig. A3.07a



Only ever tighten the DW 15 wingnut counterplate (**54**) with the DUO cleaning device (**8**)!

### Installation

1. Insert the DUO corner tie (**23.2**) through the connector pocket at the required position.
2. On the panel side, screw cam nut (**53**) onto the DUO corner tie (**23.2**).
3. Place the DUO 62 compensation waler (**25**) on the DUO corner tie (**23.2**) and hold it securely.
4. Screw the DW 15 wingnut counterplate (**54**) onto the DUO corner tie (**23.2**) by hand. (Fig. A3.07b + Fig. A3.07c)

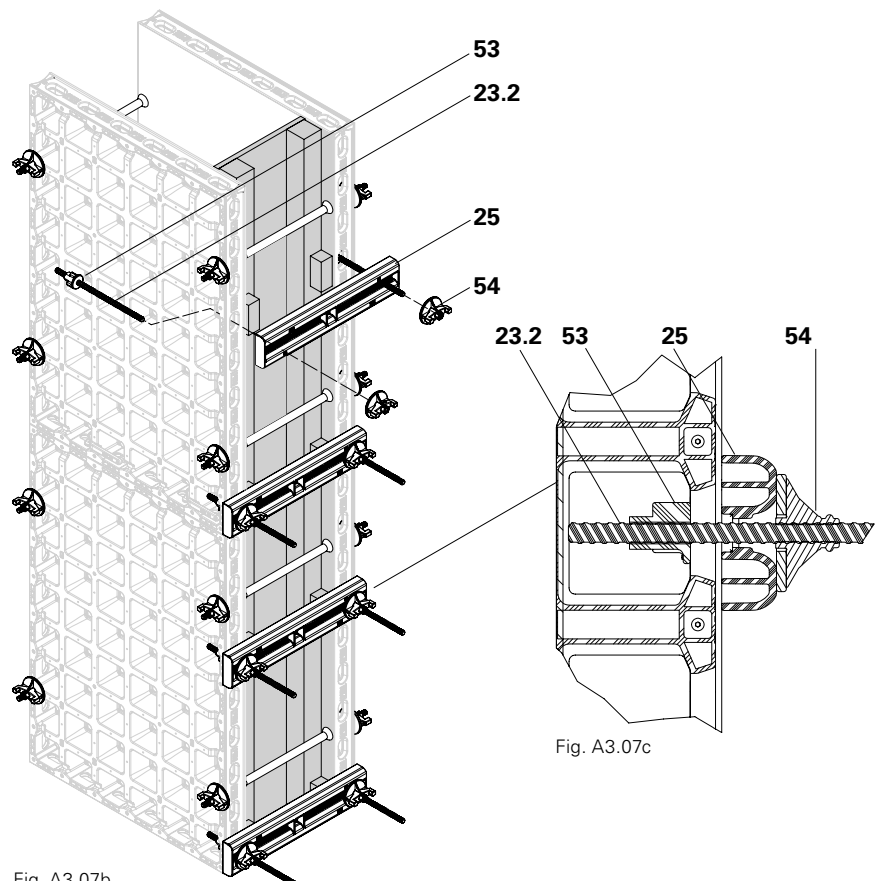

Fig. A3.07b

Fig. A3.07c

## DUO corner connectors

The DUO corner connector (**23**) is used to connect panels at right-angles. The panel positioned at a right angle must be a DMP multi panel (**12.2**). (Fig. A3.08)

### Used in:

- 90° corners, see section B5 Corners
- Stopped formwork, see section B9 Stopped formwork
- Column formwork, see section C1 Column formwork
- Shear walls, see section C2 Shear walls
- Wall offsets, see section B7 Wall offsets

### Installation

1. Disassemble the DUO corner connector (**23**), screw the cam nut (**53**) onto the DUO corner tie (**23.2**).
2. Position the DMP 75 multi panel (**12.2**) in front of the last panel at a right angle.
3. Insert the DUO corner connector (**23**) into the frame strut of the panel.
4. Insert the steel pin (**23.4**) of the DUO corner connector into the appropriate tie point (**10.1**) of the DMP 75 multi panel (**12.2**). (Fig. A3.08b)
5. Push the DUO corner tie (**23.2**) through the DUO corner connector (**23**) and the DMP multi panel (**12.2**). (Fig. A3.08c)
6. Tighten with the DW 15 wingnut counterplate (**54**) from the rear by hand or with the DUO cleaning device (**8**). See section A3, panel connections, tool. (Fig. A3.08d + Fig. A3.08e)

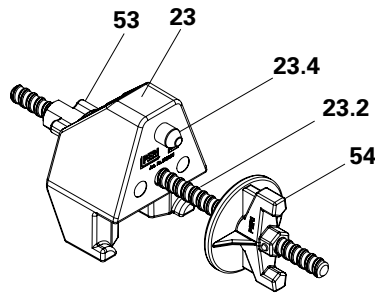

Fig. A3.08a

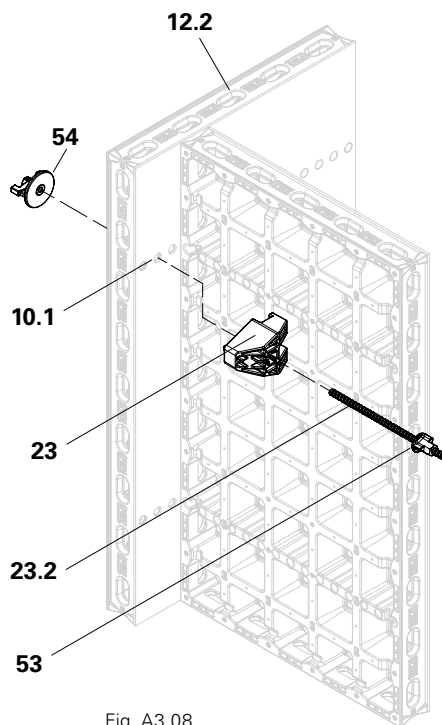

Fig. A3.08

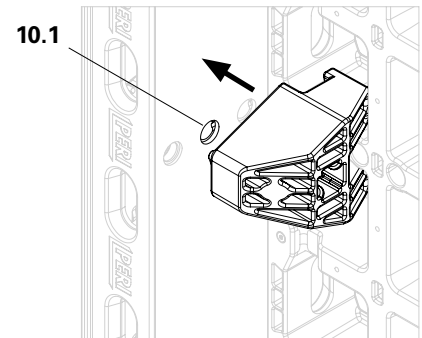

Fig. A3.08b

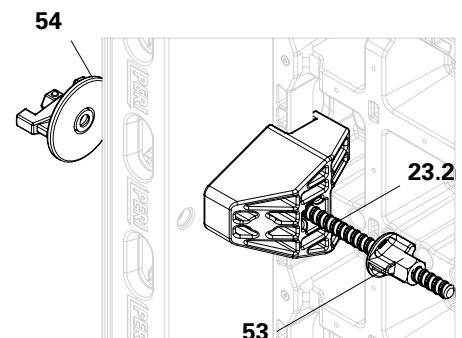

Fig. A3.08c

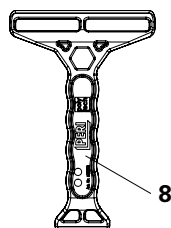

Fig. A3.08e

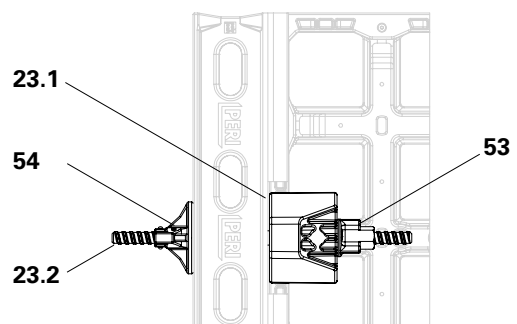

Fig. A3.08d

## DUO tube holders

The DUO tube holder (**24**) is used to assemble the DUO 62 compensation waler (**25**) and for aligning the DP panels with one or two steel tubes (**48 mm diameter**).

(Fig. A3.09)

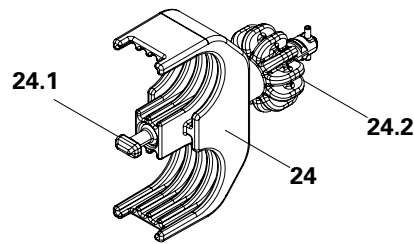

Fig. A3.09



Only ever tighten DW 15 (**24.2**) by hand!

### Installation

1. Position the DUO tube holder (**24**) on the steel tube (**48 mm diameter**) (**36**).
  2. Hook the DUO tube holder (**24**) into a connection point (**10.3**) of the DP panel with a cross tie bolt (**24.1**) and turn cross tie bolt (**24.1**) through 90°.
  3. Tighten the DUO tube holder (**24**) with the DW 15 grip (**24.2**).
- (Fig. A3.09a)

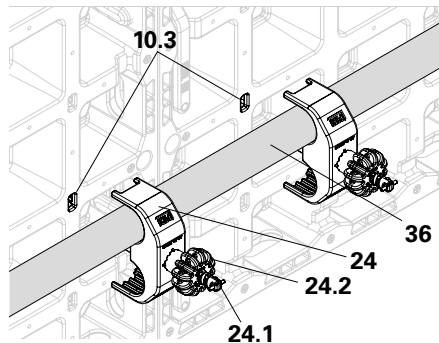

Fig. A3.09a



The DUO tube holder (**24**) is only correctly installed if the securing pin (**24.3**) has the same alignment as the connection points (**10.3**).

(Fig. A3.09b)



The DUO tube holder (**24**) can also be used to fix 2 scaffold tubes (**48 mm diameter**).

(Fig. A3.09c)

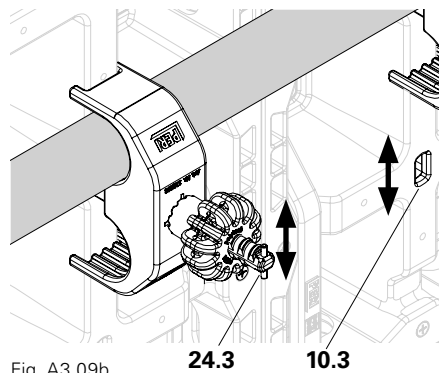

Fig. A3.09b

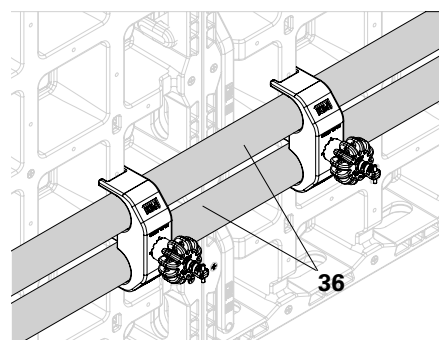

Fig. A3.09c

## DUO 62 compensation walers

The DUO 62 compensation waler (**25**) is used as a reinforcing, aligning and force-transmitting panel connection. (Fig. A3.10)



Only ever tighten the DW 15 grip (**24.2**) by hand!

Mount the DUO 62 compensation waler (**25**) at the level of the tie points (**10.1**).

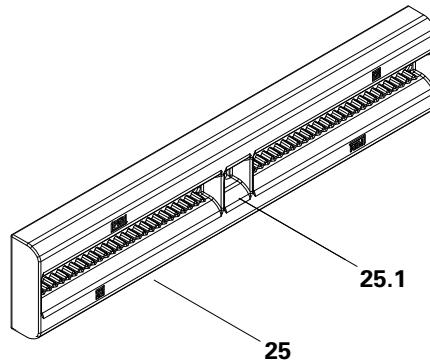

Fig. A3.10

If only one tie is used, it is to be pushed through the centre part (**25.1**) of the DUO 62 compensation waler (**25**).

## Assembly with DUO tube holders

### Used in:

- Length compensations up to 25 cm, see section B8 Length compensations
- Height extensions, see section B10 Height extensions

1. Position two DUO tube holders (**24**) onto a DUO 62 compensation waler (**25**). (Fig. A3.10a)

2. Hook the DUO tube holder (**24**) into a connection point (**10.3**) of the DP panel with a cross tie bolt (**24.1**) and turn cross tie bolt (**24.1**) through 90°.

3. Tighten the DUO tube holder (**24**) with the DW 15 grip (**24.2**). (Fig. A3.10a)

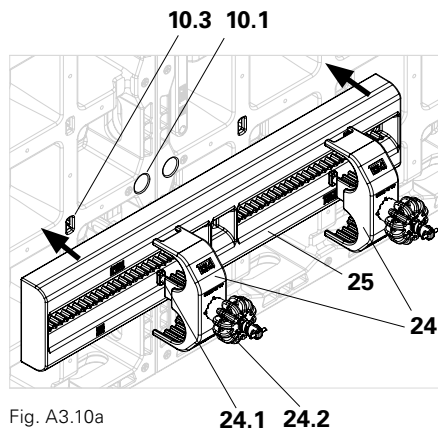

Fig. A3.10a



The DUO tube holder (**24**) is only correctly installed if the securing pin (**24.3**) has the same alignment as the connection points (**10.3**).

(Fig. A3.10b)

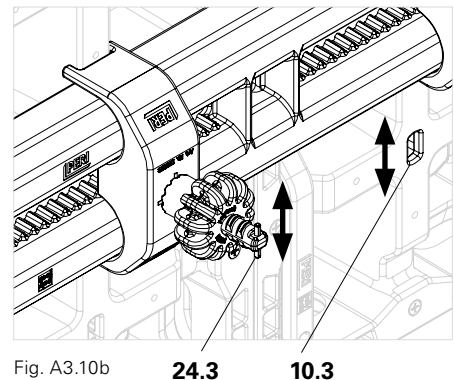

Fig. A3.10b

## Assembly with DUO corner tie and DW 15 wingnut counterplate

### Used in:

- Stopformwork, see section B9
- Stopend formwork

1. Insert the DUO corner tie (**23.2**) through the connector pocket at the required position.
  2. On the panel side, screw cam nut (**53**) onto the DUO corner tie (**23.2**).
  3. Place the DUO 62 compensation waler (**25**) on the DUO corner tie (**23.2**) and hold it securely.
  4. Screw the DW 15 wingnut counterplate (**54**) onto the DUO corner tie (**23.2**) by hand.
- (Fig. A3.10c + Fig. A3.10d)

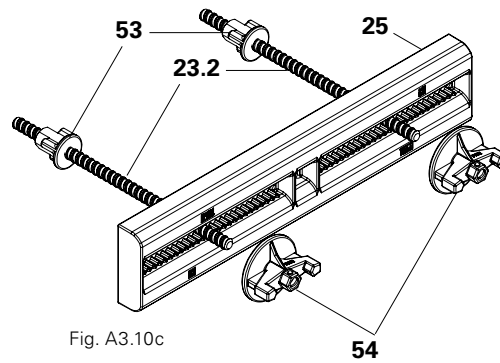

Fig. A3.10c

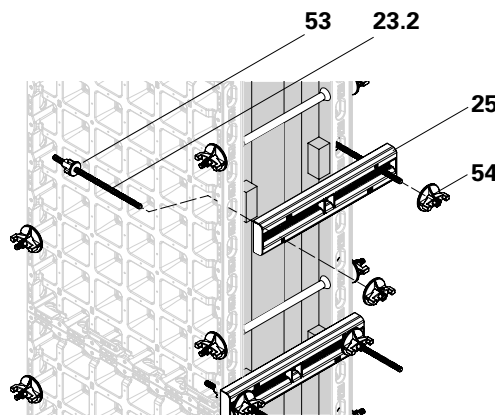

Fig. A3.10d

## DUO timber connector

### Assembly with DUO timber connectors

The DUO timber connector (60) is used to install one or two metal profiles measuring 50 x 50 mm or square timbers measuring 40 x 90 mm for aligning DP panels.  
(Fig. A3.11)

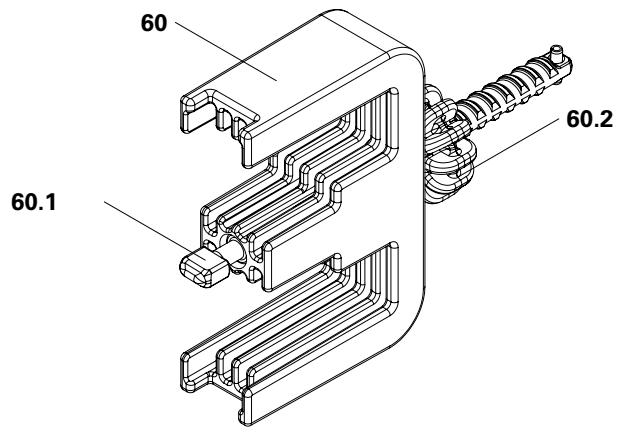

Fig. A3.11

### Assembly with 50 x 50 mm metal profiles

1. Position two DUO timber connectors (60) onto a 50 x 50 mm metal profile (61).
2. Hook the DUO timber connector (60) into a connection point (10.3) of the DP panel with a cross tie bolt (60.1) and turn the cross tie bolt (60.1) through 90°.
3. Tighten the DUO timber connector (60) with the DW 15 grip (60.2).  
(Fig. A3.11a)

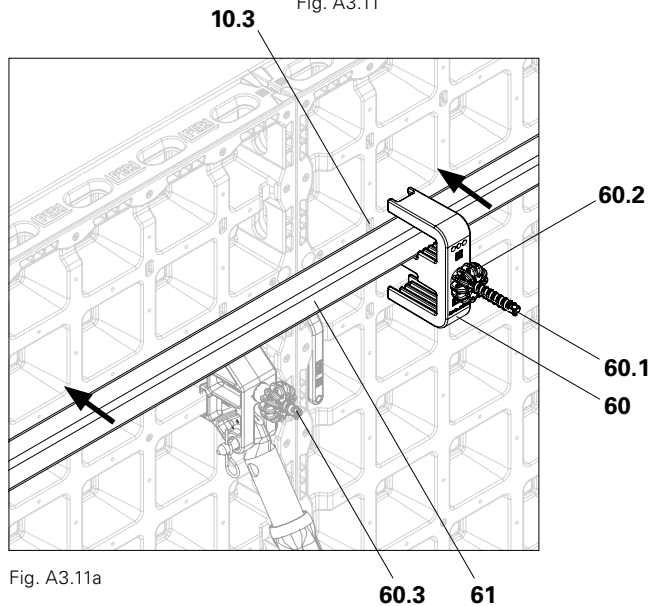

Fig. A3.11a



The DUO timber holder (60) is only correctly installed if the securing pin (60.3) has the same alignment as the connection points (10.3).



The DUO timber holder can also be used to affix 2 metal profiles measuring 50 x 50 mm.  
(Fig. A3.11b)

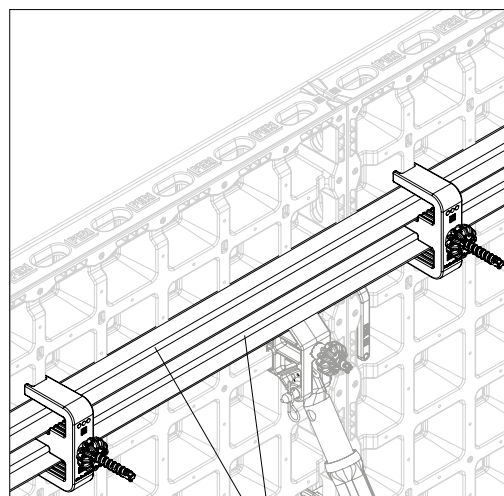

Fig. A3.11b

The distance between 2 50 x 50 mm metal profiles (61) makes it possible for a tie rod (50) and nut (54) or Wingnut Pivot Plates (56) to be installed.  
(Fig. A3.11c + Fig. A3.11f)

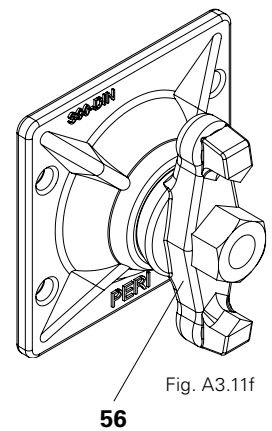
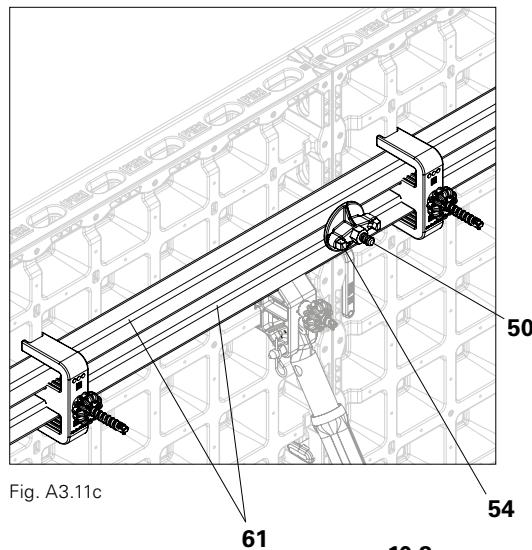

Fig. A3.11c

Fig. A3.11f

## Assembly with 40 x 90 mm square timbers

1. Position two DUO timber connectors (60) onto square timber measuring 40 x 90 mm (62).
2. Hook the DUO timber connector (60) into a connection point (10.3) of the DP panel with a cross tie bolt (60.1) and turn the cross tie bolt (60.1) through 90°.
3. Tighten the DUO timber connector (60) with the DW 15 grip (60.2).  
(Fig. A3.11d)

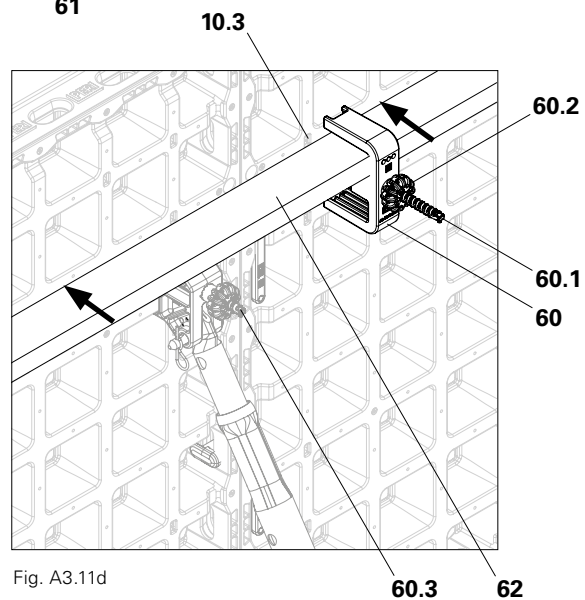

Fig. A3.11d



The DUO timber holder (60) is only correctly installed if the securing pin (60.3) has the same alignment as the connection points (10.3).  
(Fig. A3.11d)



The DUO timber holder (60) can also be used to affix 2 square timbers measuring 40 x 90 mm (62).  
(Fig. A3.11e)

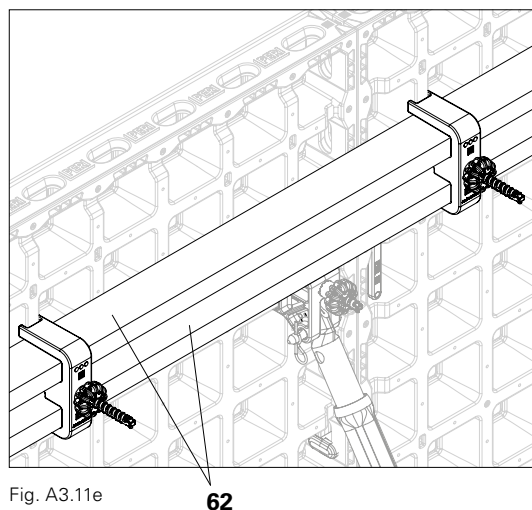

Fig. A3.11e

The distance between 2 square timbers makes it possible for a tie rod (50) and nut (54) or Wingnut Pivot Plates (56) to be installed.  
(Fig. A3.11g)

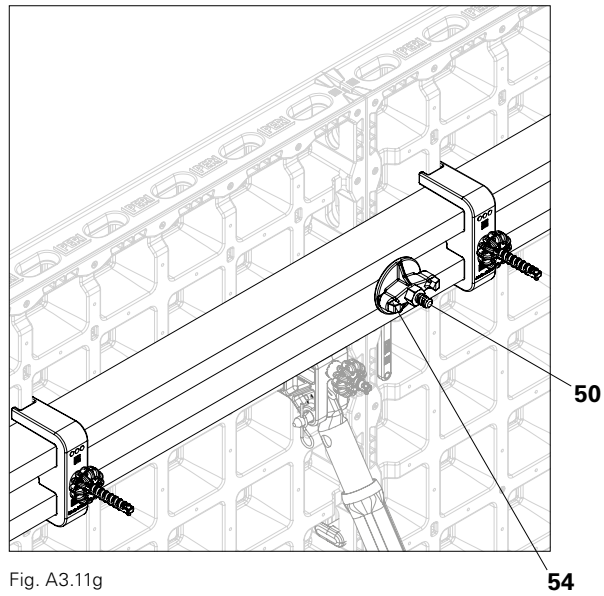

Fig. A3.11g

## DUO frame holders

The DUO frame holder (**41**) is used:

- for realising tie connections outside of the DP panel, see section B11 Foundations,
- as protection against lifting of formwork elements,
- instead of kicker braces.

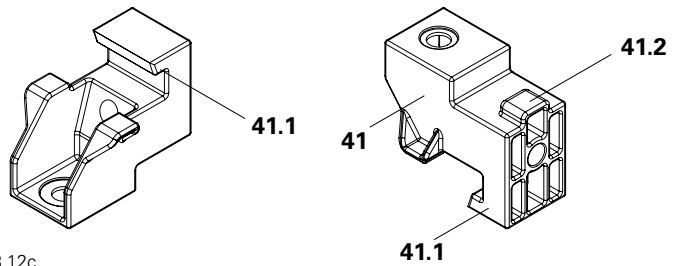

Fig. A3.12c

### Assembly as tie connections

1. Attach the hooks (**41.1**) of the DUO frame holder (**41**) to the frame profile of the DP panel.
2. Insert the tie rod (**50**) through the frame holder.
3. Tighten the tie rod with the DW 15 wingnut counterplate (**54**). (Fig. A3.12 + Fig. A3.12c)

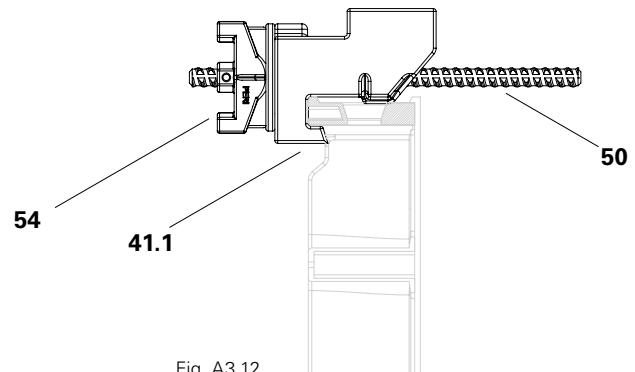

Fig. A3.12

### Assembly as protection against lifting or as a replacement for kicker braces

1. Drill hole for anchor bolt in sufficiently load-bearing ground. (Fig. A3.12b)
2. Attach the lug (**41.2**) of the DUO frame holder (**41**) to the connector pocket of the DP panel. (Fig. A3.13)
3. Affix the DUO frame holder (**41**) using the PERI anchor bolt 14/20 x 130, art. no. 124777 (**30.1**). Take the Technical Data Sheet into consideration!

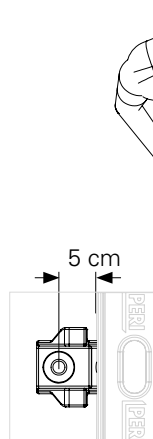

Fig. A3.12a

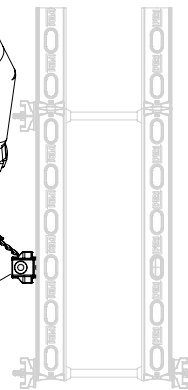

Fig. A3.12b

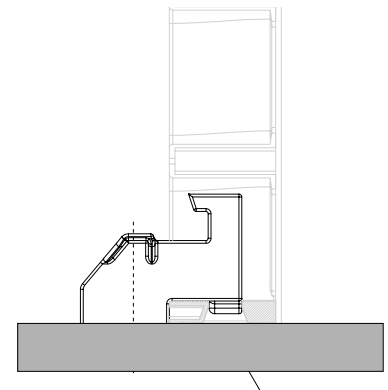
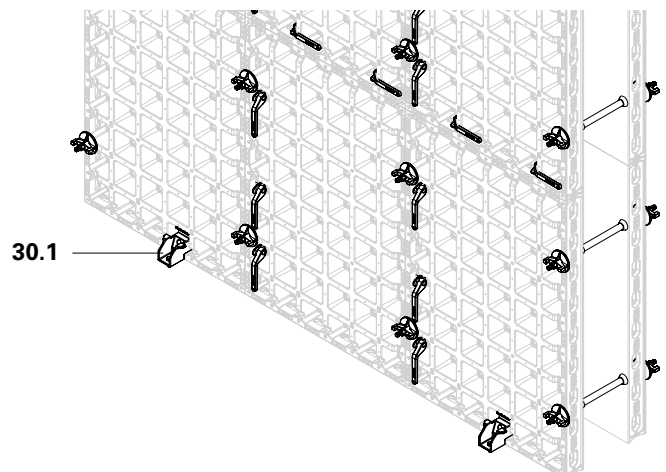

Fig. A3.13



## DES extension supports



### Warning

The component may end up being subjected to excessive loads!

The component could collapse!

- ⇒ Only use the extension support on the top side of the DUO formwork!
- ⇒ Do not use the extension support as a filler support for wall length compensations!

With the DES extension support (40), DUO formwork can be combined with conventional plywood, e.g. for height offsets, see section B10 Height extensions.

The DES extension support (40) is available for 12, 15 and 18 mm plywood.

(Fig. A4.01)

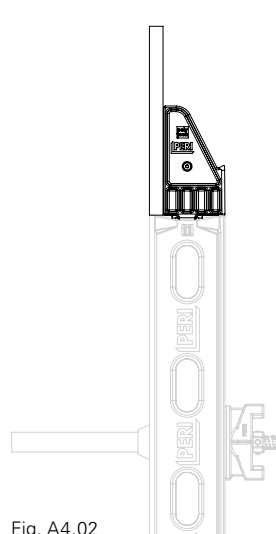
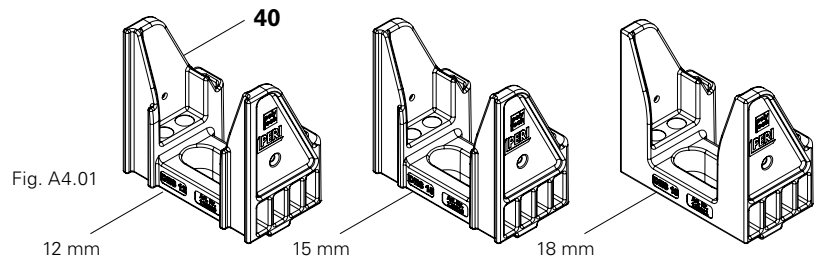

Fig. A4.02

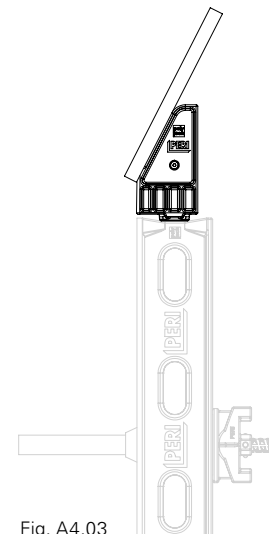

Fig. A4.03

### Application possibilities

- As height compensation for formwork elements (Fig. A4.02)
- as a filler funnel (Fig. A4.03)

### Installation

1. Insert a 50 x 50 x 120 mm timber inlay (91) into the DES extension support (40), and secure with Torx screws 5 x 15 (94).
2. Affix to the DP panel, DMP multi panel or DFP filler panel with the DUO coupler.
3. Screw the filler plate (90) tightly onto the timber inlay using at least two 5 x 40 Torx screws (94):
  - as height compensation on the straight side (40.1), (Fig. A4.06)
  - as filler funnel on the chamfered side (40.2). (Fig. A4.07)

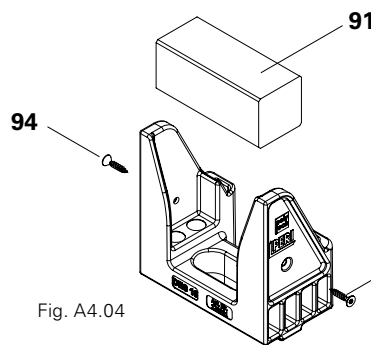

Fig. A4.04

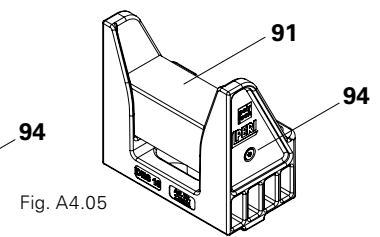

Fig. A4.05

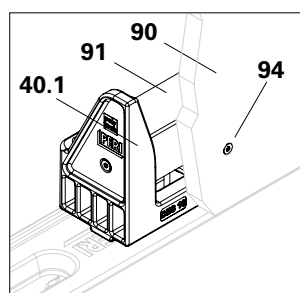

Fig. A4.06

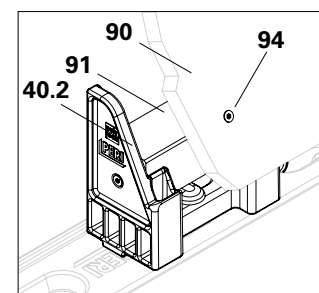

Fig. A4.07

## DUO stripping levers

The DUO stripping lever (**44**) has been developed to simplify the striking process. It engages with the DUO panel frame, providing a lever that will remove fixed DP panels from the concreted wall. The individual parts of the stripping lever are as follows:

- rear handle (**44.1**),
- lever end (**44.2**) and
- hand grip (**44.3**).

(Fig. A4.08)

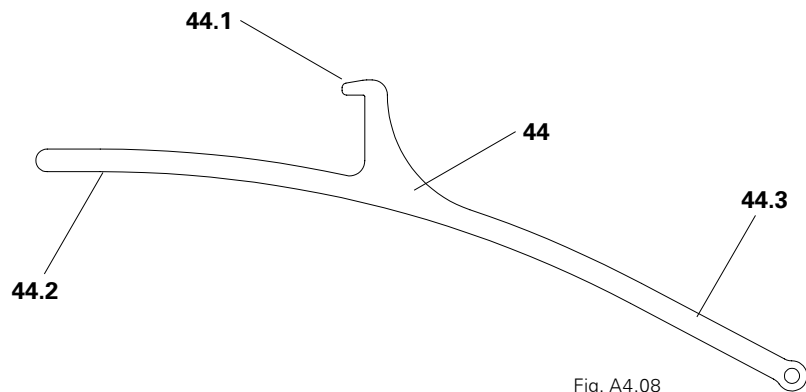

Fig. A4.08

### Use

1. Prior to striking, remove the DUO coupling tie (**22**) and DUO coupler (**21**) from the vertical formwork joint in order to remove up to 2 DUO DP panels (**10**) at the same time.
2. Insert the rear handle of the stripping lever (**44.1**) through the perforation on the edge of the panel. Ensure that the rear handle is sitting in the correct position on the DP panel.
3. Pull away from the wall using the hand grip of the stripping lever (**44.3**) in order to release the DP panels from the wall.

(Fig. A4.09 – Fig. A4.09b)

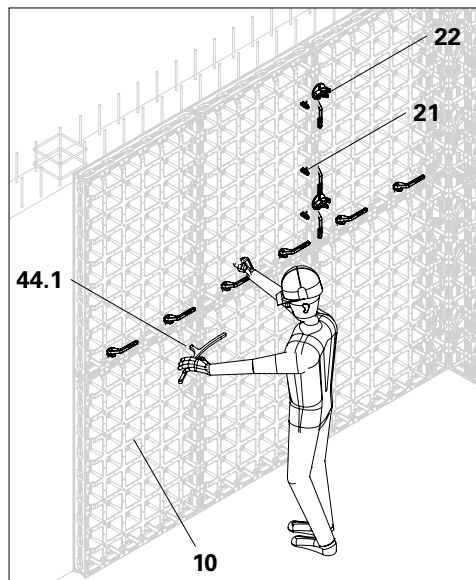

Fig. A4.09

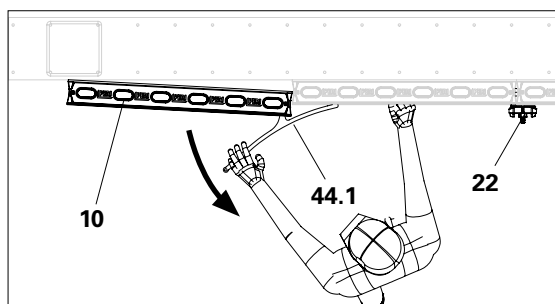

Fig. A4.09b

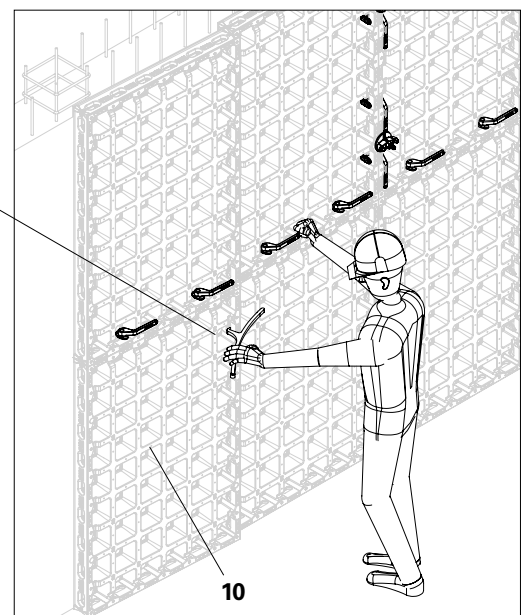

Fig. A4.09a

If you are required to remove a single DP panel (**10**) from the formwork (e.g. in case of manual transfer, monolithic formwork), the DUO stripping lever (**44**) can also be placed at the upper end of the DUO DP panel.

1. Remove all DUO coupling ties (**22**) and DUO couplers (**21**) from the DP panel.
2. Insert the rear handle (**44.1**) of the DUO stripping lever through the perforation on the upper or lower edge of the panel. Ensure that the rear handle (**44.1**) is sitting in the correct position on the DP panel.
3. Pull away from the wall using the hand grip (**44.3**) of the DUO stripping lever (upwards or downwards depending on how the lever has been inserted) in order to release the DP panels from the wall.

(Fig. A4.09c + Fig. A4.09d)

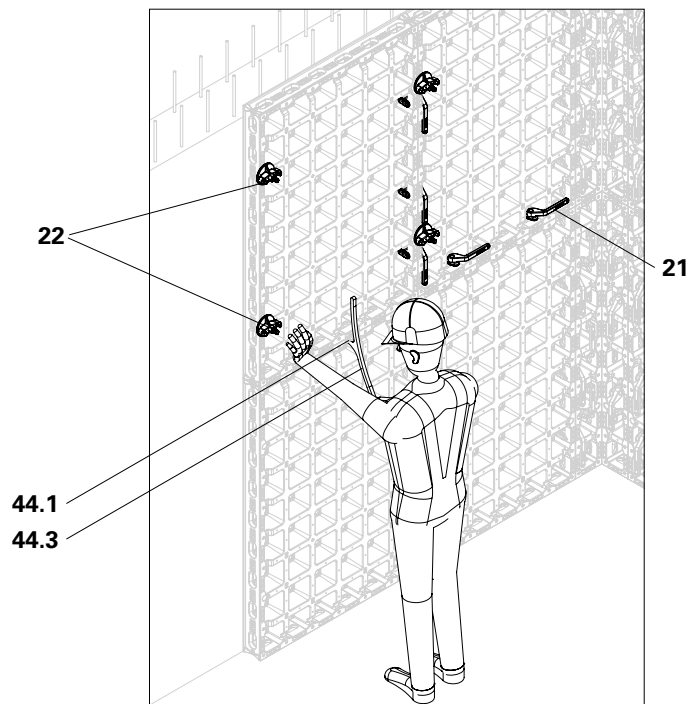

Fig. A4.09c

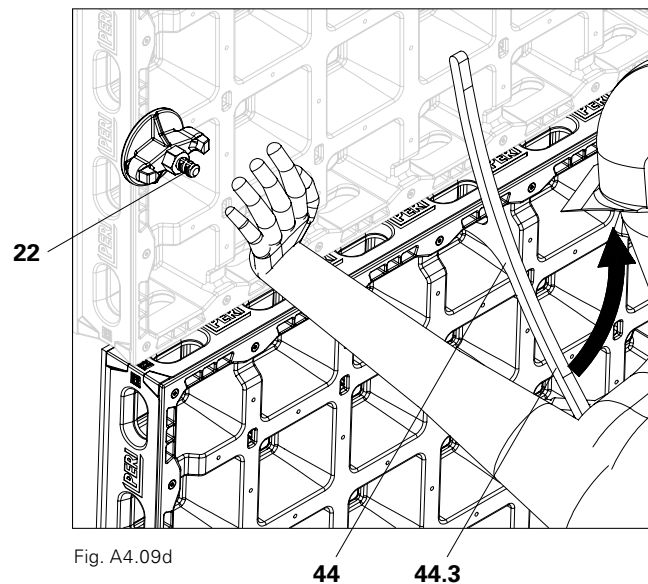

Fig. A4.09d

If it is not possible to lever out the DP panel (10) from a neighbouring DP panel, e.g. in the corner area, the DUO stripping lever (44) can also be positioned at the free side of the DP panel.

1. Prior to striking, remove the DUO coupling tie\* and DUO coupler (21) from the vertical formwork joint in order to remove up to 2 DUO DP panels (10) at the same time.
2. Insert the end (44.2) of the DUO stripping lever (44) through the perforation on the edge of the panel so that the rear handle (44.1) is pointing towards the wall. Make sure that the rear handle makes contact with the concreted wall.
3. Push the hand grip (44.3) of the DUO stripping lever (44) towards the wall in order to release the DP panel (10) from the wall.

(Fig. A4.09e + Fig. A4.09f)

\*Not shown in the illustration

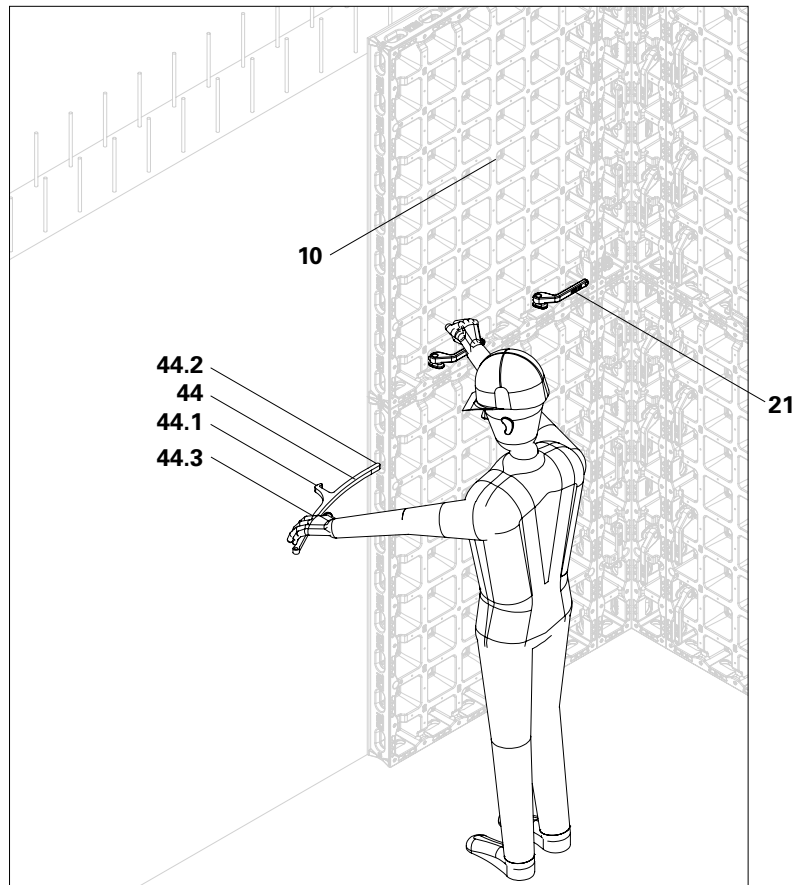

Fig. A4.09e



If the concrete has not hardened completely, clamp a timber block between the concreted wall and the stripping lever to prevent impressions from appearing in the concrete.

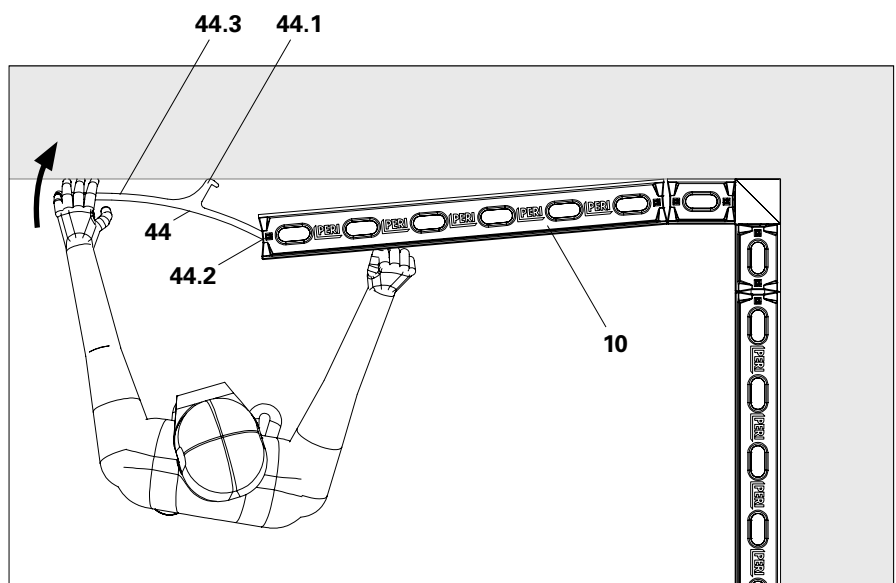

Fig. A4.09f

## DUO Crane Eyes



### Warning

Heavy suspended components!  
Components may fall down and cause serious injuries when they are being moved by crane!

- ⇒ Do not stand under suspended loads!
- ⇒ Take into account the permissible load-bearing capacity of the DUO crane eye of 200 kg and the crane capacity!
- ⇒ Follow the Instructions for Use for the DUO crane eye!

The DUO crane eye is not used in continuous operations and, after being mounted, becomes an integral part of the load.

### Installation

Insert the crane eye (**28**) into the connector pocket (**10.2**) of the DP panel, press down and turn through 90°.  
(Fig. A4.10 + Fig. A4.11)

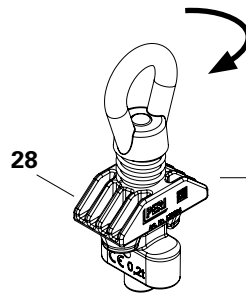

Fig. A4.10

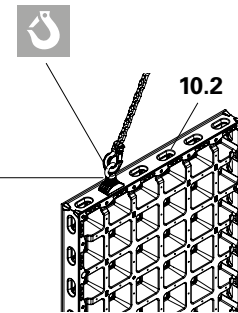
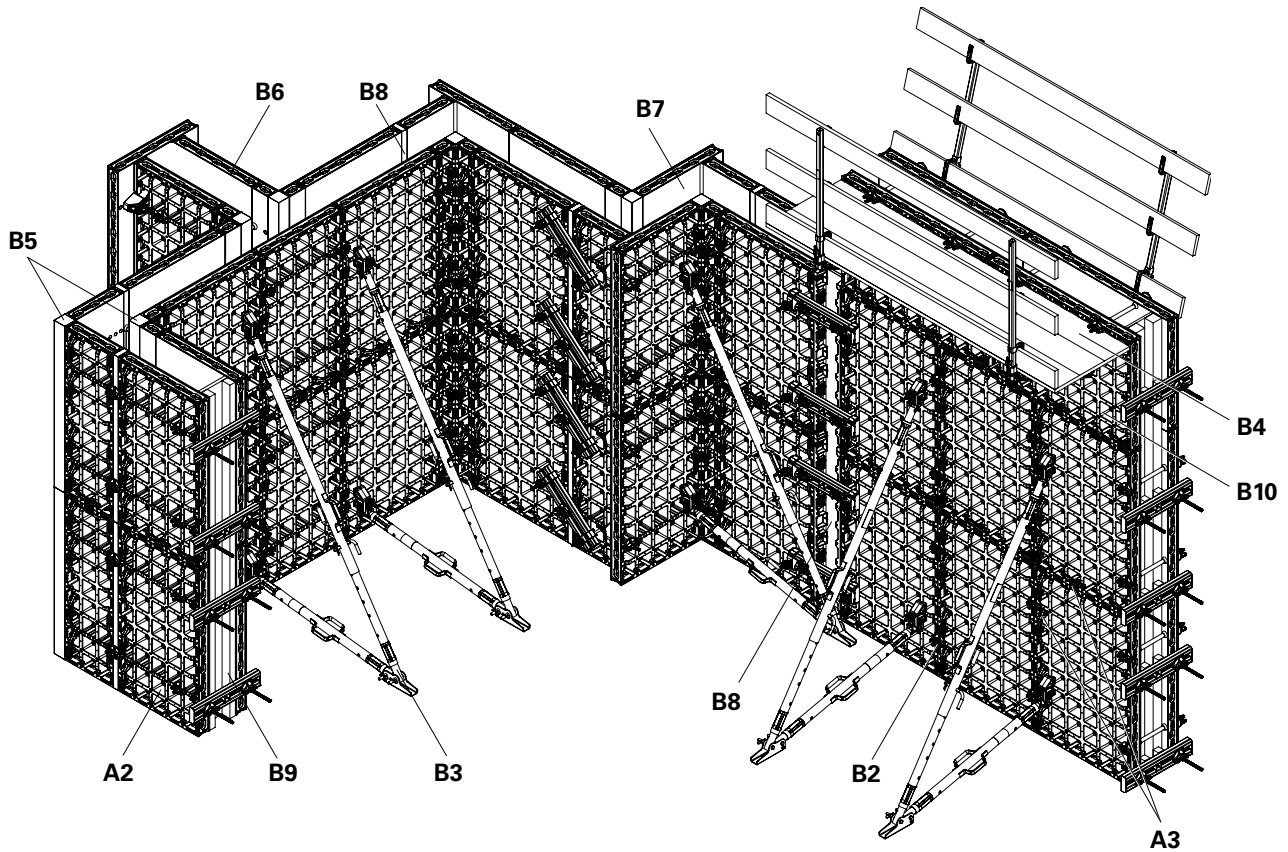

Fig. A4.11

## Overview



### Wall formwork

B1	Safety instructions	41	90° corners	72
	Quick user guide	42	Corner panels	74
	Assembly without a crane	42	Height extensions using DP 60 panels	76
	Assembly with a crane	45	Height extensions using filler panels	78
	LIWA DUO adapters	48	Alternative formwork for external corners	80
	Layout of the LIWA LRS locks (using LIWA DUO adapters)	50	B6 T-junctions, wall connections	81
	DOMINO DUO adapters	52	Obtuse-angle wall connections	82
	Layout of the DOMINO DRS locks (using DOMINO adapters)	53	B7 Wall offsets	83
	SB-DUO hook straps	56	B8 Length compensation	88
B2	Anchor technology	60	B9 Stopped formwork	92
B3	Push-pull props	61	B10 Height extensions	96
	DUO brace connectors	61	Height offsets	96
	Push-pull props and kicker braces	61	Height extensions using DP 135 panels	97
	Table of PERI push-pull props and kicker braces	62	– using DP 60 panels	98
B4	Working and concreting scaffolds	64	– using DFP filler panels	99
	DUO scaffold brackets	64	– using DES extension supports	100
	DUO front post holders	65	B11 Foundations	101
	Assembly at internal corners	68	– using DP panels	101
	Assembly in case of height extensions	69	– using DMP multi panels	102
B5	Corners	70	– using DP 60 panels	103
	DC corner posts	70	– using DUO frame holders	104
			– using DUO foundation tie clamps	105

## System-specific

### General

Do not exceed the permissible fresh concrete pressure.

Retract components only when the concrete has sufficiently hardened and the person in charge has given the go-ahead for striking to take place.

Only use PERI lifting accessories.

During striking, do not tear off the formwork elements with the crane.

Check the usability by referring to the production date. Remove and dispose of components that have exceeded the period of usability.

Anchoring is to take place only if the anchorage has sufficient concrete strength.

### Wall system, column system

If a storm warning is issued, additional push-pull props are to be attached or other bracing measures are to be carried out along with implementing the details contained in the PERI Design Tables.

## Notes on illustrations

The structures presented in these Instructions for Assembly and Use are shown in the form of examples with only one component size. Instructions on vertical applications refer to a construction height of 2.70 m. They are valid for all component sizes contained in the standard configuration.

To facilitate understanding, detailed illustrations are sometimes incomplete. The safety installations which have possibly not been shown in these detailed illustrations must nevertheless be available.

## Assembly without a crane

### Panels



#### Warning

Heavy components!  
Components may fall down while they are being carried or may tilt during striking and cause injuries!

- ⇒ Take into account the weight of two connected DP panels. Have DP panels transported/carried by two persons.
- ⇒ Secure DP panels against tilting and wind forces!



Fig. B1.01

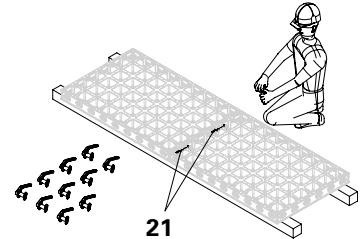
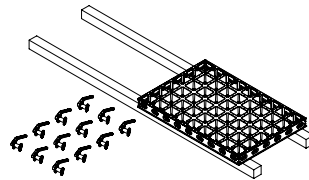

Fig. B1.01a

### Installation

1. Prepare DP panels for assembly. Lay out square timbers or planking as a base. The assembly area must be even! (Fig. B1.01)
2. Position two DP panels with the formlining facing downwards and connect them at the short panel joint using DUO couplers (21). (Fig. B1.01a)
3. Two persons are required to transport the panel unit to the place of operation (Fig. B1.02 + Fig. B1.02a).

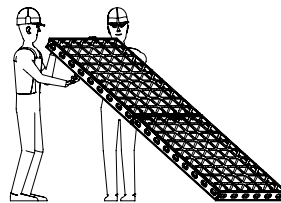

Fig. B1.02

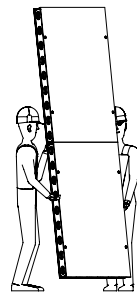

Fig. B1.02a



Do not set down loads on connected panels.

### Primary formwork

#### Installation

1. Mount the DUO brace connector (27), see section B3. (Fig. B1.03)
2. Install push-pull props (38 + 39) according to permissible width of influence. (Fig. B1.04)
3. Mount push-pull props on the base plate.
4. Affix the base plate with an anchor bolt.

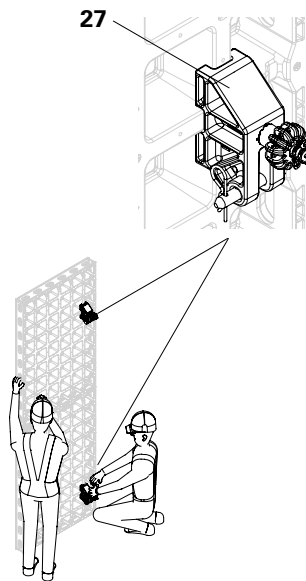

Fig. B1.03

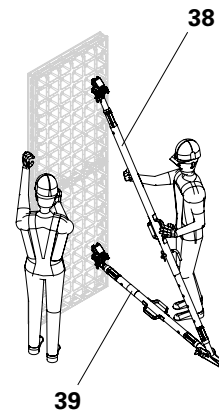

Fig. B1.04

5. Place the second panel unit next to it. (Fig. B1.05)
6. Connect both panel units at the vertical joint using DUO couplers (21). (Fig. B1.06)
7. Repeat steps 3 and 4 until the desired component length has been reached.
8. Install push-pull props (38, 39) continuously according to the applicable width of influence. (Fig. B1.07)

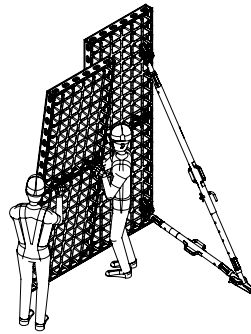

Fig. B1.05

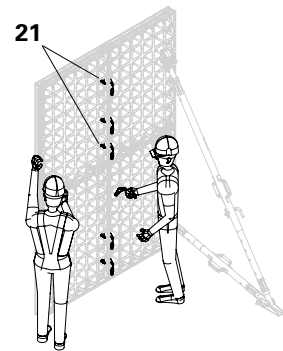

Fig. B1.06

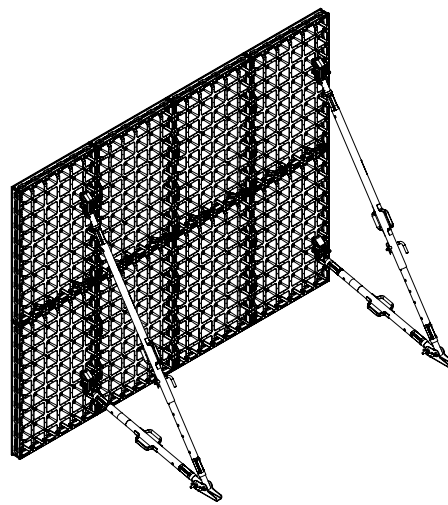

Fig. B1.07

## Closing formwork

### Installation

1. Install the closing formwork in the same way as the primary formwork. (Fig. B1.07)
2. Place the closing formwork in front of the primary formwork.
3. Mount ties, see section A3 Panel connections.

## Connecting the formwork

### Installation

1. Install the DUO 70 scaffold bracket (70) and DUO front post holders (73) (Fig. B1.08), see section B4 Working and concreting scaffolds.
2. Install planking and ladder cage.

## Concreting



From a safe and secure working platform (Fig. B1.08)

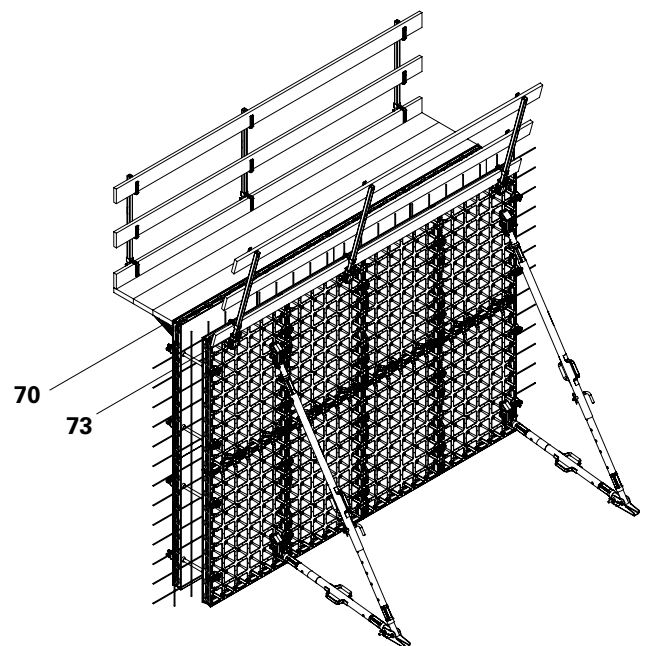

Fig. B1.08

## Striking



### Warning

Heavy components!

Components may fall down while they are being carried or may tilt during striking and cause injuries!

- ⇒ Retract components only when the concrete has sufficiently hardened and the person in charge has given the go-ahead for striking to take place.
- ⇒ Take into account the weight of two connected panels. Have panels transported/carried by two persons.
- ⇒ Secure DP panels against tilting and wind forces!

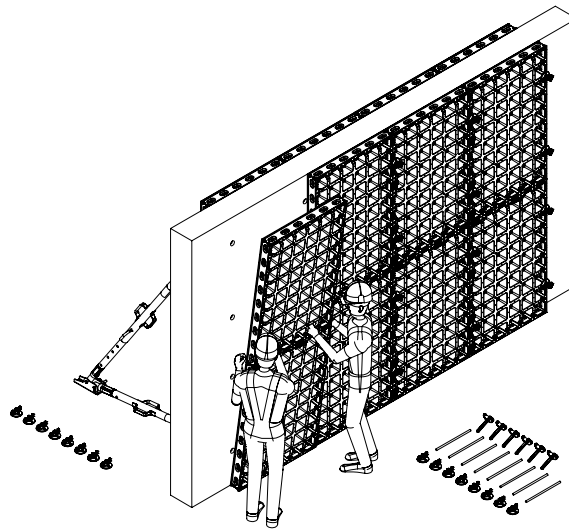

Fig. B1.09

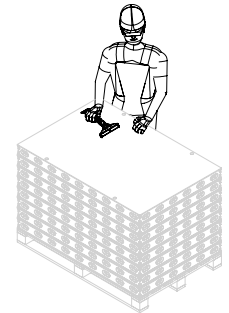

Fig. B1.10

## Dismantling

1. Remove safety devices, e.g. working and concreting scaffolds or protection against lifting.
2. Dismantle the push-pull prop.
3. At the vertical joint, loosen ties, DUO couplers or other panel connections that have to be removed in order to dismantle a panel unit. (Fig. B1.09)
4. Move, clean and transfer panel unit to the next place of operation. (Fig. B1.10)

Cleaning see section E1 Cleaning and maintenance.

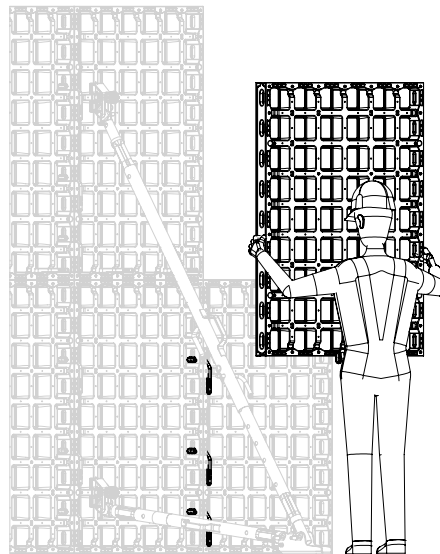

Fig. B1.10a



As an alternative to the method with two persons, the individual DP panels can also be dismantled and transported one after the other by one person. (Fig. B1.10a)



### Warning

Heavy components!

Components may fall down while they are being carried or may tilt during striking and cause injuries!

- ⇒ Only remove the DUO couplers and the ties of the individual DP panel.

## Assembly with a crane

### Panels



#### Warning

Heavy components!

Components may fall down while they are being carried or may tilt during striking and cause injuries!

- ⇒ Only remove crane eyes once the push-pull prop has been dowelled.
- ⇒ Take into account the weight of two connected DP panels. Have panels transported/carried by two persons.
- ⇒ Secure DP panels against tilting and wind forces!



Fig. B1.11

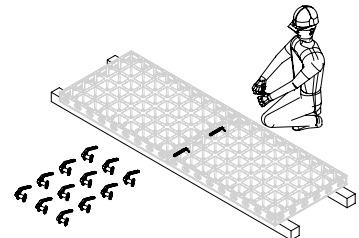
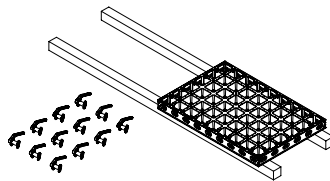

Fig. B1.11a

### Installation

1. Prepare DP panels for assembly. Lay out square timbers or planking as a base. The assembly area must be even! (Fig. B1.11)
2. Position two DP panels with the formlining facing downwards and connect them at the short panel joint using DUO couplers (21) to form a single panel unit. (Fig. B1.11a)
3. Place a second panel unit next to the first panel unit and connect them at the long joint using DUO couplers (20). (Fig. B1.12 + Fig. B1.13)
4. Repeat step 3 until the required component length has been reached. (Fig. B1.14)

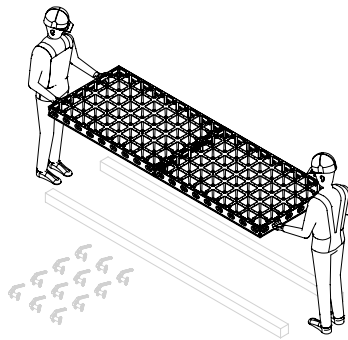

Fig. B1.12

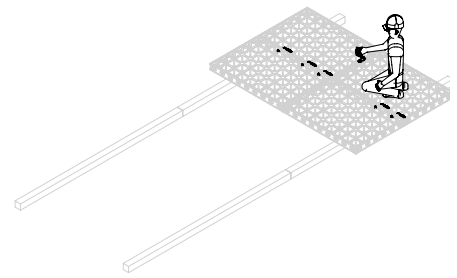

Fig. B1.13

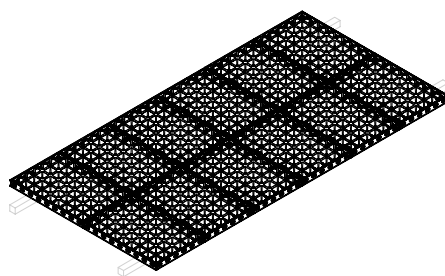

Fig. B1.14

## Primary formwork

### Installation

1. Install the DUO brace connector (27).
2. Install push-pull props according to the applicable width of influence. (Fig. B1.15)
3. Repeat steps 1 and 2 until the primary formwork is sufficiently stabilised. (Fig. B1.16)

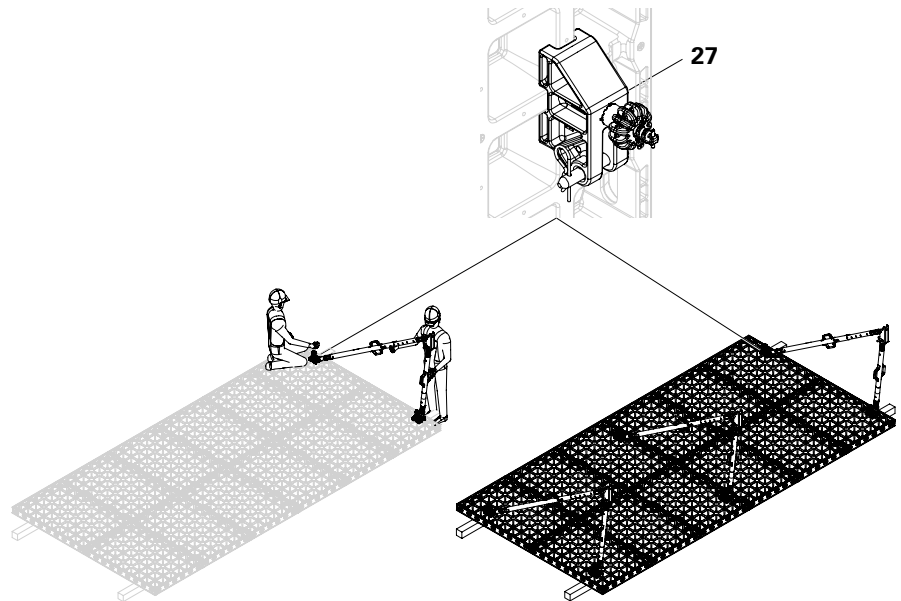

Fig. B1.15

Fig. B1.16

## Moving by crane



### Warning

Heavy suspended components!  
Components may fall down and cause serious injuries when they are being moved by crane!

- ⇒ Do not stand under suspended loads!
- ⇒ Concrete strength must be taken into account!
- ⇒ Secure DP panels against tilting and wind forces!
- ⇒ Take into account the permissible load-bearing capacity of the DUO crane eye of 200 kg and the crane capacity!
- ⇒ Follow the Instructions for Use for the DUO crane eye!

### Installation

1. Insert the DUO crane eye (28) into the connector pocket (10.2) of the DP panel, press down and turn through 90°. Up to 12 DP panels can be moved. (Fig. B1.17)
2. Suspend the primary formwork from a crane and transport it to place of operation. (Fig. B1.18)

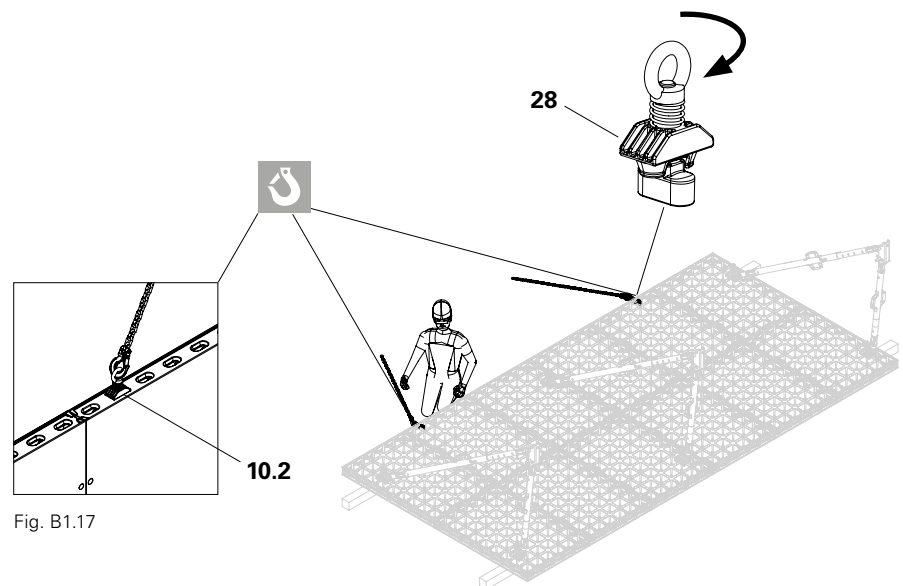

Fig. B1.17

## Closing formwork

### Installation

1. Install the closing formwork in the same way as the primary formwork. (Fig. B1.11 – Fig. B1.14)
2. Place the closing formwork, which is suspended from the crane, in front of the primary formwork. (Fig. B1.18)

## Connecting the formwork

### Installation

1. Install ties.
2. Install the DUO 70 scaffold bracket and DUO front post holders, see section B4 Working and concreting scaffolds.
3. Install planking and edge protection.

### Concreting



From a safe and secure working platform.

### Striking



From a safe and secure working platform.



### Warning

Heavy suspended components!  
Components may tilt during striking or may fall down when they are being moved by crane and cause serious injuries!

- ⇒ Do not stand under suspended loads!
- ⇒ Concrete strength must be taken into account!
- ⇒ Secure DP panels against tilting and wind forces!
- ⇒ Take into account the permissible load-bearing capacity of the DUO crane eye of 200 kg and the crane capacity!
- ⇒ Follow the Instructions for Use for the DUO crane eye!
- ⇒ Only release crane hooks once the push-pull prop has been dowelled.

### Dismantling

1. Remove safety devices.
2. Attach crane to DUO crane eye.
3. Remove ties.
4. At the vertical joint, loosen ties, DUO couplers or other panel connections that have to be removed in order to dismantle a panel unit.
5. Move, clean and transfer the panel unit to the next place of operation. (Fig. B1.19) Cleaning see section E1 Cleaning and maintenance.

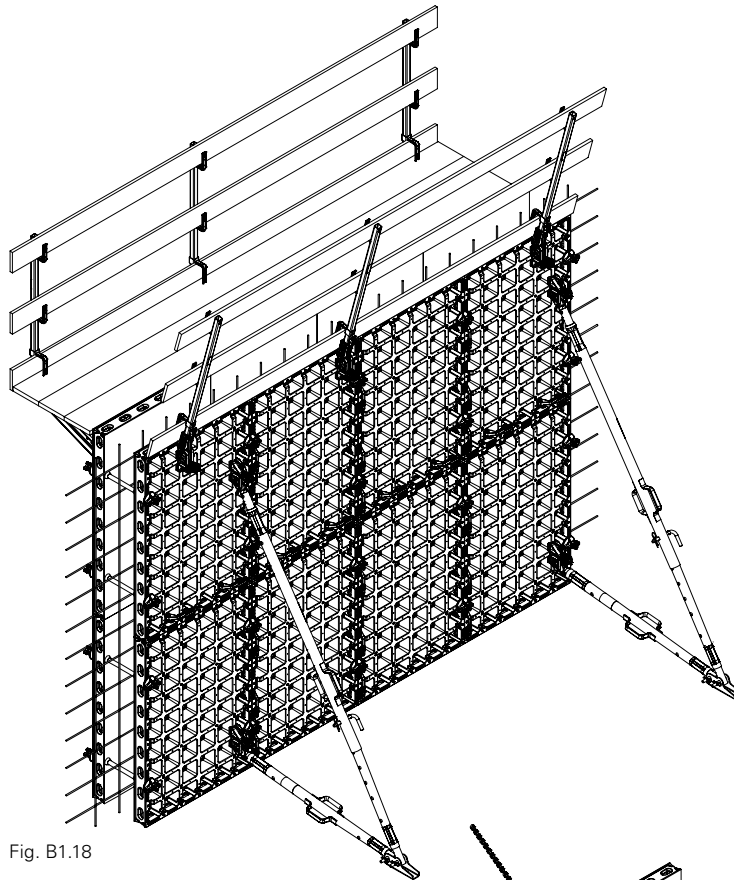

Fig. B1.18

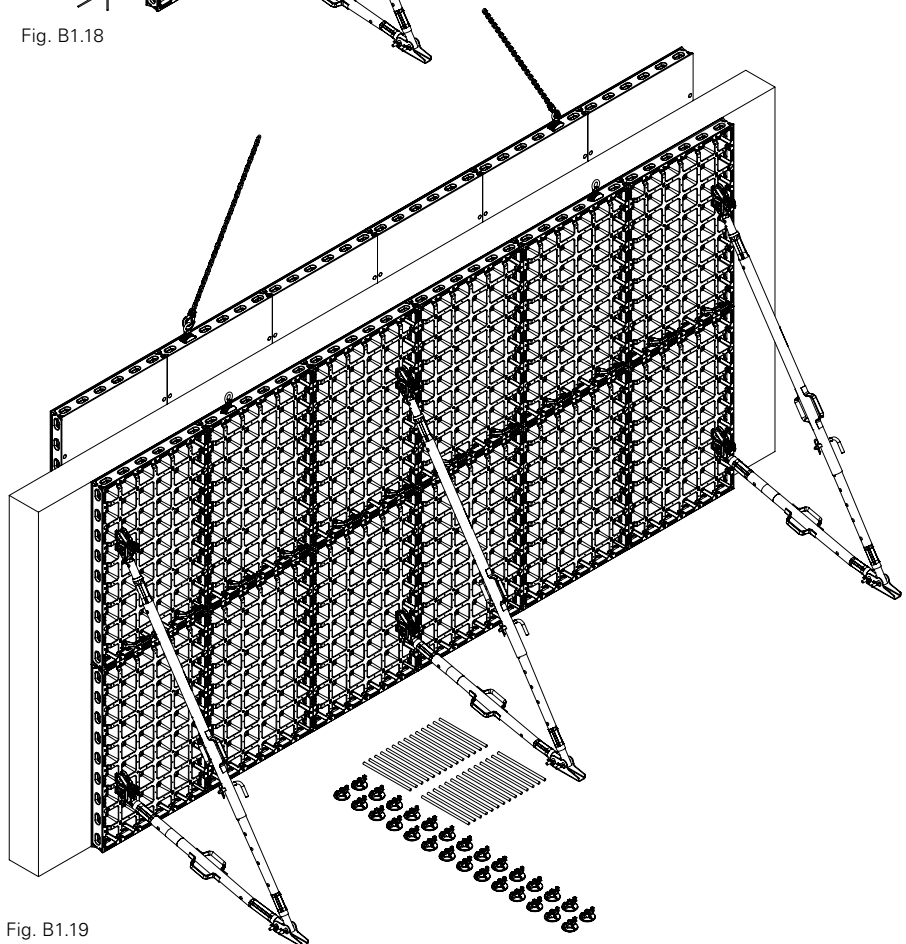

Fig. B1.19

## LIWA DUO adapter



The maximum permissible fresh concrete pressure is 50 kN/m<sup>2</sup>

### Components

- 64** LIWA wedge clamp compensation (117677)
- 65** LIWA LRS alignment coupler (127460)
- 69.1** LIWA 150 articulated corner (117275)
- 69.2** LIWA 250 articulated corner (124006)
- 69.3** LIWA 300 articulated corner (117209)

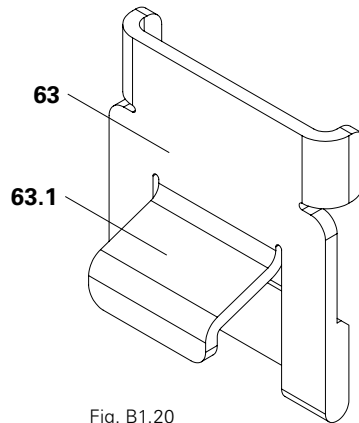

Fig. B1.20

The LIWA DUO adapter (**63**) makes it possible to connect the LIWA articulated corner to the DUO DP panel.

The adapter has a tie (**63.1**) that secures the frame profile of the DP panel (**10.9**) in the connector pocket. (Fig. B1.20)

The adapter tie (**63.1**) must be positioned in such a way that it is pointing away from the formlining (**10.7**). (Fig. B1.21)

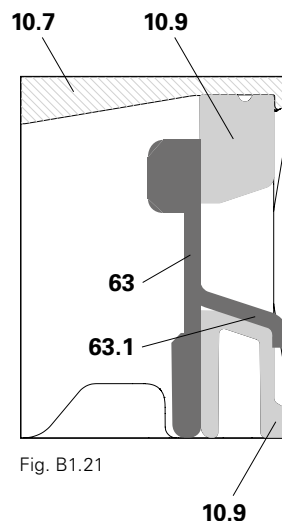

Fig. B1.21

The LIWA DUO adapter can be used with the LIWA wedge clamp compensation (**64**) and LIWA LRS alignment coupler (**65**).  
(Fig. B1.22 + Fig. B1.23)

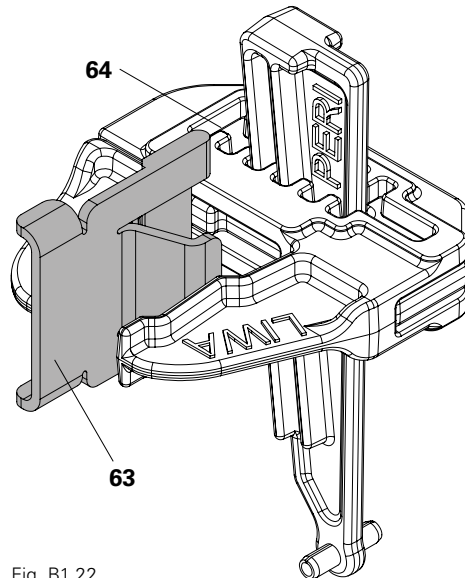

Fig. B1.22

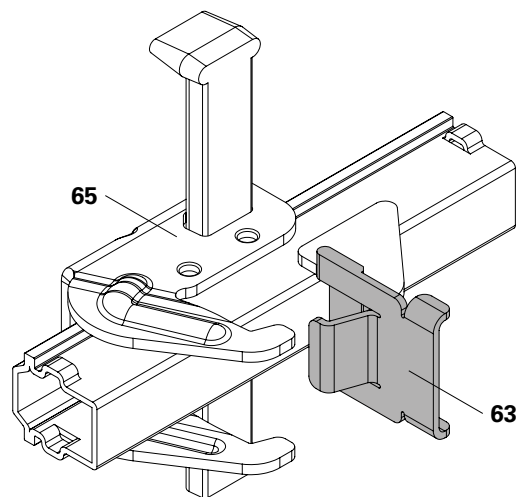

Fig. B1.23

## Layout of the LIWA LRS locks (using LIWA DUO adapters)

### Internal formwork

On the internal formwork, two LIWA locks (LIWA wedge clamp compensation (64) or LIWA LRS alignment coupler (65)) are required for each DP 135 panel (10). If the DWC wall thickness compensator  $\geq 7$  cm (13) is used, then the DUO 62 compensation waler must be used.

Four DUO couplers (21) must be installed for each DUO DP 135 panel (10) along the vertical joint.

(Fig. B1.24)

If the DUO couplers (21) get in each other's way, then they will need to be offset from one another on the left and right formwork side.

### External formwork

If there is a requirement for compensation, square timber (91) with a thickness of up to 5 cm can be mounted next to the LIWA articulated corner (69). This allows for the use of tie rods at right angles to the DUO formwork. The following elements are always required for the external formwork:

- 4x LIWA wedge clamp compensation (64) per DP 135 panel (10)
- 2x LWR walers (80.1) per DP 135 panel (10).

If the parts get in each other's way (e.g. locks and walers), then the locks can be mounted on the next adjacent strut.

Four DUO couplers (21) must be installed for each DUO DP 135 panel along the vertical joint. LWR walers are installed to cover the joint between the LIWA articulated corner (69) and the DUO panels (10). (Fig. B1.25)

**Angle  $\alpha \leq 120^\circ$ :**

**The external formwork must be stiffened with LWR 170 walers (80.2) (art. no.: 125473).**

**Angle  $\alpha > 135^\circ$ :**

**The external formwork must be stiffened with LWR 80 walers (80.1) (art. no.: 118380).**

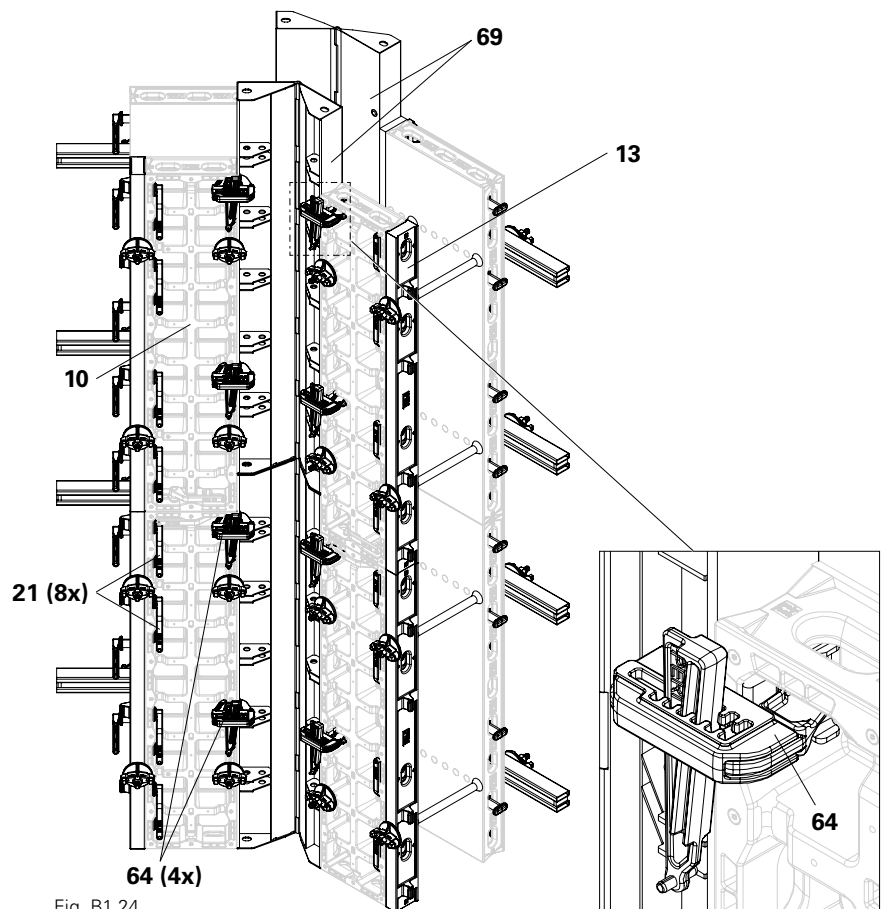

Fig. B1.24

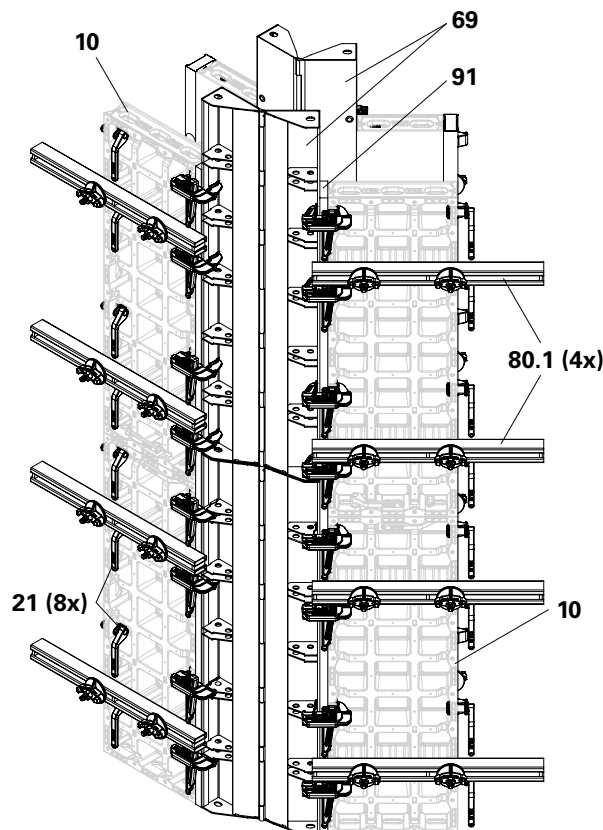

Fig. B1.25

## Layout of the LWR walers (80.1) or LWR 170 walers (80.2) on the external formwork

X = centimetre-based square timber compensations (up to 5 cm) can be re-  
realised.



- Angle  $\alpha \leq 120^\circ$ : The external formwork must be stiffened with LWR 170 walers (80.2), art. no.: 125473.
- Angle  $\alpha > 135^\circ$ : The external formwork must be stiffened with LWR 80 walers (80.1) or longer walers, art. no.: 118380.

PERI LWR 80 walers (80.1) or LWR 170 walers (80.2) are installed in such a way that they overlap the LIWA articulated corner (69) by at least 25 mm so that the joint between the panels is covered. The number of joints depends on the waler length used. (Fig. B1.26)

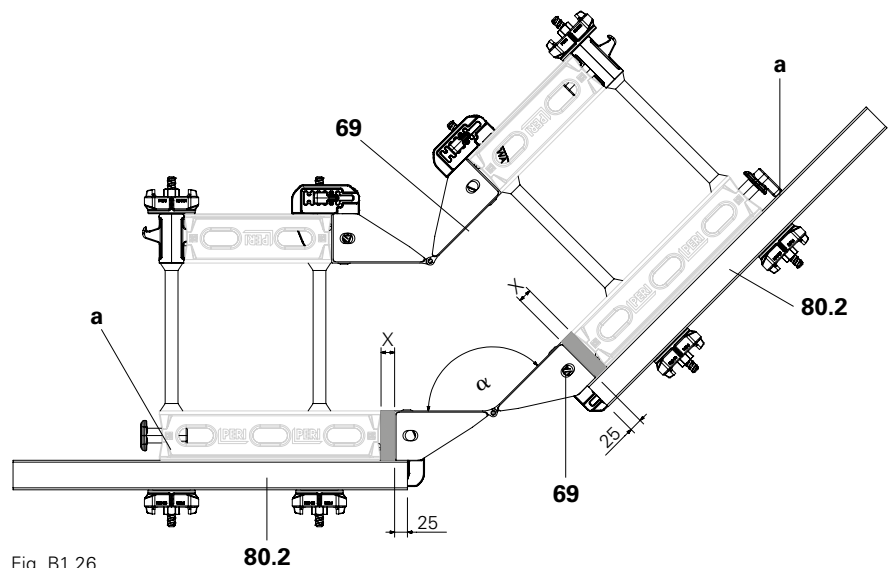

Fig. B1.26

### Components required

In combination with the LIWA articulated corner (69), angles between  $75^\circ$  and  $165^\circ$  and wall thicknesses between 15 cm and 40 cm can be concreted. (Tab. B1.01)

The LIWA wedge clamp compensation (64) is installed from bottom to top, both for external and internal corners.

Angle $\alpha$	Formwork side	Wall thickness [cm]					
		15	20	25	30	35	40
75°	Outside	DMP 75 + DWC 5	2 cm + DMP 75	4 cm + DMP 75	DMP 75	2 cm + DMP 75	3 cm + DMP 75 + DWC 5
	in	DP 60	DMP 45 + DWC 5	DMP 45	DP 30 + DWC 5	DP 30	DP 30
105°	Outside	2 cm + DMP 75	1 cm + DMP 75	DMP 75 + DWC 5	4 cm + DMP 75 + DWC 5	2 cm + DMP 75	1 cm + DMP 75
	in	DP 60 + DWC 5	DP 60	DP 60	DP 60	DMP 45 + DWC 5	DMP 45
120°	Outside	4 cm + DMP 75 + DWC 5	2 cm + DMP 75	DMP 75	3 cm + DMP 75	DMP 75 + DWC 5	4 cm + DMP 75 + DWC 5
	in	DMP 75	DP 60 + DWC 5	DP 60	DP 60	DP 60	DP 60
135°	Outside	2 cm + DMP 45 + DWC 5	4 cm + DMP 45 + DWC 5	1 cm + DMP 45	3 cm + DMP 45	DMP 45	2 cm + DMP 45
	in	DMP 45	DMP 45	DP 30 + DWC 5	DP 30 + DWC 5	DP 30	DP 30
150°	Outside	4 cm + DMP 45	DMP 45 + DWC 5	2 cm + DMP 45 + DWC 5	3 cm + DMP 45 + DWC 5	DMP 45	1 cm + DMP 45
	in	DMP 45	DMP 45	DMP 45	DMP 45	DP 30 + DWC 5	DP 30 + DWC 5
165°	Outside	2 cm + DMP 45	3 cm + DMP 45	3 cm + DMP 45	4 cm + DMP 45	DMP 45 + DWC 5	DMP 45 + DWC 5
	in	DMP 45	DMP 45	DMP 45	DMP 45	DMP 45	DMP 45

Tab. B1.01

## DOMINO DUO adapters



The maximum permissible fresh concrete pressure is 50 kN/m<sup>2</sup>

### Components

- 67** DOMINO DUO adapter (131241)
- 68** DOMINO DRS alignment coupler (066080)
- 87.1** DOMINO DGE 150 articulated corner (124605)
- 87.2** DOMINO DGE 275 articulated corner (105708)
- 87.3** DOMINO DGE 300 articulated corner (066009)

The DOMINO DUO adapter (**67**) makes it possible to connect the DOMINO DGE articulated corner (**87**) to the DUO DP panels (**10**).

The DOMINO DUO adapter (**67**) has ties (**67.1**) that secure the frame profile (**10.9**) of the DUO DP panel (**10**) in the connector pocket and are mounted opposite the formlining (**10.7**). (Fig. B1.27 + Fig. B1.28)

The DOMINO DUO adapter (**67**) can be used in conjunction with the DOMINO DRS alignment coupler (**68**). (Fig. B1.29)

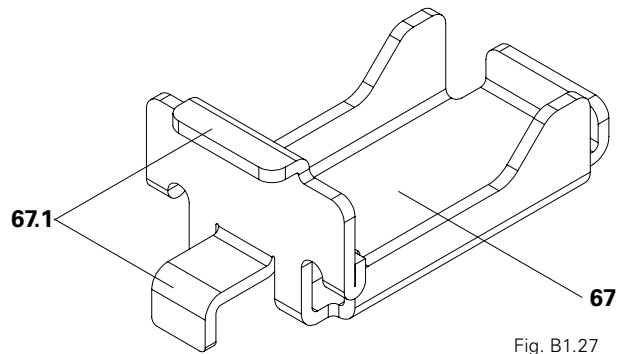

Fig. B1.27

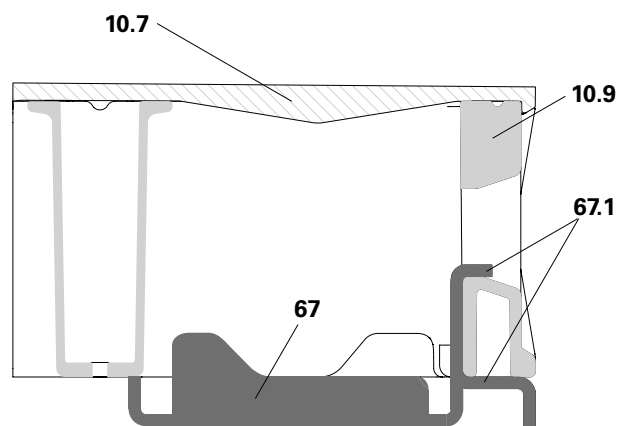

Fig. B1.28

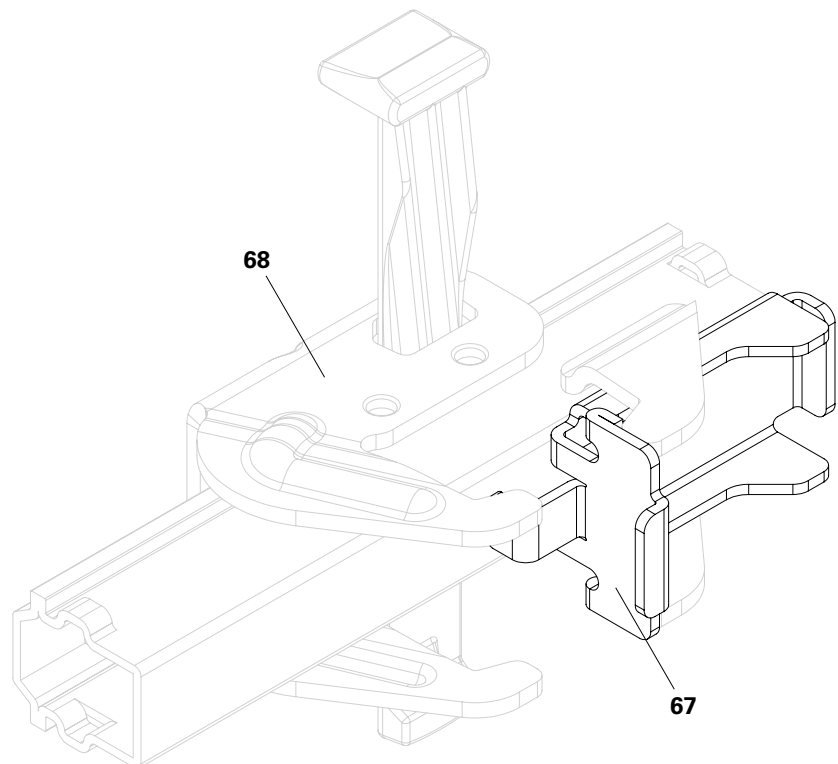

Fig. B1.29

## Layout of the DOMINO DRS locks (using DOMINO DUO adapters)

### Internal formwork:

On the internal formwork, two DOMINO DRS alignment couplers (**68**) are required for each DUO DP 135 panel (**10**). If the DWC wall thickness compensator  $\geq 7$  cm (**13**) is used, then the DUO 62 compensation waler must be used.

Four DUO couplers (**21**) must be installed for each DUO DP panel (**10**) along the vertical joint.

On the internal formwork, only the DW 15 cam nut can be used in the vicinity of the DOMINO DGE articulated corner (**87**). If the DUO couplers (**21**) get in each other's way, then they will need to be offset from one another on the left and right formwork side.

(Fig. B1.30)

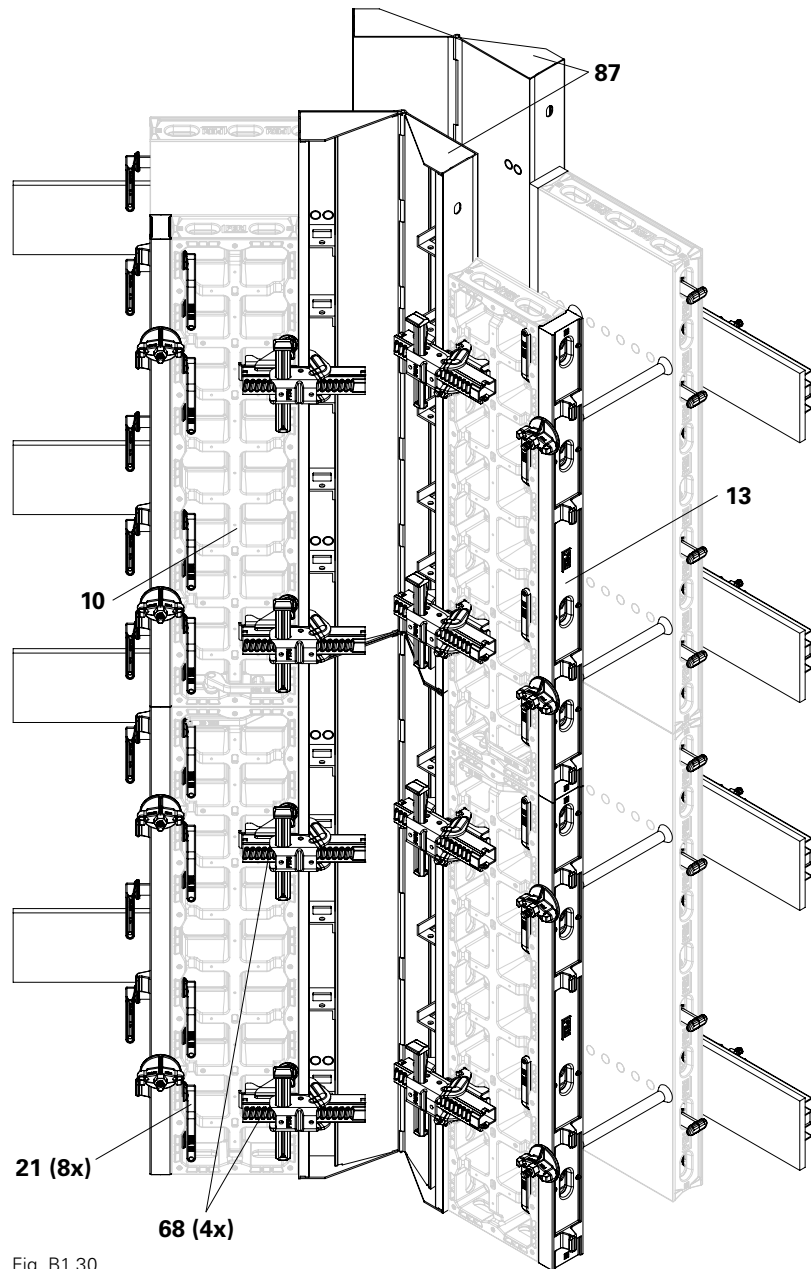

Fig. B1.30

## External formwork:

If there is a requirement for compensation, square timber (91) with a thickness of up to 5 cm can be mounted next to the DOMINO DGE articulated corner. This allows for the use of tie rods at right angles to the DUO formwork.

The following elements are always required for the external formwork:

- Two DOMINO DRS alignment couplers (68) per DUO DP panel (10),
- Two DAR compensation walers (66) per DUO DP panel (10).

If the parts get in each other's way (e.g. locks and walers), then the locks can be mounted on the next adjacent strut.

Four DUO couplers (21) must be installed for each DUO DP 135 panel along the vertical joint. DAR compensation walers (66) are installed to cover the joint between the DOMINO DGE articulated corner (87) and the DUO panels (10).

The 18 mm multi-layer plywood sheathing Finply (92) must be installed beneath the DAR compensation walers (66) in order to provide both the DOMINO DGE articulated corner and the DUO DP panel (10) with sufficient support.

(Fig. B1.31)

### Angle $\alpha \leq 120^\circ$ :

**The external formwork must be stiffened with a longer LWR 170 waler (80.2) (art. no.: 125473).**

### Angle $\alpha > 135^\circ$ :

**The external formwork must be stiffened with DAR 80 walers (66.1) (art. no.: 066084).**

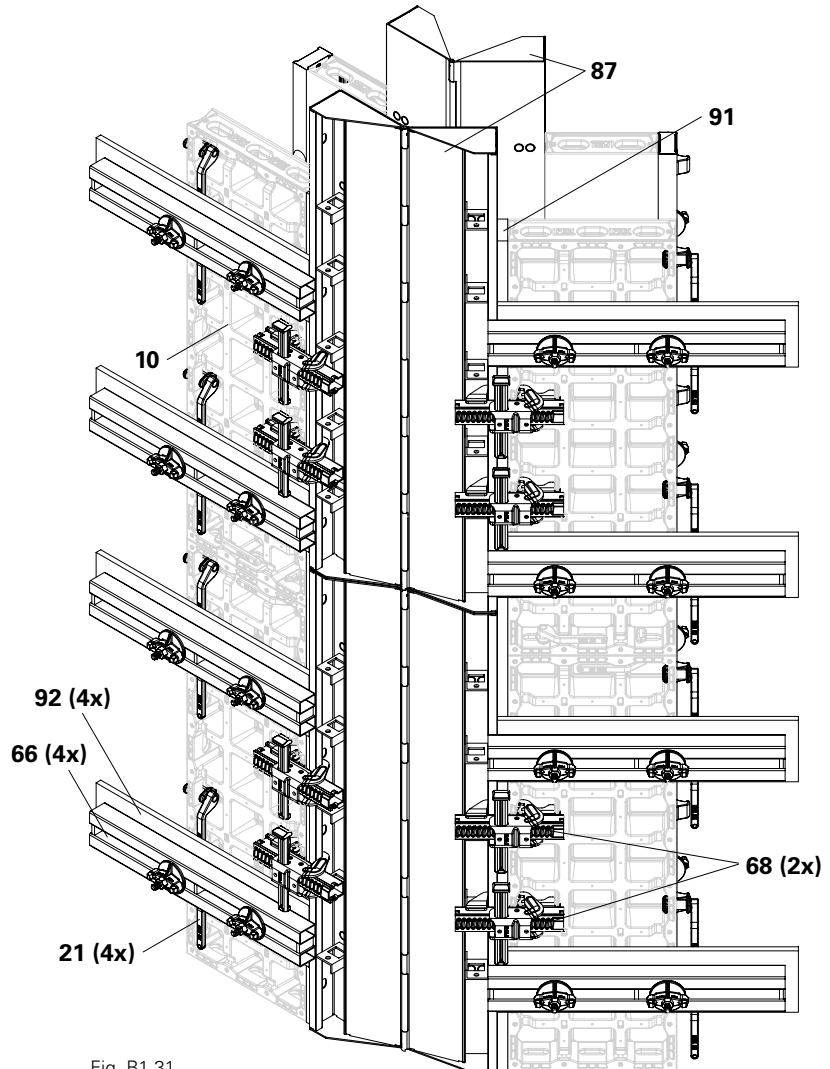

Fig. B1.31

## Layout of the DAR 80 compensation walers (66.1) or LWR 170 walers (80.2) on the external formwork

X = centimetre-based timber compensations (up to 5 cm can be realised)



- **Angle  $\alpha \leq 120^\circ$ :** The external formwork must be stiffened with a longer waler, e.g. LWR 170 waler (80.2), art. no.: 125473.
- **Angle  $\alpha > 135^\circ$ :** The external formwork must be stiffened with DAR 80 walers (66.1), art. no.: 066084.

A DAR 80 compensation waler (66.1), or an even longer one (e.g. LWR 170 compensation waler) (80.2), must be installed. This must support the DOMINO DGE articulated corner (87) at 25 mm and cover the joint (a) between the DUO DP 135 panels (10). (Fig. B1.32)

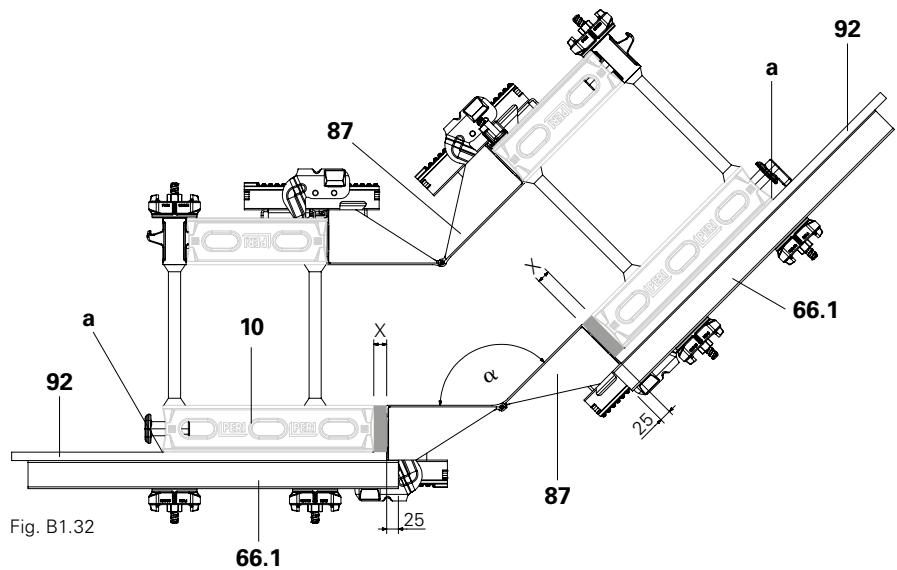

Fig. B1.32

The number of DUO couplers is dependent on the length of the walers used. The 18 mm multi-layer plywood sheathing Finply (92) must be installed beneath the LWR 80 (80.1) walers in order to provide both the DOMINO DGE articulated corner (87) and the DUO DP panels with the correct support. (Tab. B1.02)

### Components required

In combination with the DOMINO DGE articulated corner (87), it is possible to form angles between  $75^\circ$  and  $165^\circ$ .

The wall thickness in these cases can range from 15 cm to 40 cm.

(Tab. B1.02)

The DOMINO DRS alignment coupler (68) is installed from bottom to top, both for external and internal corners.

Angle $\alpha$	Formwork side	Wall thickness [cm]					
		15	20	25	30	35	40
75°	Outside	DMP 75 + DWC 5	2 cm + DMP 75	4 cm + DMP 75	DMP 75	2 cm + DMP 75	3 cm + DMP 75 + DWC 5
	in	DP 60	DMP 45 + DWC 5	DMP 45	DP 30 + DWC 5	DP 30	DP 30
105°	Outside	2 cm + DMP 75	1 cm + DMP 75	DMP 75 + DWC 5	4 cm + DMP 75 + DWC 5	2 cm + DMP 75	1 cm + DMP 75
	in	DP 60 + DWC 5	DP 60	DP 60	DP 60	DMP 45 + DWC 5	DMP 45
120°	Outside	4 cm + DMP 75 + DWC 5	2 cm + DMP 75	DMP 75	3 cm + DMP 75	DMP 75 + DWC 5	4 cm + DMP 75 + DWC 5
	in	DMP 75	DP 60 + DWC 5	DP 60	DP 60	DP 60	DP 60
135°	Outside	2 cm + DMP 45 + DWC 5	4 cm + DMP 45 + DWC 5	1 cm + DMP 45	3 cm + DMP 45	DMP 45	2 cm + DMP 45
	in	DMP 45	DMP 45	DP 30 + DWC 5	DP 30 + DWC 5	DP 30	DP 30
150°	Outside	4 cm + DMP 45	DMP 45 + DWC 5	2 cm + DMP 45 + DWC 5	3 cm + DMP 45 + DWC 5	DMP 45	1 cm + DMP 45
	in	DMP 45	DMP 45	DMP 45	DMP 45	DP 30 + DWC 5	DP 30 + DWC 5
165°	Outside	2 cm + DMP 45	3 cm + DMP 45	3 cm + DMP 45	4 cm + DMP 45	DMP 45 + DWC 5	DMP 45 + DWC 5
	in	DMP 45	DMP 45	DMP 45	DMP 45	DMP 45	DMP 45

Tab. B1.02

## DUO SB hook straps

DUO SB hook straps (**81**) are used to connect PERI brace frames (SB-A0, A, B, C, SB-1, SB-2, SB-L) and DUO DP panels (**10**) in combination with the DUO 62 compensation waler (**25**). (Fig. B1.33 + Fig. B1.34a)

### Installation

These instructions apply to all SB brace frames but only in combination with the Instructions for Assembly and Use for the SB brace frame.

The brace frames must be fixed to vertical frames of the installed DP panels. The maximum permissible width of influence is 0.9 m.

(Fig. B1.34)

1. Install compensation waler DUO 62 (**25**) with DUO tube holder (**24**).
2. Fit at least two DUO 62 compensation walers (**25**) onto each vertical joint on panel DP 135 (**10**). Choose the correct position depending on the SB brace frame so that the DUO SB hook strap (**81**) is correctly positioned. (Fig. B1.35)
3. Attach the DUO SB hook strap (**81**) to the DUO 62 compensation waler (**25**). Ensure that the DUO SB hook strap (**81**) is correctly positioned. (Fig. B1.34a + Fig. B1.35)
4. Secure the DUO SB hook strap (**81**) with nuts.

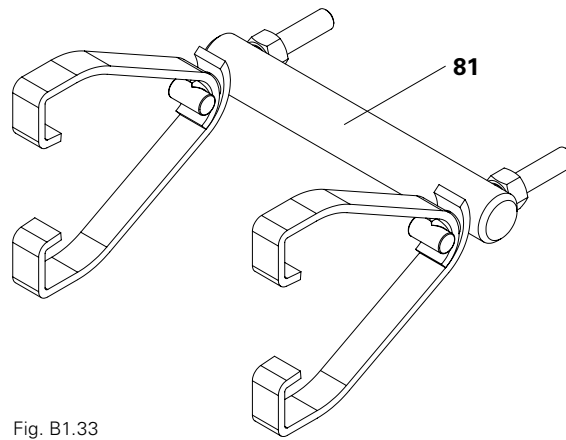

Fig. B1.33

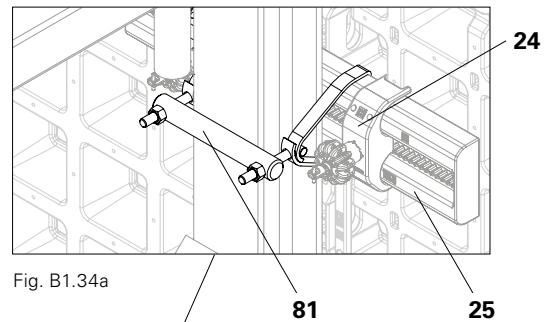

Fig. B1.34a

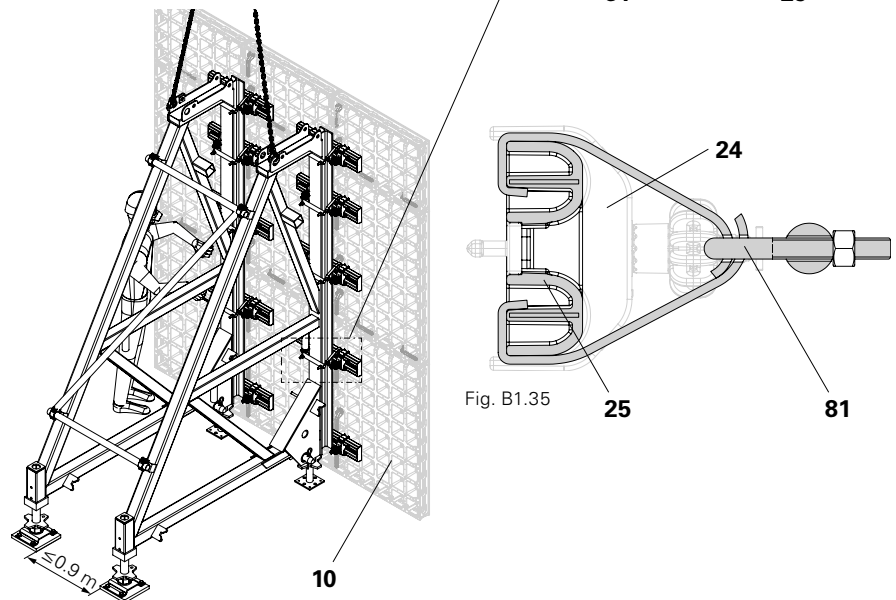

Fig. B1.34

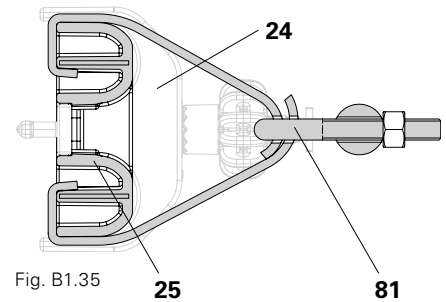

Fig. B1.35

## Transport by crane



### Warning

Heavy components may fall down due to overloading!

This can lead to death or serious, irreversible injuries.

- ⇒ Always transport the movable units on the intended load bearing points!
- ⇒ Do not transport the movable units using DUO crane lugs!
- ⇒ Do not attach lifting gear directly to DUO DP panels (**10**)!
- ⇒ Observe the Instructions for Assembly and Use for the SB brace frame!
- ⇒ Observe the permitted load-bearing capacity!
- ⇒ Do not use a crane to release the movable unit from concrete!
- ⇒ The fastenings/wedges must be checked before all transport movements. If necessary, secure the wedges with bolts and cotter pins or screws.

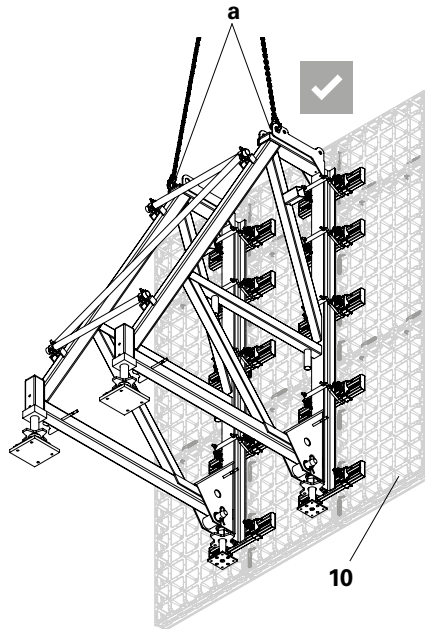

Fig. B1.36

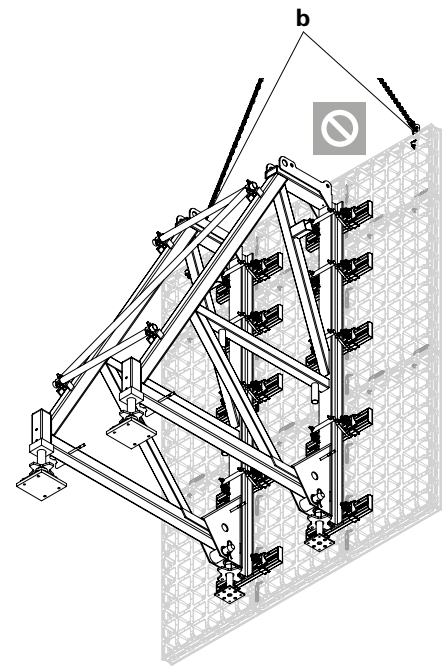

Fig. B1.37

The attachment points (**a**) may be used. (Fig. B1.36)

The attachment points (**b**) must not be used! (Fig. B1.37)

## Connection to SB systems

Max. compensation width = 0.9 m

SB-1 (Fig. B1.38)

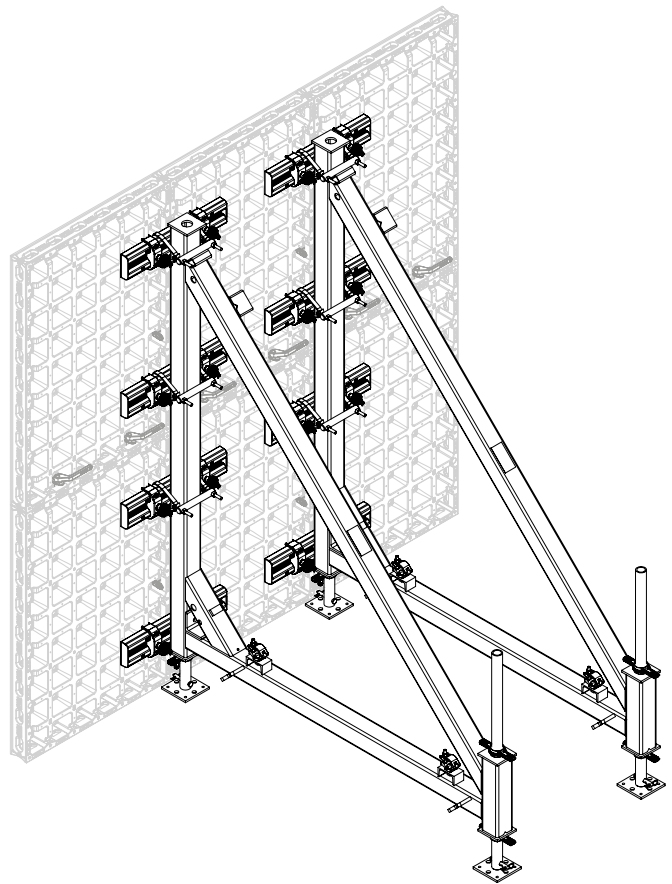

Fig. B1.38

SB-2 (Fig. B1.39)

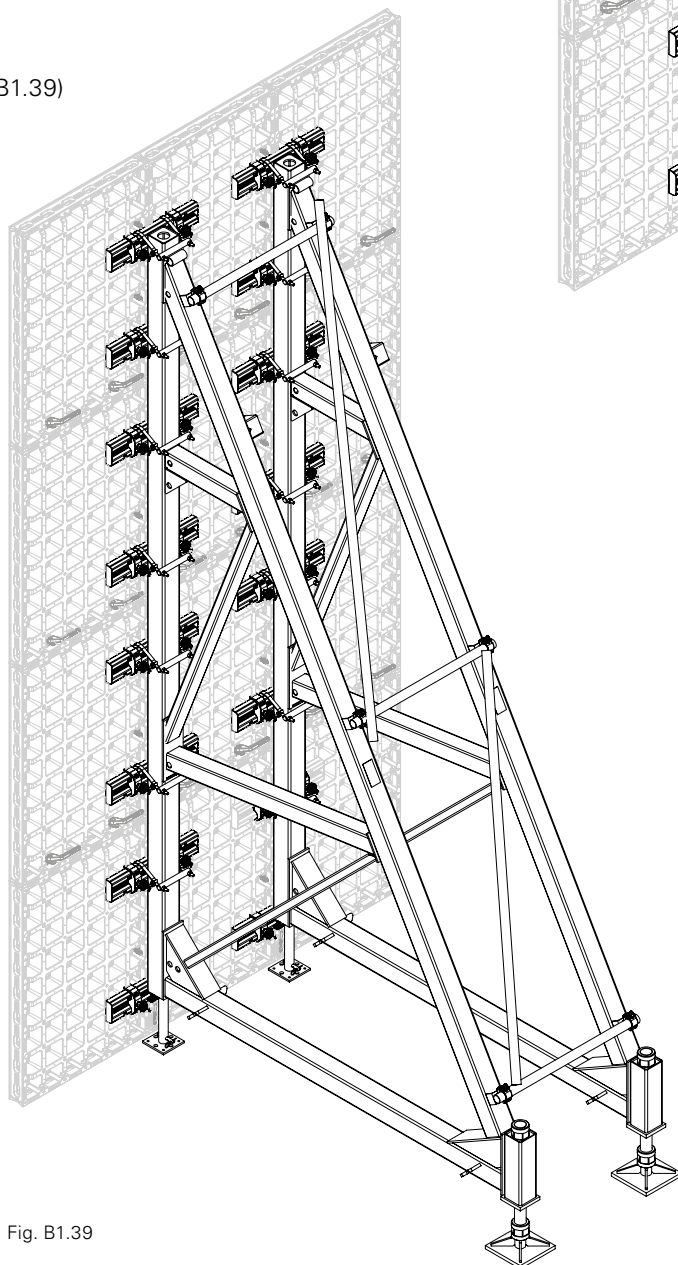

Fig. B1.39

SB-A0, A, B, C (Fig. B1.41)

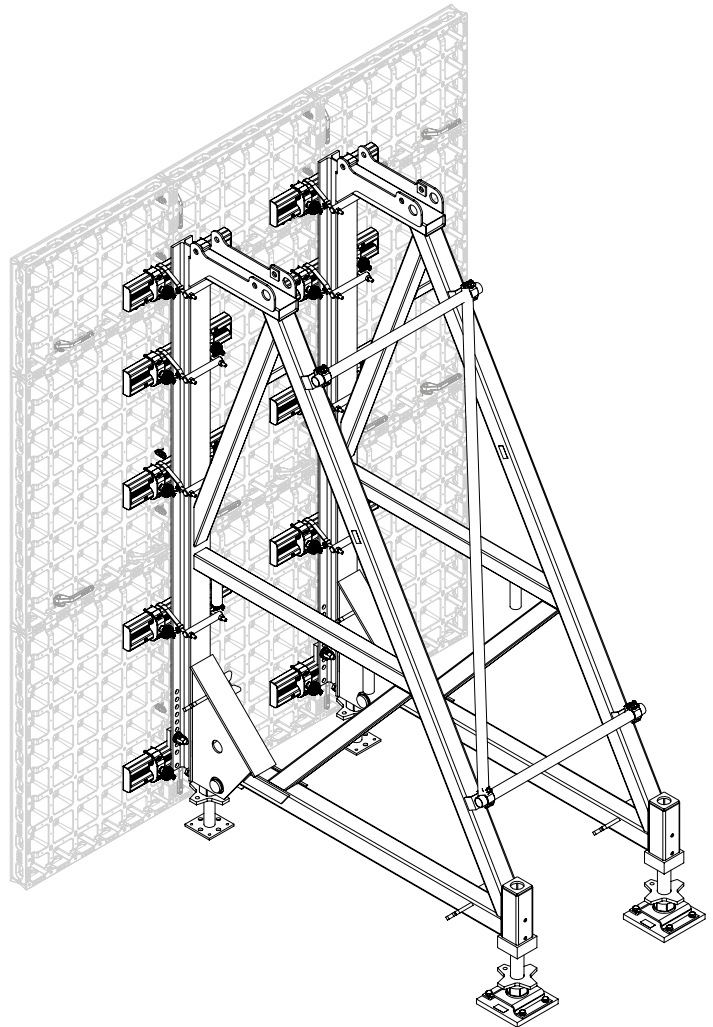

Fig. B1.40

SB-L (Fig. B1.41)

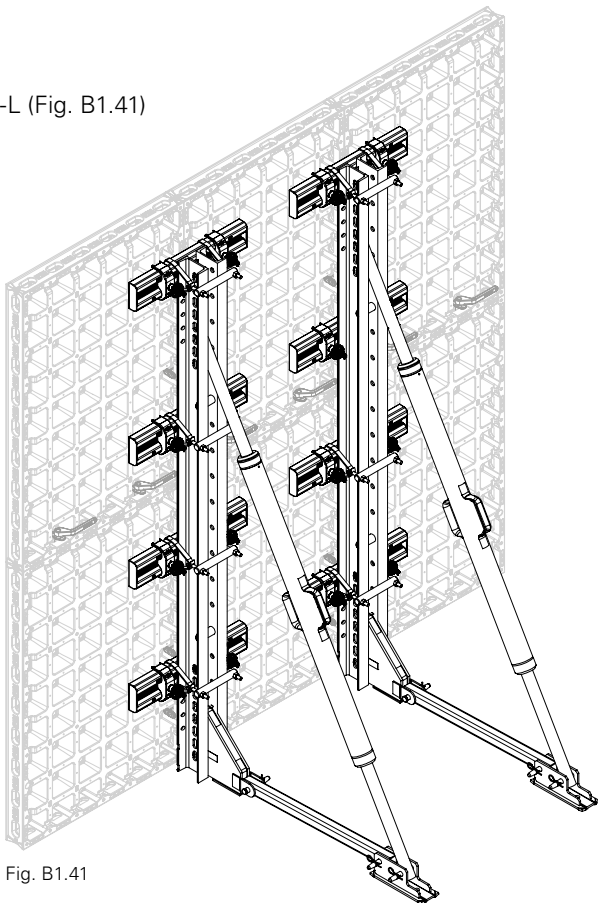

Fig. B1.41

## DW 15 tie system

Perm. load of tie rod DW 15: 90 kN.

### Required components:

<b>50</b>	Tie rod DW 15	1x
<b>41</b>	Spacer tube DR 22	1x
<b>42</b>	Cone DR 22	2x
<b>54</b>	Wingnut counterplate DW 15	2x

(Fig. B2.01)

### Application

- Only use the required number of ties; for tie positions: see images in all sections.
- Do not exceed permissible tie load of 90 kN.
- Seal tie holes that are not required.

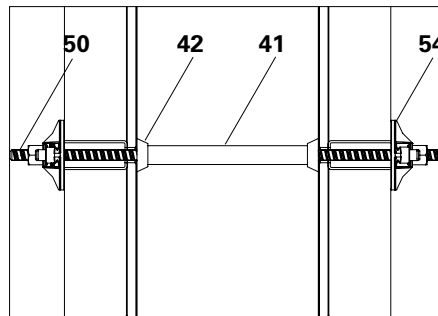

Fig. B2.01



Wingnut counterplate DW 15 must cover the frames of the adjacent DP panels by at least 12 mm. If not, mount compensation waler DUO 62!

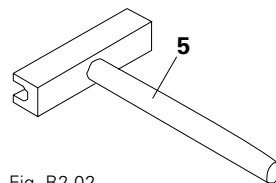

Fig. B2.02

### Accessories

Tie rod wrench (**5**) for one-man tie point operations from one side of the formwork. (Fig. B2.02)

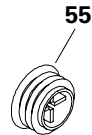

Fig. B2.03

Plugs (**55**) for closing unused tie holes. (Fig. B2.03)

## DUO brace connectors

Push-pull props and kicker braces are fastened to the connection point of the DP panel by means of the DUO brace connector (27).

### Installation

1. Hook the DUO brace connector (27) into a connection point (10.3) on the DP panel with a cross tie bolt (27.1).
2. Turn the cross tie bolt (27.1) through 90°.
  - The securing pin (27.3) is in a vertical position.
3. Tighten the DUO brace connector with the DW 15 grip (27.2).

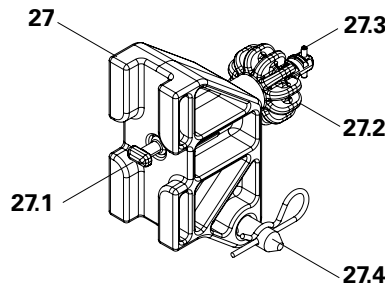

Fig. B3.01

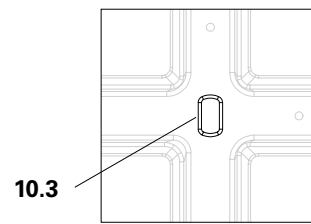

Fig. B3.02

## Push-pull props and kicker braces

Push-pull props and kicker braces are mounted in order to align the formwork as well as provide stability along with resistance against wind loads. The choice of the push-pull prop and kicker brace is determined by the height of the formwork. (Fig. B3.03)  
The maximum width of influence is 2.70 m. Observe table for PERI push-pull props and kicker braces.

### Required components:

<b>27</b>	Brace connector	2x
<b>38</b>	Push-pull prop	1x
<b>39</b>	Kicker brace	1x
<b>30</b>	Base plate-3 for RS 210 – 1400	1x
<b>30.1</b>	Anchor bolt	1x

### Installation

1. Mount push-pull prop (38) and kicker brace (39) on the DUO brace connector (27) and secure with bolt and cotter pin (27.4). (Fig. B3.03a + Fig. B3.03b)
2. Mount base plate-3 for RS 210 – 1400 (30) on the push-pull prop and kicker brace. (Fig. B3.04)
3. Fasten base plate-3 for RS 210 – 1400 (30) on a load-bearing surface, e.g. with PERI anchor bolt 14 / 20 x 130 (30.1), art. no. 124777. Take the Technical Data Sheet into consideration! (Fig. B3.04)
4. Fix push-pull props to the base plate with bolts, and secure bolts with cotter pins (27.4). (Fig. B3.04)
5. Check stability and alignment in all directions.

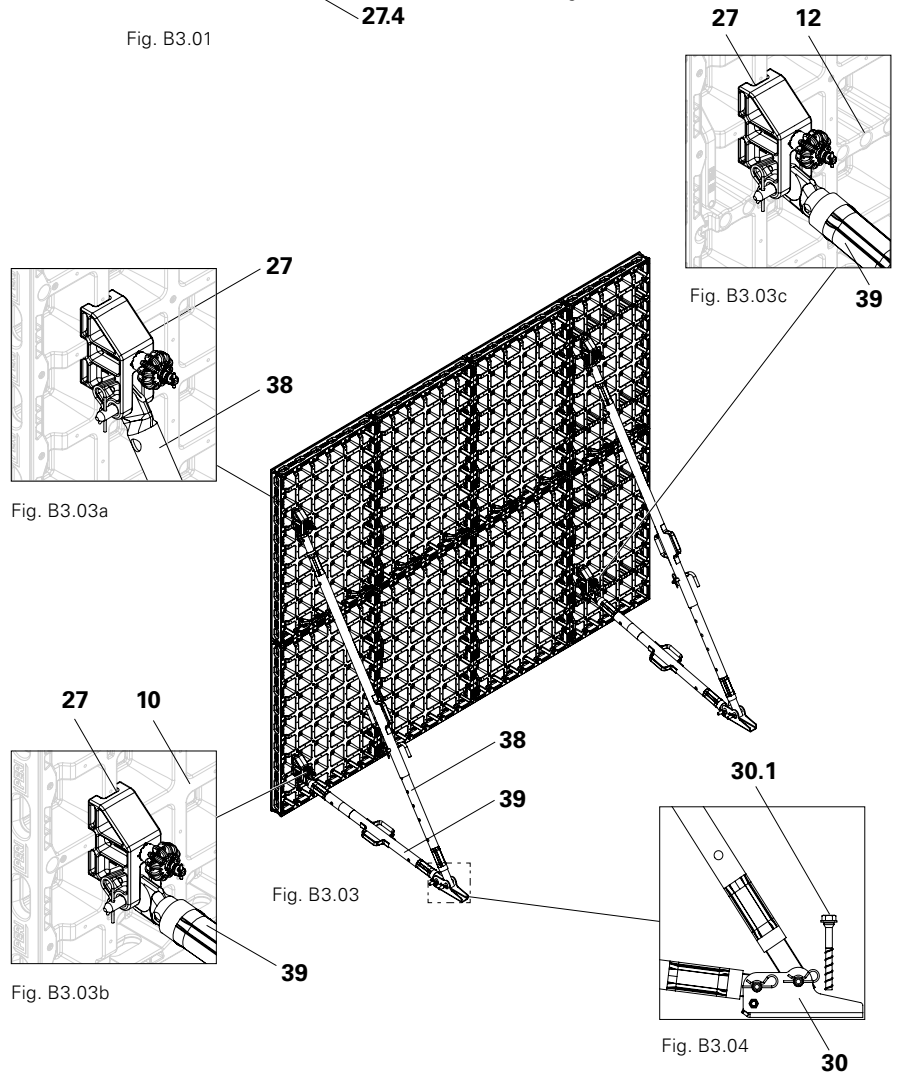

**Table of PERI push-pull props and kicker braces 1 of 2**

	Formwork height h [m]														
		0.90	1.35	1.95	2.10	2.25	2.55	2.70	2.85	3.00	3.15	3.30	3.45	3.60	3.90
<b>Permissible width of influence [m]</b>	<b>W<sub>ref</sub></b>	30.3	13.2	6.20	5.20	4.40	3.50	3.00	2.70	2.70	2.60	2.40	2.20	2.20	2.30
<b>x =</b> Distance from base plate to rear edge of formwork [m]	<b>x</b>	1.10	1.10	1.10	1.10	1.10	1.10	1.10	1.10	1.30	1.30	1.30	1.30	1.4	1.7
<b>y =</b> *Top connection point measured from top of formwork [m]	<b>y</b>	0.15	0.15	0.30	0.45	0.60	0.75	0.90	1.05	1.20	1.05	1.05	1.20	1.20	0.90
<b>c =</b> *Bottom tie point measured from bottom of formwork [m]	<b>c</b>	0.30	0.30	0.30	0.30	0.30	0.30	0.30	0.30	0.30	0.30	0.30	0.30	0.30	0.30
Actual push-pull prop load [kN]	<b>F<sub>PP</sub></b>	7.00	7.00	7.00	7.00	7.00	7.00	7.00	7.00	7.00	7.00	7.00	7.00	7.00	7.00
Actual kicker brace load [kN]	<b>F<sub>KB</sub></b>	12.0	6.90	4.00	3.20	2.60	2.00	1.60	1.30	1.10	1.60	1.60	1.30	1.40	2.20
<b>Base plate</b> Resulting force [kN]		18.7	13.3	10.4	9.70	9.10	8.60	8.30	8.00	7.80	8.20	8.20	8.00	8.00	8.60
Resulting angle of attack [°]		22.2	31.5	41.6	43.7	45.6	49.2	50.8	52.3	49.1	50.5	51.8	53.0	52.1	48.9

Tab. B3.01

**Table of PERI push-pull props and kicker braces 2 of 2**

	Formwork height h [m]									
		4.05	4.20	4.35	4.50	4.65	4.80	4.95	5.25	5.40
<b>Permissible width of influence [m]</b>	<b>W<sub>ref</sub></b>	2.10	1.90	1.80	1.70	1.60	1.50	1.40	1.80	1.70
<b>x =</b> Distance from base plate to rear edge of formwork [m]	<b>x</b>	1.70	1.70	1.70	1.70	1.70	1.80	1.80	2.50	2.50
<b>y =</b> *Top connection point measured from top of formwork [m]	<b>y</b>	1.05	1.20	1.50	1.50	1.65	1.65	1.80	0.90	1.05
<b>c =</b> *Bottom tie point measured from bottom of formwork [m]	<b>c</b>	0.30	0.30	0.30	0.30	0.30	0.30	0.30	0.30	0.30
Actual push-pull prop load [kN]	<b>F<sub>PP</sub></b>	7.00	7.00	7.00	7.00	7.00	7.00	7.00	7.00	7.00
Actual kicker brace load [kN]	<b>F<sub>KB</sub></b>	2.00	1.80	1.30	1.30	1.20	1.30	1.10	2.60	2.40
<b>Base plate</b> Resulting force [kN]		8.40	8.20	7.90	7.90	7.80	7.90	7.70	8.80	8.70
Resulting angle of attack [°]		50.0	51.0	52.0	52.9	53.8	53.1	54.0	46.4	47.2

Tab. B3.02

**Note:**

Protection against lifting is provided if  $1.5 \times V_{Wind} - 0.9 \times G \times h > 0$ .

\*If necessary, the distances must be adapted to the existing system measurement of the formwork system.

**Load assumptions:**

- Formwork in vertical position on ground
- Wind loads according to DIN 1055-4:2005-03  $w = q(z) \cdot c_p \cdot \kappa$  [kN/m<sup>2</sup>]
- Inland, Wind Load Zone 2
- Peak velocity pressure  $q(z) = 0.59$
- Assumed pressure coefficient  $c_p = 1.8$
- Exposure time factor  $\kappa = 0.6$
- Inclination of the push-pull props to the horizontal 60°
- Values are characteristic values
- In the case of deviating boundary conditions, the PERI Design Tables should be taken into account and the permissible width of influence (WI) adjusted accordingly:  $WI = WI_{ref} \times w_{ref}/w$

Uplift force to be anchored

$F_{A,d} = 1.5 \times V_{Wind} - G \times h$  with  $G =$  surface area weight of the formwork including platforms.

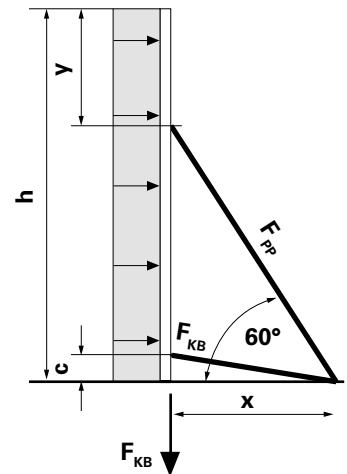

**⚠ Danger**

Risk of injury!  
Risk of falling!

- ⇒ Decking components and ladder cages must be mounted securely in position at all times.
- ⇒ Planking must be closed over the entire surface.
- ⇒ In order to secure the scaffold bracket against levering out, the first plank must be directly adjacent to the DP panel.
- ⇒ Assembly must be carried out from a safe working position!

### DUO scaffold brackets

**Permissible load 150 kg/m<sup>2</sup>**  
**Maximum width of influence 1.80 m**

A concreting platform is erected on the DUO formwork by means of DUO 70 scaffold brackets. (Fig. B4.01 + Fig. B4.02)

**Required components:**

<b>70</b> DUO 70 scaffold bracket	1x
<b>71</b> PP post	1x



Assembly takes place on vertically-positioned formwork. The scaffold bracket can be installed in any connector pocket of the DP panel.

**Installation**

1. Insert the PP post (71) into the DUO 70 scaffold bracket (70). (Fig. B4.02) → The PP post (71) engages with a clearly audible click.
2. Insert the upper flange (70.1) of the DUO 70 scaffold bracket (70) into the connector pocket (10.2) of the DUO DP panel (10). (Fig. B4.02a)
3. Turn the DUO 70 scaffold bracket (70) downwards until the lower flange (70.2) engages in the frame of the DUO DP panel (10). (Fig. B4.02a + Fig. B4.02b)

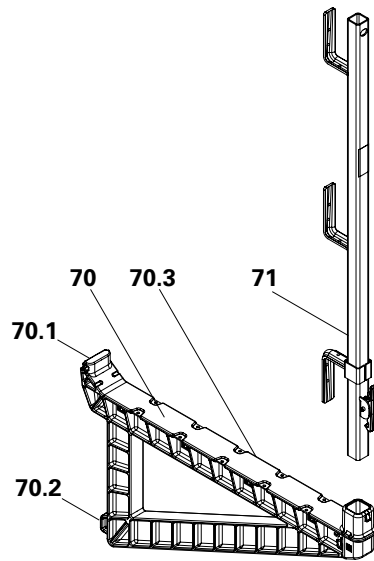

Fig. B4.02

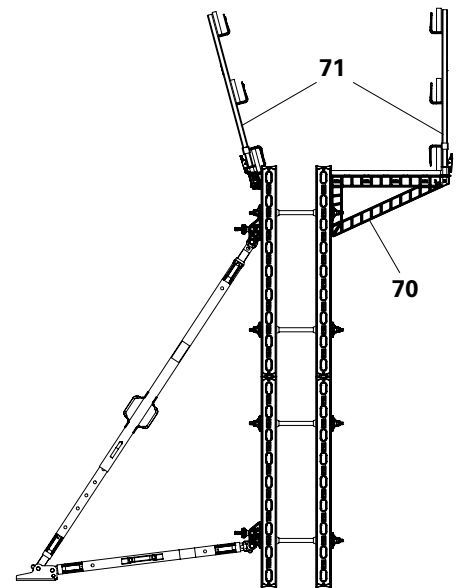

Fig. B4.01

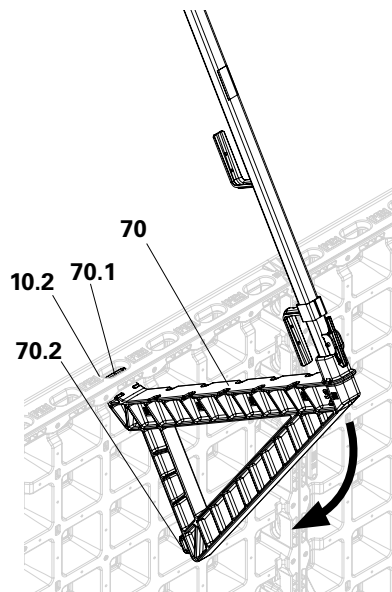

Fig. B4.02a

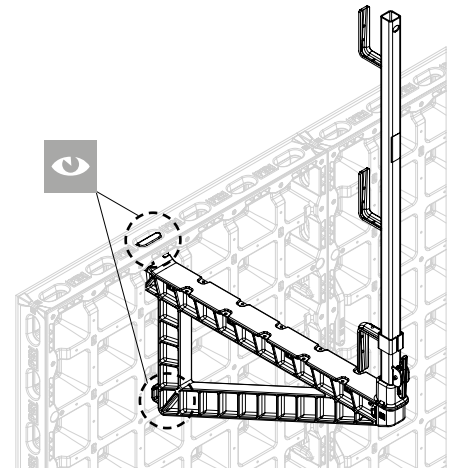

Fig. B4.02b



Visual check of the suspension equipment. (Fig. B4.02b)

4. Lay out 5 cm thick decking from underneath across the entire width of the bracket. The first plank must rest against the DP panel.  
(Fig. B4.03a)
5. Screw the decking from underneath through the screw holes (70.3) provided in the scaffold bracket using 5 x 40 Torx screws.
6. Install ladder cages and secure with nails.
7. Attach side protection, e.g. end guardrail frame 55 (78).  
(Fig. B4.03)

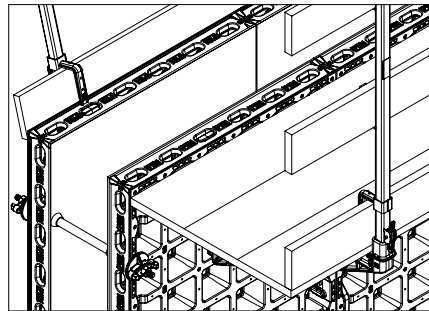

Fig. B4.03a

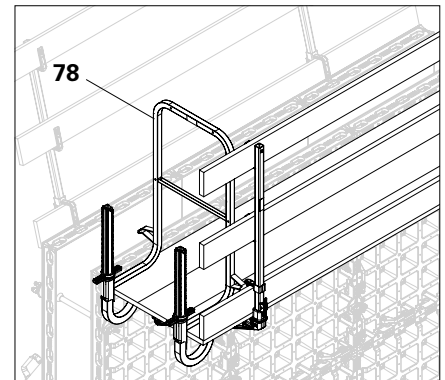

Fig. B4.03

## DUO front post holders

### Required components:

73 DUO front post holder	1x
71 PP post	1x



**Permissible load: as detailed in EN 12811-1**  
**Maximum width of influence: 1.80 m**

The DUO front post holder (73) is mounted on the DP wall formwork panel for the purpose of installing guardrails. Do not mount it on the slab formwork panel. A significant feature of this is that a range of PERI guardrail posts can be used (e.g. PP posts (71) and HSGP-2 guardrail posts (79)).  
 (Fig. B4.04 – Fig. B4.05b)

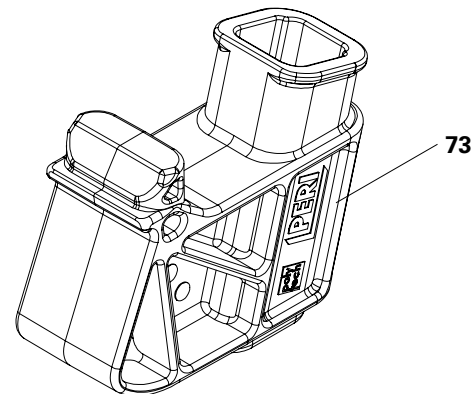

Fig. B4.04

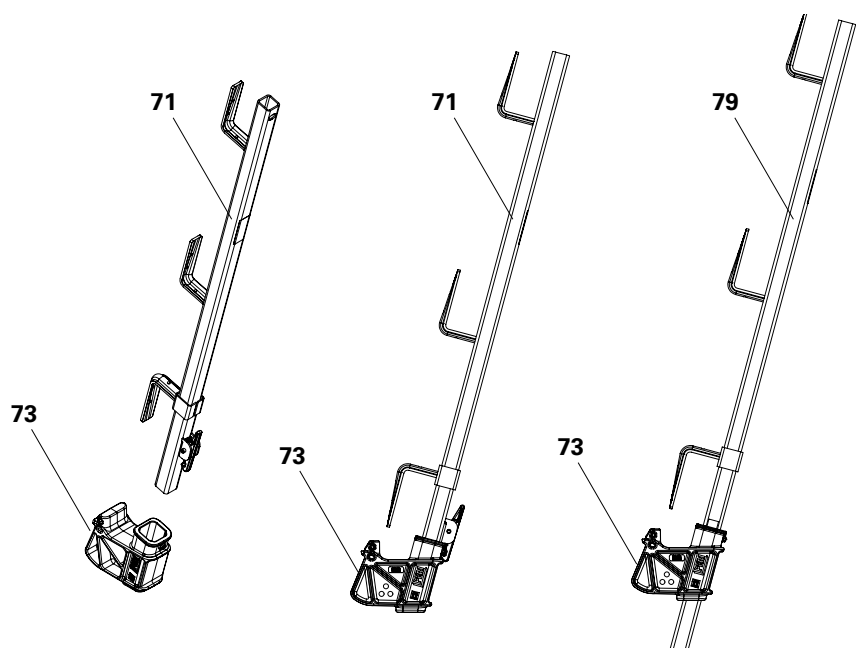

Fig. B4.05

Fig. B4.05a

Fig. B4.05b

## Assembly as opposing guardrails with guardrail boards

1. Position the bracket (73.1) of the DUO front post holder (73) at the grip hole of the DP panel (10.2). (Fig. B4.06)
2. Turn the DUO front post holder (73) into the grip hole until the bracket (73.1) engages and the lower ring of the DUO front post holder (73) is resting on the frame of the panel (10). (Fig. B4.07)
3. Insert the PP post (71) or the HSGP-2 into the DUO front post holder (73).

! The PP post (71) must engage with an audible click!

4. Place the toe boards (96) between the DP panel (21) and the DUO front post holder (73). Make sure that they are positioned correctly. The toe boards (96) must be pushed down as far as possible. The toe board (96) must fill out the seat of the DUO front post holder (73) entirely. This is the only way that the second toe board (96) can be fitted. Secure the guardrail with nails. (Fig. B4.08 + Fig. B4.09)

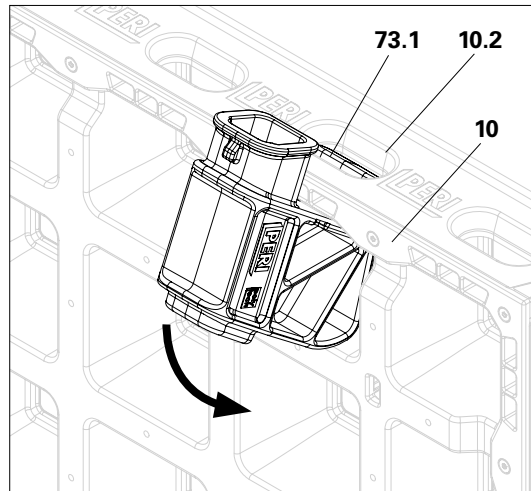

Fig. B4.06

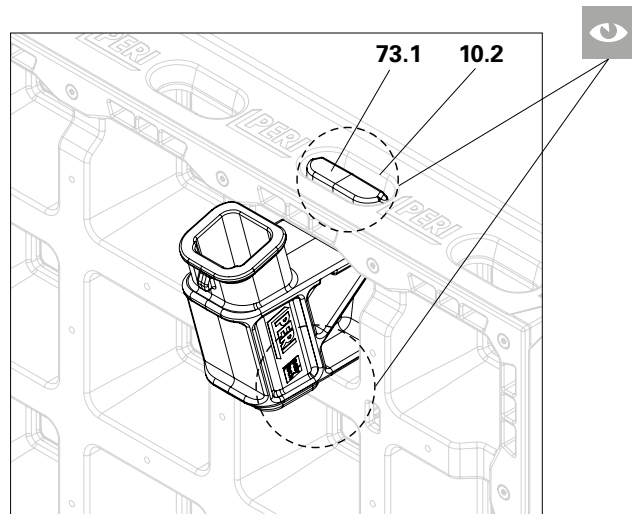

Fig. B4.07

## Assembly as opposing guardrails with PMB side mesh barrier

The PMB side mesh barrier (82) may only be used in combination with HSGP-2 guardrail posts (79) and toe boards (96).

The toe board (96) must fill out the seat of the DUO front post holder (73) entirely. This is the only way that the second toe board (96) can be fitted (as shown in Fig. B4.09).



The Prokit PMB side mesh barrier (82) can only be used in combination with HSGP-2 guardrail posts (79) and toe boards (96). (Fig. B4.10).



The securing hook on the PP post (71) must be hooked in after it is inserted into the flange on the DUO front post holder (73)!

The toe board (96) must be pushed downwards until it fills out the seat of the DUO front post holder (73) entirely.

### Striking

Do not place the formwork panels on the scaffold bracket or brace connector/opposing guardrail.

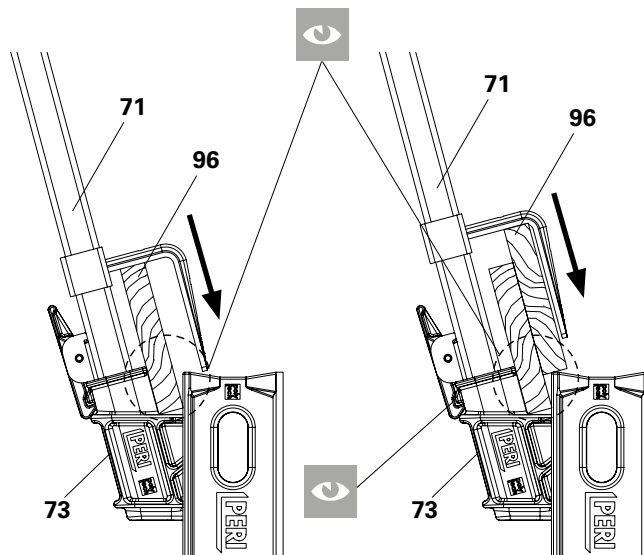

Fig. B4.08

Fig. B4.09

Fig. B4.10

## Assembly at internal corners

### Required components:

<b>70</b>	DUO 70 scaffold bracket	3x
<b>71</b>	PP post	2x

### Installation

1. Insert the first DUO 70 scaffold bracket (**70**) without PP post (**71**) into the first DP panel (**10**) next to the DP 135 x 15 panel (**11.1**). Use the connector pocket (**10.2**) closest to the corner.
2. Mount the second DUO 70 scaffold bracket (**70**) with PP post (**71**) cross-wise in front of the first scaffold bracket. Use the nearest connector pocket (**10.2**). The DUO 70 scaffold brackets (**70**) must not come into contact with each other.
3. Mount the third DUO 70 scaffold bracket (**70**) with PP post (**71**) on the opposite side of the DP panel, as close as possible to the second DUO 70 scaffold bracket (**70**). The DUO 70 scaffold brackets (**70**) must not come into contact with each other. (Fig. B4.11)
4. Install planking across the whole area by screwing it in from below, ensuring there are no gaps; see section B4 DUO scaffold bracket. (Fig. B4.03a)

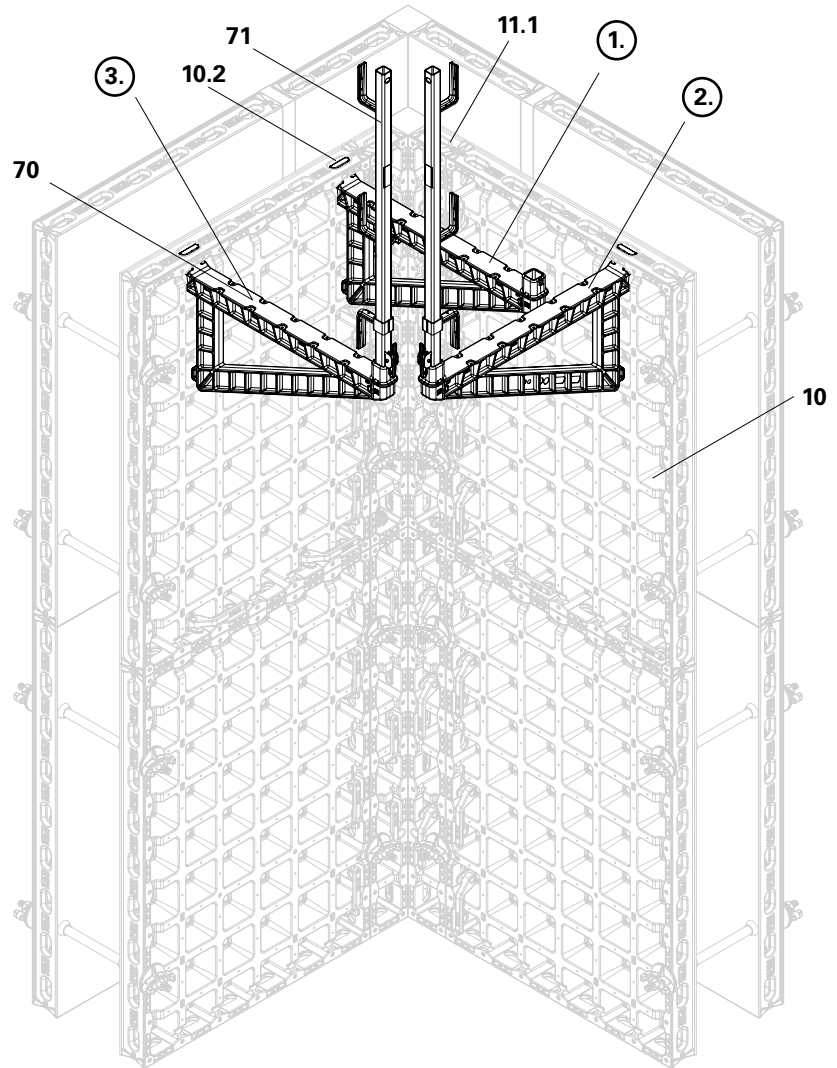

Fig. B4.11

## Assembly in case of height extensions

### Using DP 60 panels

The DUO 70 scaffold bracket (70) as well as the DUO front post holder (73) can be mounted on the DP 60 panels (18). (Fig. B4.12)

Assembly takes place in the same way as for DP 135 panels (10).

### Using DFP filler panels

Do **not** mount the DUO 70 scaffold bracket (70) and the DUO front post holder (73) on the DFP filler panel (17). (Fig. B4.13a)

If DFP filler panels (17) have been set up as height extensions, mount the DUO 70 scaffold bracket (70) and DUO front post holder (73) on the uppermost DP 135 (10) or DP 60 (18) panel. (Fig. B4.13)

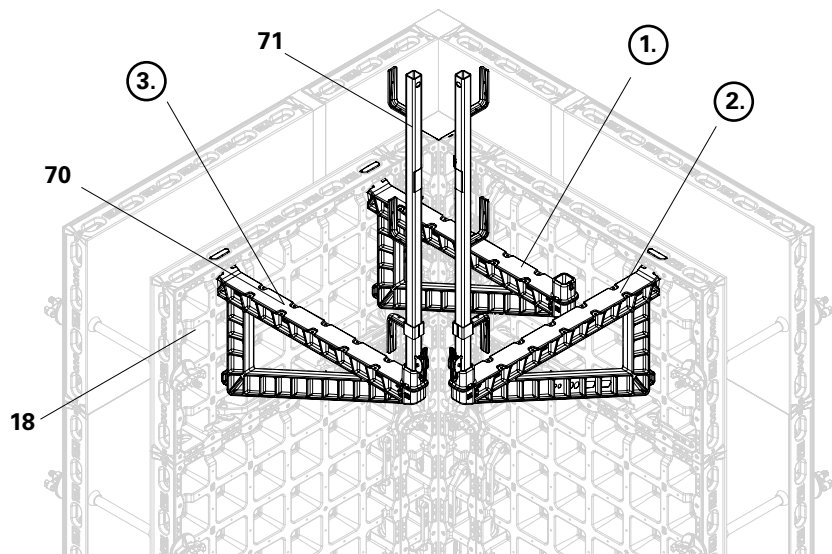

Fig. B4.12

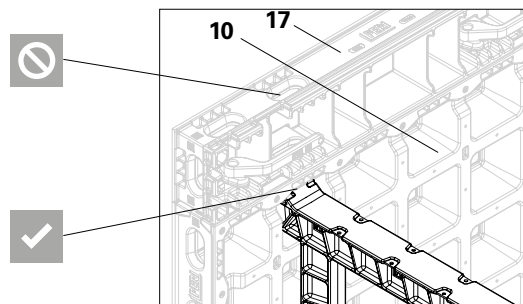

Fig. B4.12a

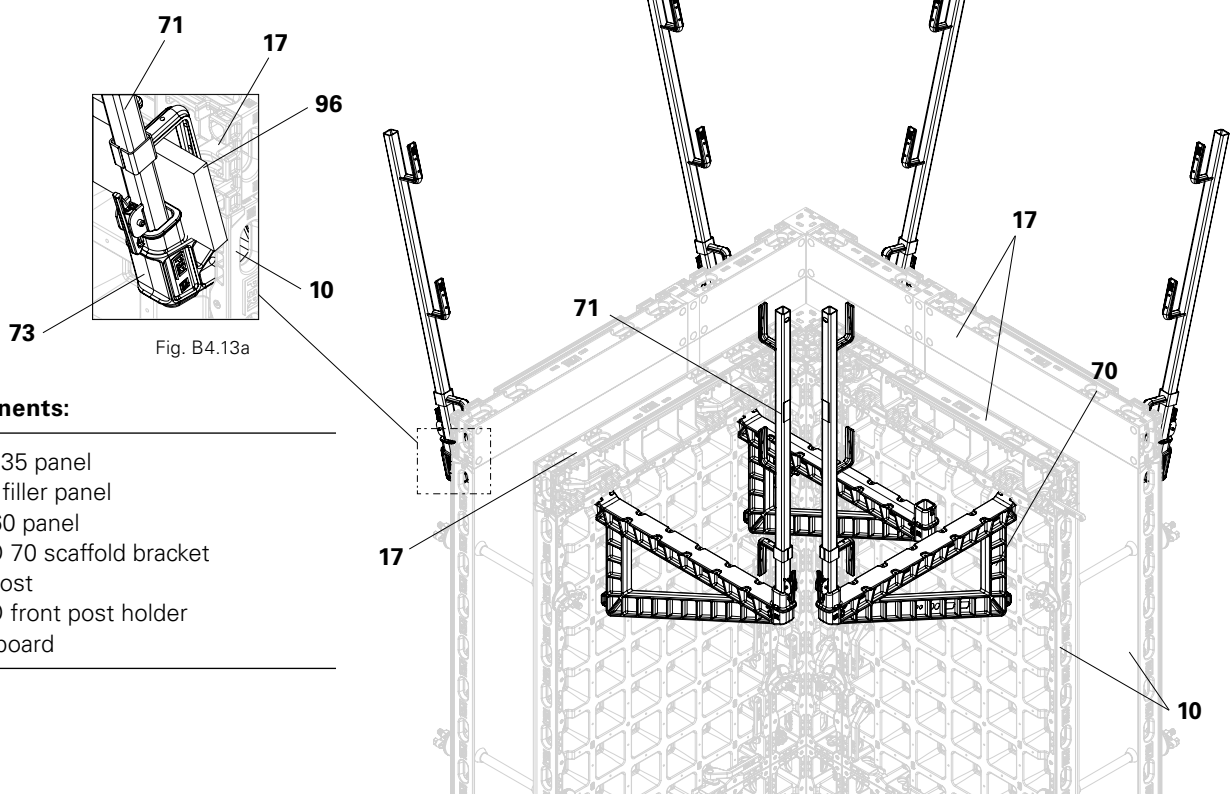

Fig. B4.13

### Components:

- 10 DP 135 panel
- 17 DFP filler panel
- 18 DP 60 panel
- 70 DUO 70 scaffold bracket
- 71 PP post
- 73 DUO front post holder
- 96 Toe board

## DC corner posts

Internal or external corners are realised with the DC 135 x 10 corner post (**20**).

### Required components for internal corners

<b>20</b>	DC 135 x 10 corner post	1x
<b>21</b>	DUO coupler	6x
<b>11.1</b>	DP 135 x 15 panel	2x

(Fig. B5.01a)

### Required components for external corners

<b>20</b>	DC 135 x 10 corner post	1x
<b>21</b>	DUO coupler	8x
<b>11.3</b>	DP 135 x 60 panel or	
<b>12.1</b>	DMP 135 x 45 multi panel	2x

(Fig. B5.01b)

### Installation

In order to connect the DC 135 x 10 corner post (**20**), the DUO coupler (**21**) of one DP panel must be pushed upwards and the DUO coupler of the other DP panel downwards.

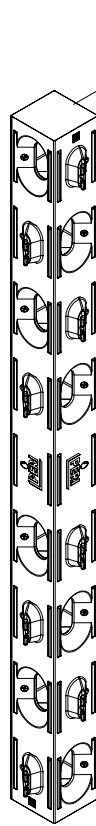

Fig. B5.01

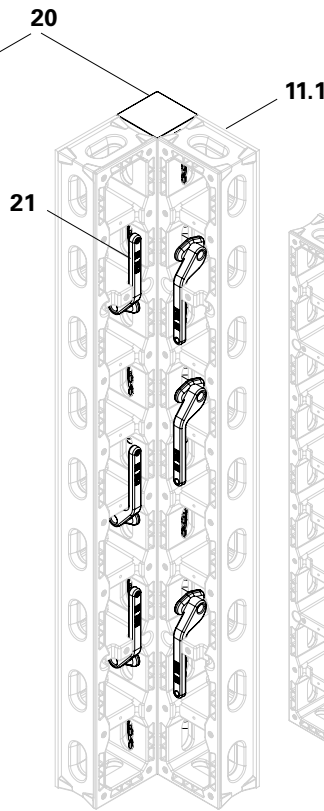

Fig. B5.01a

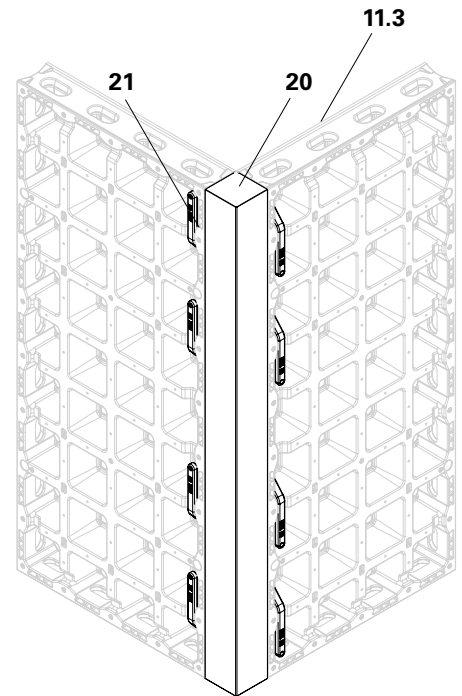

Fig. B5.01b

## Corner connections for extensions with the DP 60 panel

### Required components for internal corners

<b>20.1</b>	DC 60 x 10 corner post	1x
<b>21</b>	DUO coupler	2x
<b>18.1</b>	DP 60 x 15 panel	2x

(Fig. B5.02a)

### Required components for external corners

<b>20.1</b>	DC 60 x 10 corner post	1x
<b>21</b>	DUO coupler	4x
<b>18.3</b>	DP 60 x 60 panel or	
<b>19.1</b>	DMP 60 x 45 multi panel	2x

(Fig. B5.02b)

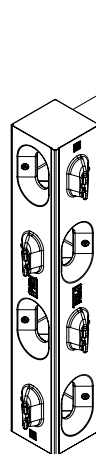

Fig. B5.02

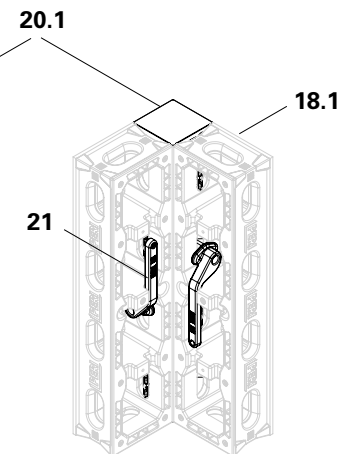

Fig. B5.02a

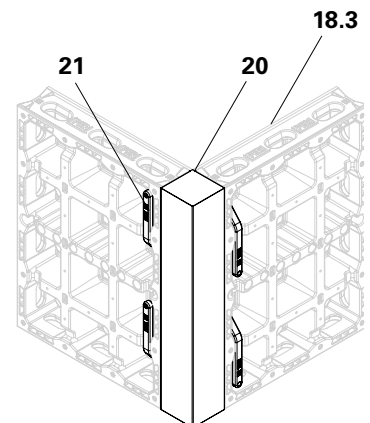

Fig. B5.02b

## Installation

1. Connect the DC corner post (**20**) and the DP 60 x 15 panel (**18.1**) using the DUO coupler (**21**).
2. Connect the DP 60 x 15 panels (**18.1**) with the DUO coupling tie (**22.1**) and the DW 15 grip (**22.2**).  
(Fig. B5.03)

## Relocation

For relocation tasks involving the crane, mount 2 DUO crane eyes (**28**).  
(Fig. B5.04)

Assembly and relocation of internal corners with the DC 60 corner post (**20**) and DC 60 x 15 panel (**18.1**) takes place in the same way.

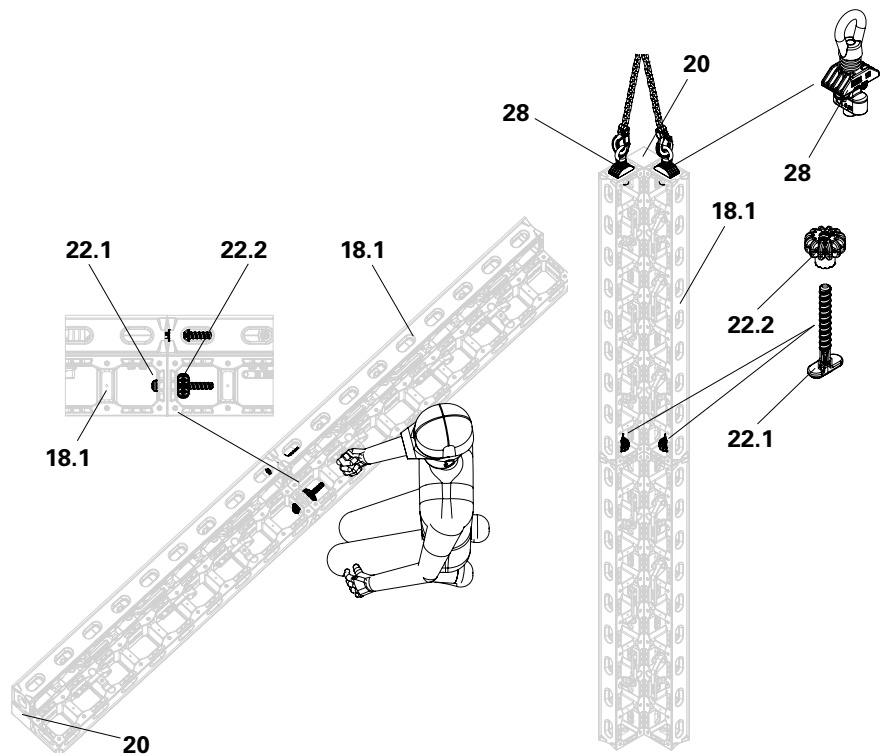

Fig. B5.03

Fig. B5.04

## 90° corners

Wall thicknesses of 15 – 40 cm can be formed in 1 cm increments.  
 For increments of 5 cm, see (Fig. B5.05 – Fig. B5.05e).  
 Reference height: 2.70 m.  
 Corner assembly with the DC 60 panel takes place in the same way.

### Required components:

<b>20</b>	DC 135 x 10 corner post	4x
<b>11.1</b>	DP 135 x 15 panel	4x
<b>12.1</b>	DMP 135 x 45 multi panel	4x
<b>13</b>	DWC 135 x 5 wall thickness compensator	4x
<b>13.1</b>	DWC 135 x 6 wall thickness compensator	4x
<b>13.2</b>	DWC 135 x 10 wall thickness compensator	4x
<b>25</b>	DUO 62 compensation waler	8x
<b>24</b>	DUO tube holder	16x

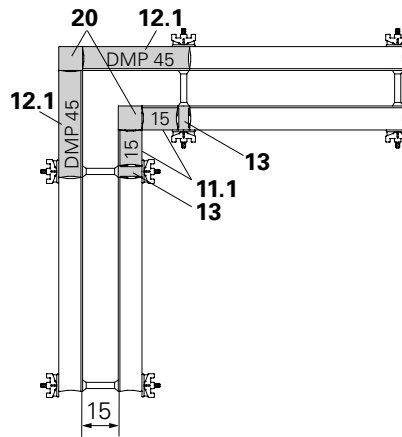

Fig. B5.05

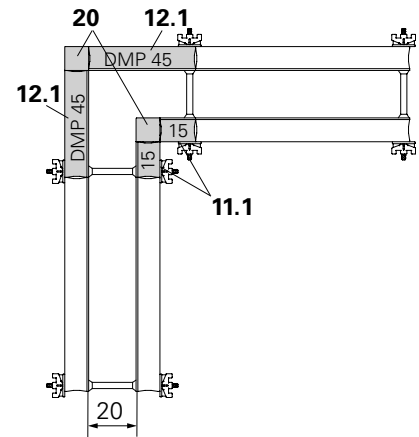

Fig. B5.05a

## Compensations

For external and internal formwork, the DWC wall thickness compensator (**13**) should always be installed between the last wall panel and the corner panel.

The tie point of the wall thickness compensator should always be installed opposite the corner post.

With wall thickness compensators DWC 7, 8, 9, 10, always use compensation waler DUO 62 (**25**). (Fig. B5.05e)

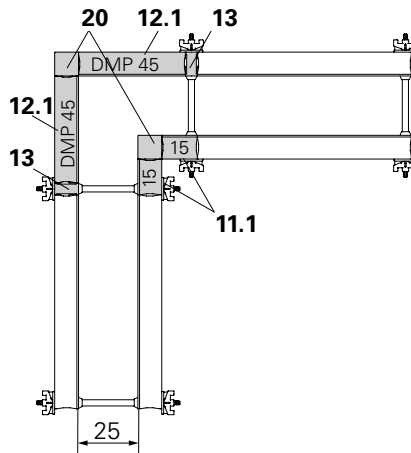

Fig. B5.05b

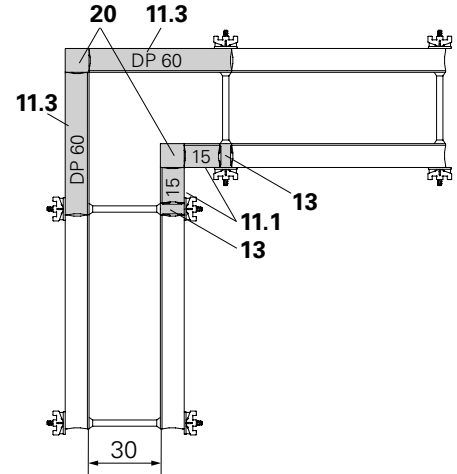

Fig. B5.05c

## Required components:

- 11.1** DP 135 x 15 panel
- 11.3** DP 135 x 60 panel
- 12.1** PMP 135 x 45 multi panel
- 13** DWC 135 x 5 wall thickness compensator
- 13.2** DWC 135 x 9 wall thickness compensator
- 20** DC 135 x 10 corner post
- 24** DUO tube holders
- 25** DUO compensation waler

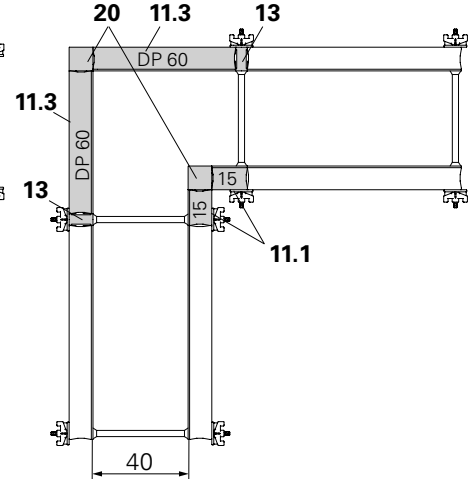
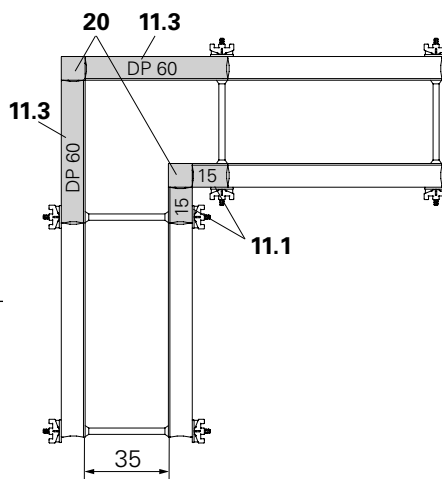

Fig. B5.05d

## Height extensions with DFP filler panels

For height extensions with DFP filler panels, wall thicknesses in 5 cm increments are possible. The dimensions of the DFP filler panels are to be selected in the same way as standard panels

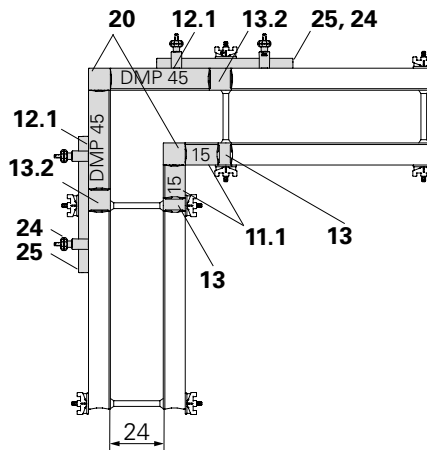

Fig. B5.05e

## Corner panels

### Internal formwork

- without wall thickness compensation

#### Required components:

<b>20</b>	DC 135 x 10 corner post	2x
<b>11.1</b>	DP 135 x 15 panel	4x
<b>22</b>	DUO coupling tie	2x
<b>21</b>	DUO coupler**	28x
<b>21a</b>	DUO coupler to next DP panel**	12x

(Fig. B5.06)

- with wall thickness compensation

#### Required components:

<b>20</b>	DC 135 x 10 corner post	2x
<b>11.1</b>	DP 135 x 15 panel	4x
<b>13</b>	DWC 135 x * wall thickness compensator	4x
<b>22</b>	DUO coupling tie	2x
<b>21</b>	DUO coupler**	44x
<b>21a</b>	DUO coupler to next DP panel**	12x

(Fig. B5.06a)

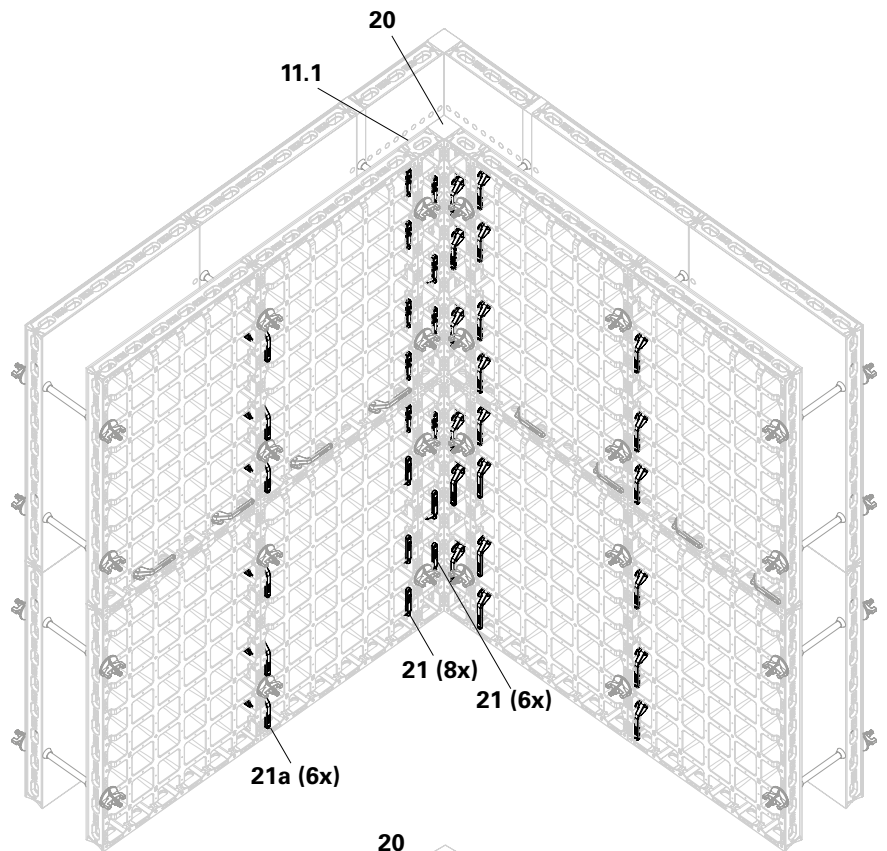

Fig. B5.06

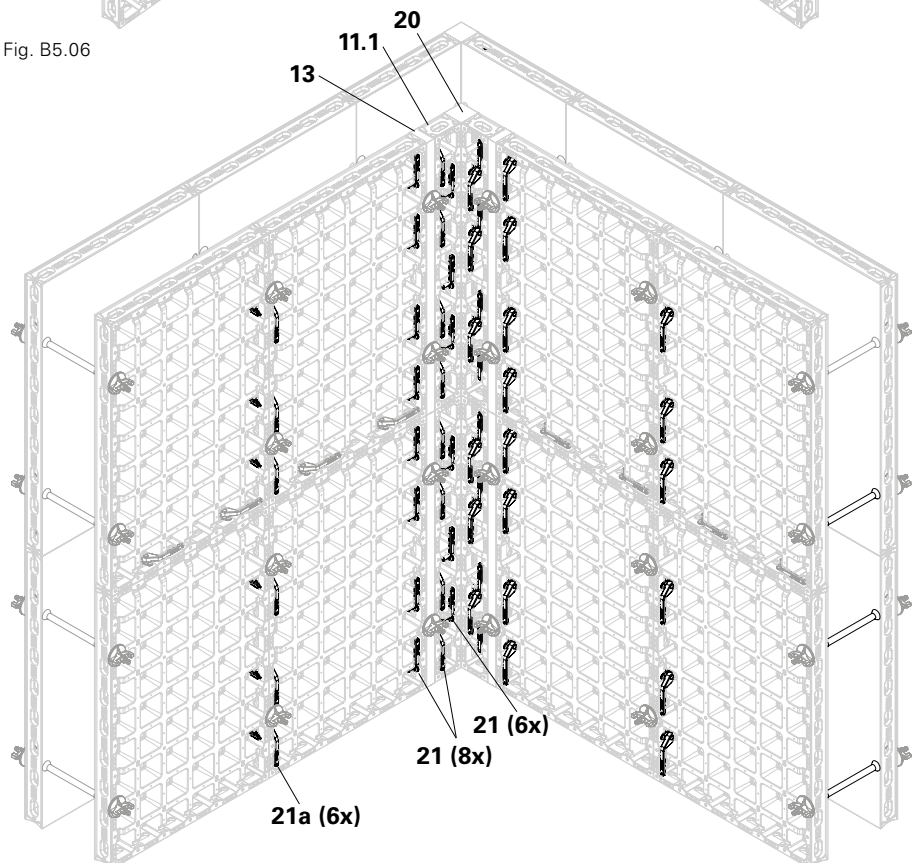

Fig. B5.06a

\* Dependent on wall thickness.

\*\* Not taking into account horizontal connections.

## External formwork

- without wall thickness compensation

### Required components:

<b>20</b>	DC 135 x 10 corner post	2x
<b>11.3</b>	DC 135 x 60* panel	4x
<b>21</b>	DUO coupler**	32x
<b>21a</b>	DUO coupler to next DP panel**	12x

(Fig. B5.07)

- with wall thickness compensation

### Required components:

<b>20</b>	DC 135 x 10 corner post	2x
<b>12.1</b>	DMP 135 x 45* multi panel	4x
<b>13</b>	DWC 135 x* wall thickness compensator	4x
<b>21</b>	DUO coupler**	48x
<b>21a</b>	DUO coupler to next DP panel**	12x

(Fig. B5.07a)

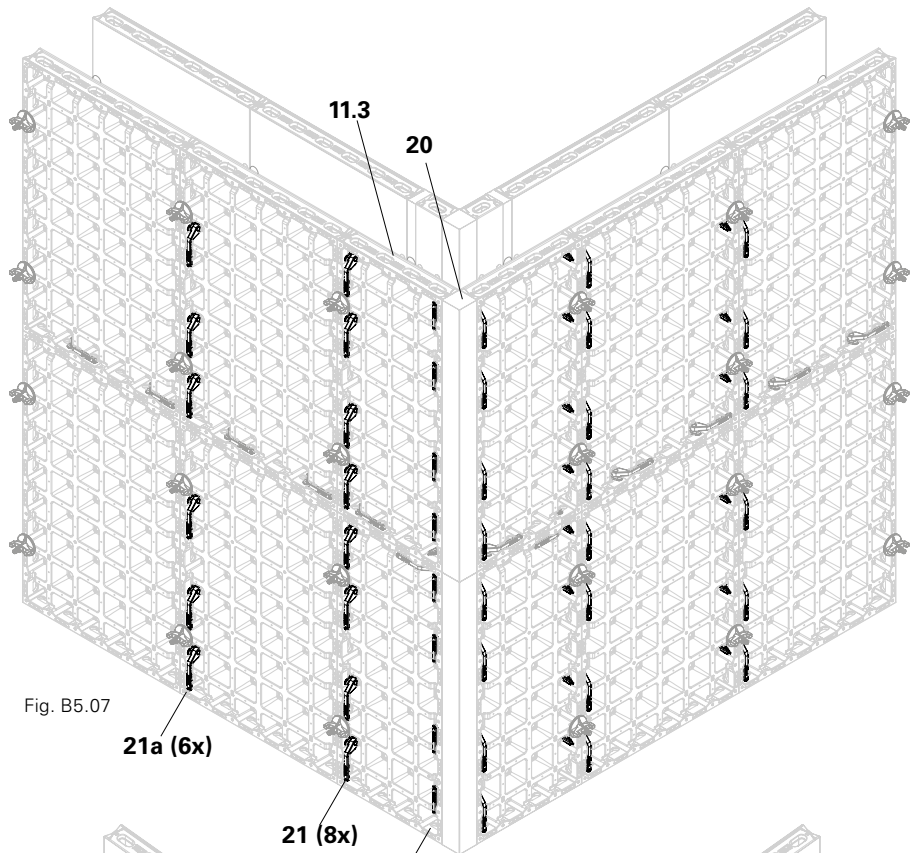

Fig. B5.07

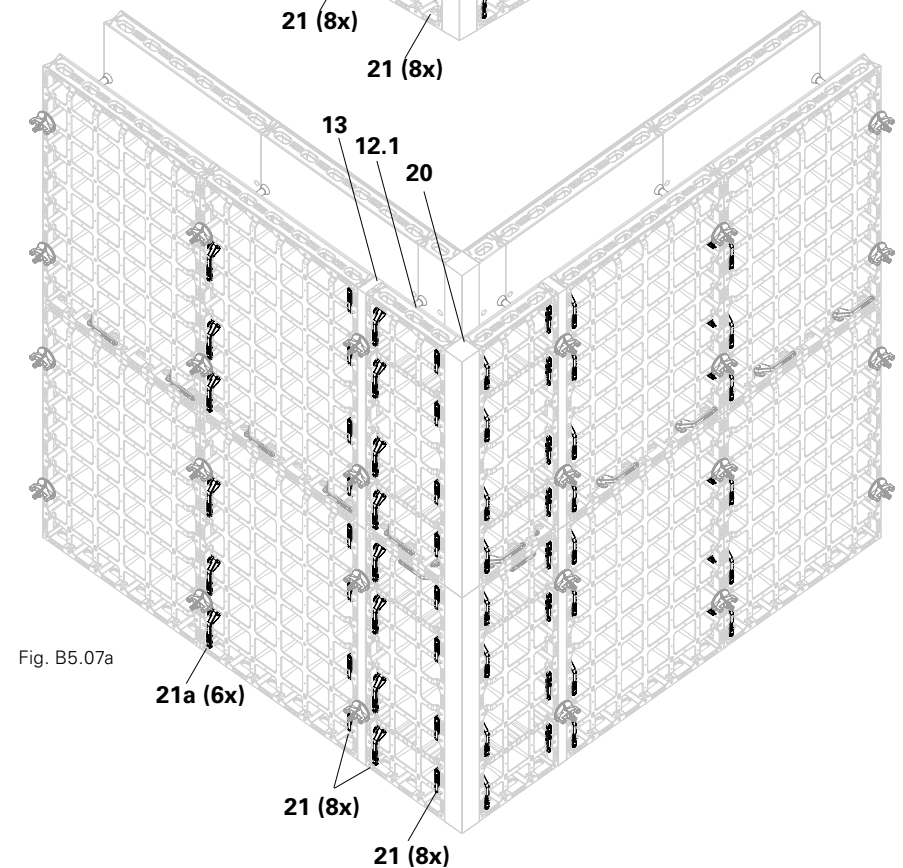

Fig. B5.07a

\* Dependent on wall thickness.

\*\* Not taking into account horizontal connections.

## Height extensions using DP 60 panels

### Internal formwork

- without wall thickness compensation

#### Required components:

20.1 DC 60 x 10 corner post	1x
18.1 DP 60 x 15 panel	2x
22 DUO coupling tie	2x
21 DUO coupler**	6x
21a DUO coupler to next DP panel**	4x

(Fig. B5.08)

- with wall thickness compensation

#### Required components:

20.1 DC 60 x 10 corner post	1x
18.1 DP 60 x 15 panel	2x
14 DWC 60 x* wall thickness compensator	2x
22 DUO coupling tie	2x
21 DUO coupler**	10x
21a DUO coupler to next DP panel**	4x

(Fig. B5.08a)

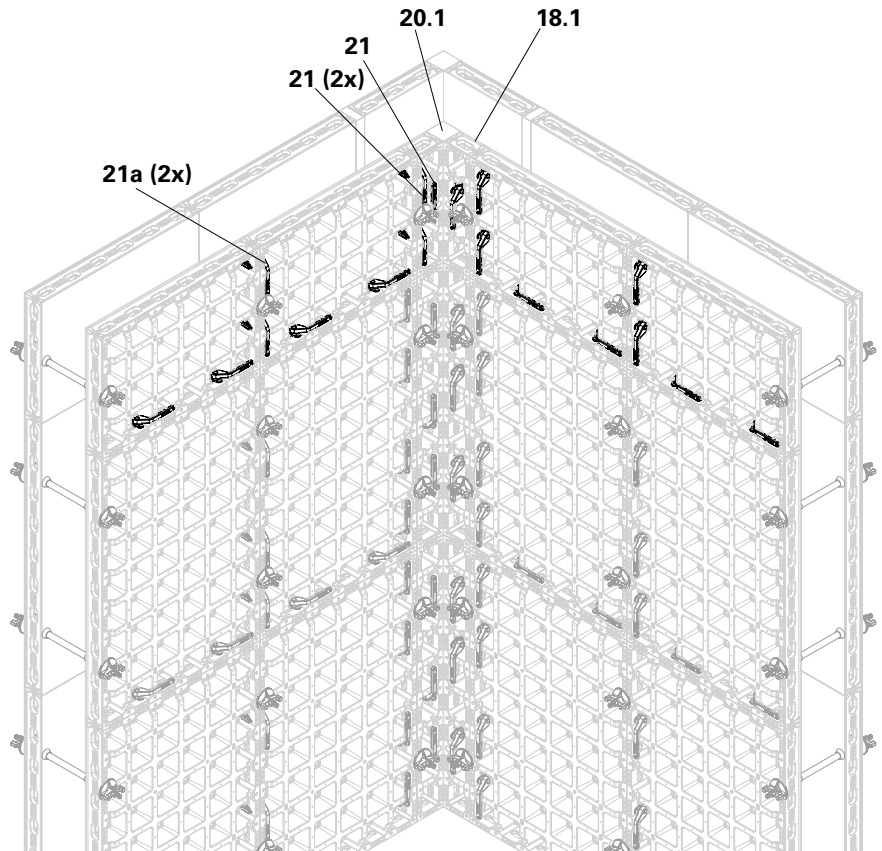

Fig. B5.08

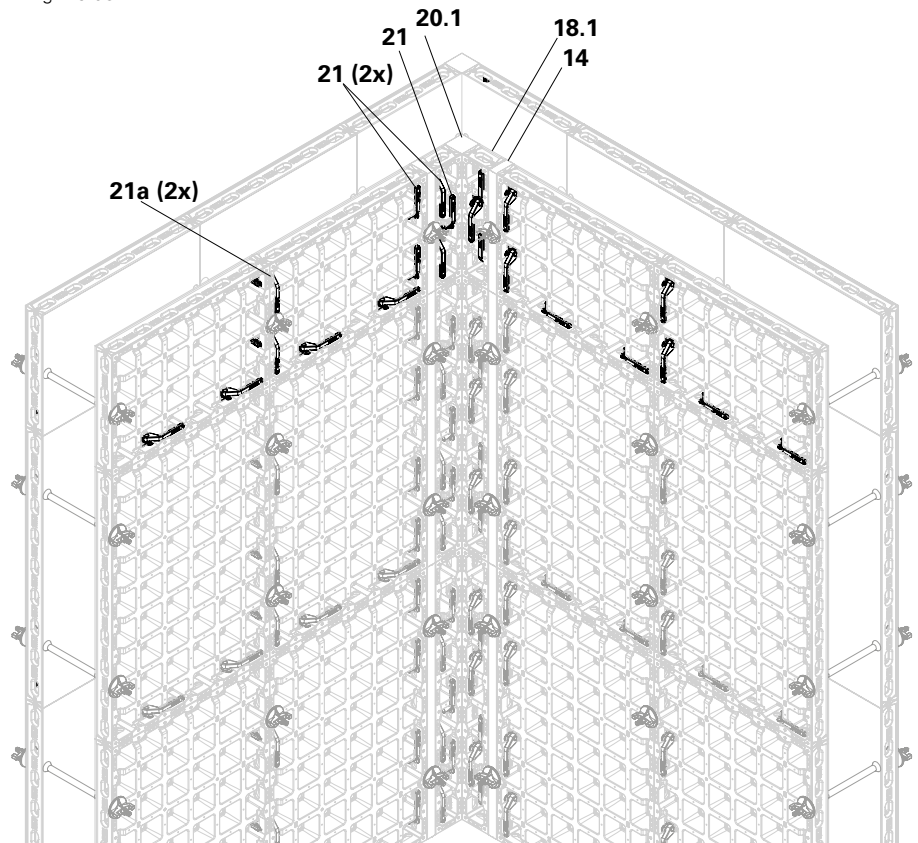

Fig. B5.08a

\* Dependent on wall thickness.

\*\* Not taking into account horizontal connections.

## External formwork

- with wall thickness compensation

### Required components:

<b>20.1</b> DC 60 x 10 corner post	1x
<b>19.1</b> DMP 60 x 45* multi panel	2x
<b>14</b> DWC 60 x* wall thickness compensator	2x
<b>21</b> DUO coupler**	12x
<b>21a</b> DUO coupler to next DP panel**	8x

(Fig. B5.09)

- without wall thickness compensation

### Required components:

<b>20.1</b> DC 60 x 10 corner post	1x
<b>18.3</b> DC 60 x 60* panel	2x
<b>21</b> DUO coupler**	8x
<b>21a</b> DUO coupler to next DP panel**	4x

(Fig. B5.09a)

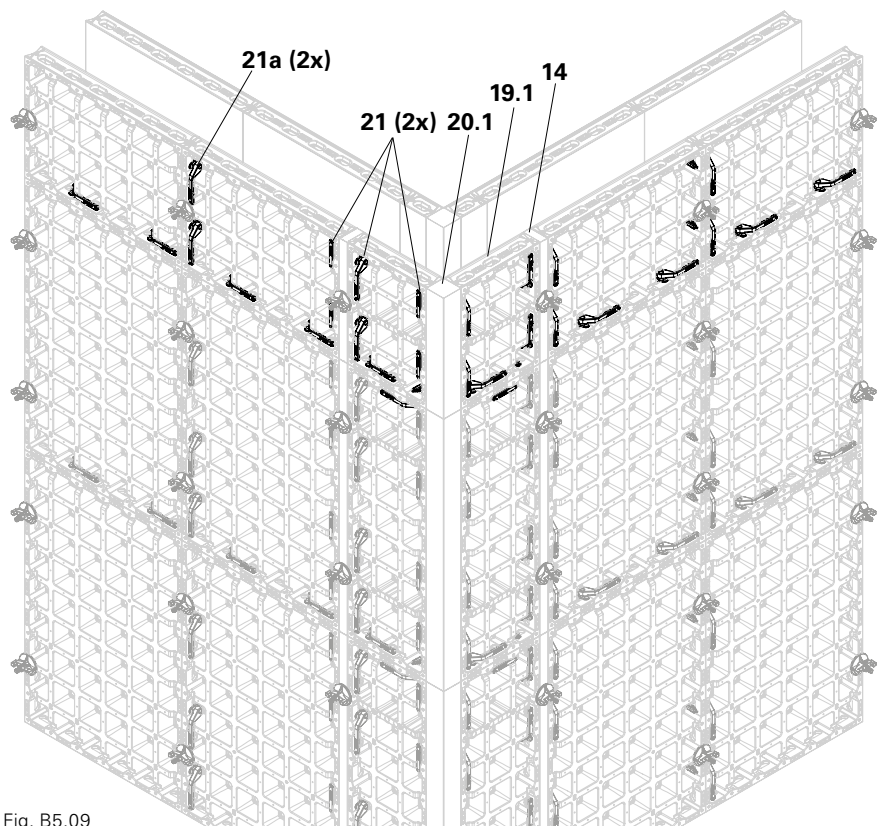

Fig. B5.09

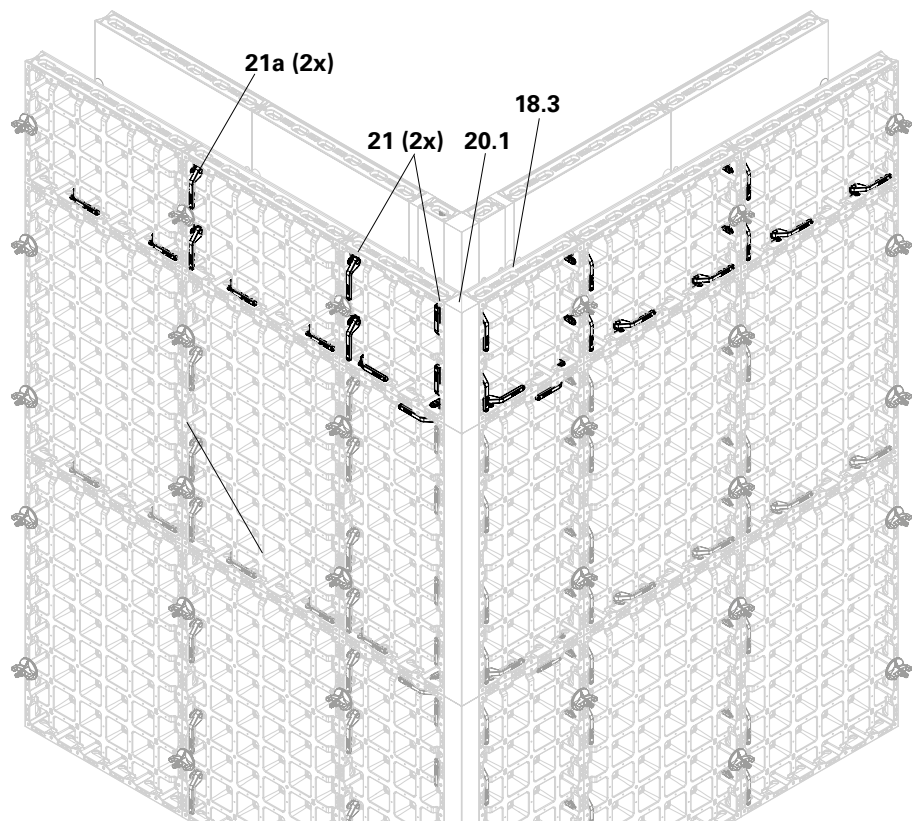

Fig. B5.09a

\* Dependent on wall thickness.

\*\* Not taking into account horizontal connections.

## Height extensions using filler panels

DFP 15 x 10 filler panels (**17.2**) are connected together when 2 or 3 rows of DFP filler panels (**17**) are used for height extensions.

(Fig. B5.10)

DFP filler panels (**17**) can be used for all standard applications.

Other uses are

- internal corners (Fig. B5.10a)
- external corners (Fig. B5.10b)
- wall thickness compensation 10 cm (Fig. B5.10c)

At internal and external corners, with or without wall thickness compensation, one DUO coupler is always used to establish the vertical joint connection. The DFP 15 x 5 filler panel (**17.1**) and DFP 15 x 10 (**17.2**) filler panel only have one connector pocket on the vertical joint.

Installing DFP 15 x 10 filler panels (**17.2**) as a corner.

Installing DFP 15 x 5 filler panels (**17.1**) as wall thickness compensation.

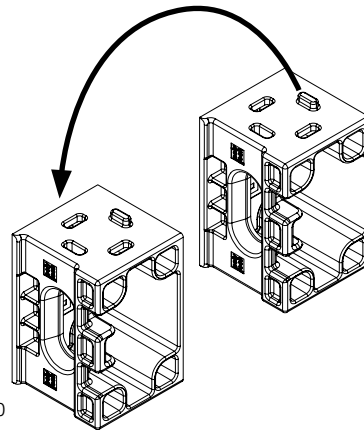

Fig. B5.10

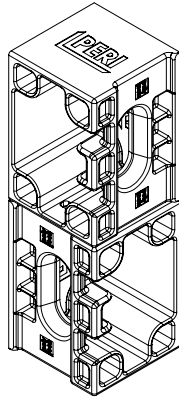

Fig. B5.10a

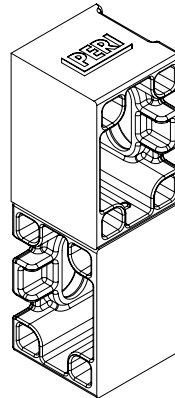

Fig. B5.10b

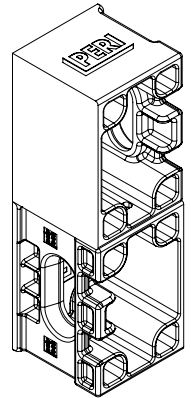

Fig. B5.10c

## 1 row

### Internal formwork

#### Required components:

<b>17.2</b>	DFP 15 x 10 filler panel	1x
<b>17.3</b>	DFP 15 x 15 filler panel	2x
<b>21</b>	DUO coupler**	3x

(Fig. B5.11)

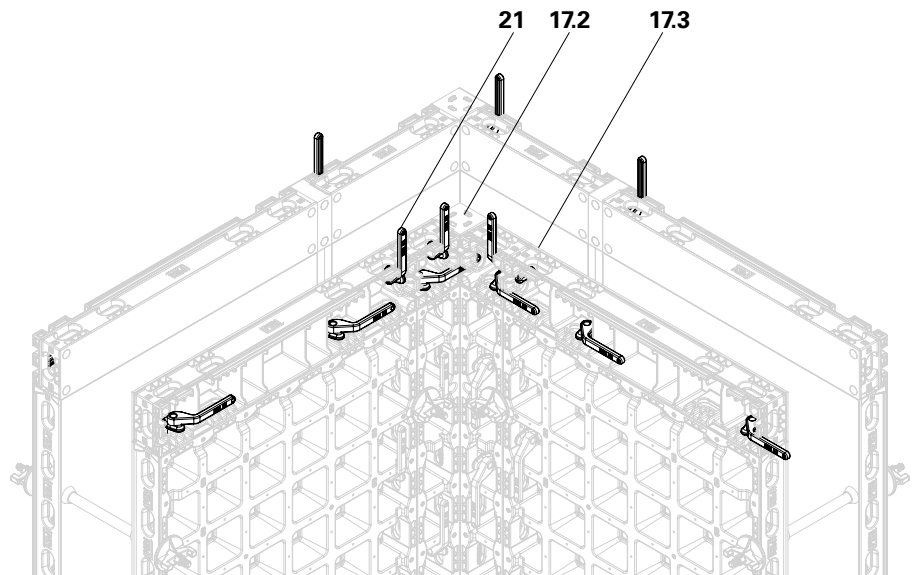

Fig. B5.11

\*\* Not taking into account horizontal connections.

## External formwork

### Required components:

17.2	DFP 15 x 10 filler panel	1x
17.4	DFP 15 x 45* filler panel	2x
17.1	DFP 15 x 5 filler panel	2x
21	DUO coupler**	3x

(Fig. B5.11a)

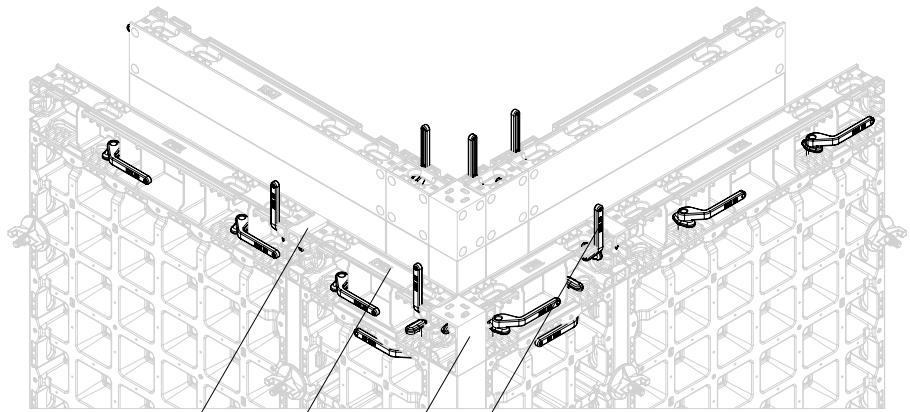

Fig. B5.11a

## 2 rows

### Internal formwork

### Required components:

17.2	DFP 15 x 10 filler panel	2x
17.3	DFP 15 x 15 filler panel	4x
21	DUO coupler**	5x

(Fig. B5.12)

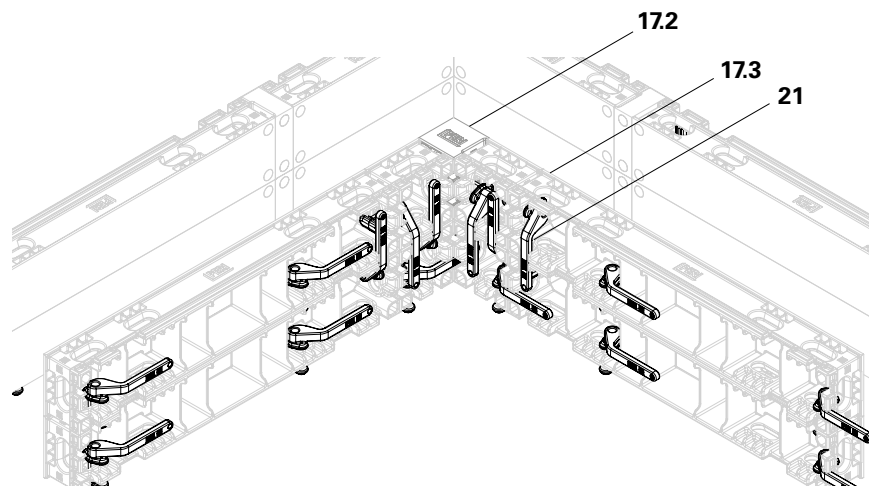

Fig. B5.12

## External formwork

### Required components:

17.2	DFP 15 x 10 filler panel	2x
17.4	DFP 15 x 45* filler panel	4x
17.1	DFP 15 x 5 filler panel	4x
21	DUO coupler**	6x

(Fig. B5.12a)

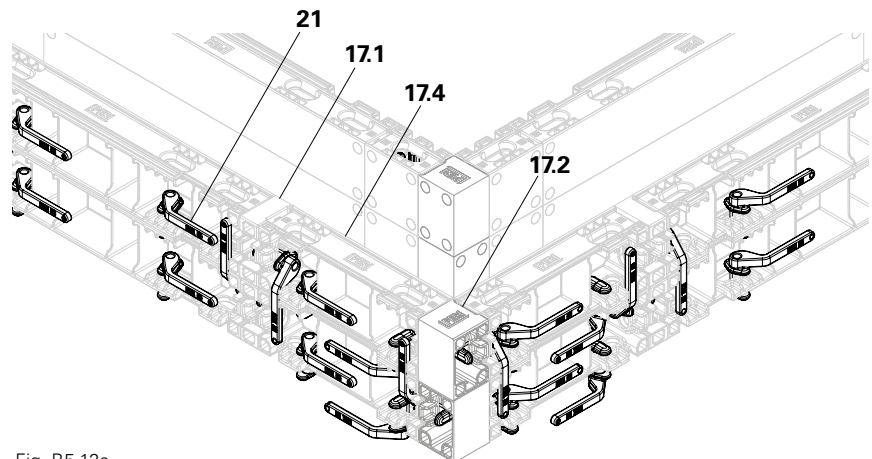

Fig. B5.12a

## 3 rows

In the third row of height extensions, the DUO couplers are used as in the first row.

In addition, ties are installed (see section B10 Height extensions, tie positions for DFP filler panels).

\* Dependent on wall thickness.

\*\* Not taking into account horizontal connections.

## Alternative formwork for external corners

With the PERI DUO system, it is possible to form external corners using DMP multi panels (12) and DUO corner connectors (23).

Reference height 2.70 m.  
(Fig. B5.13 + Fig. B5.14)

### Required components:

12.2	DMP 75 multi panel	2x
(12.1)	DMP 45 multi panel	2x
or		
18	DP 60 panel	2x
23.1	DUO corner connector	4x
23.2	DUO corner tie	4x
54	Wingnut counterplate DW 15	4x

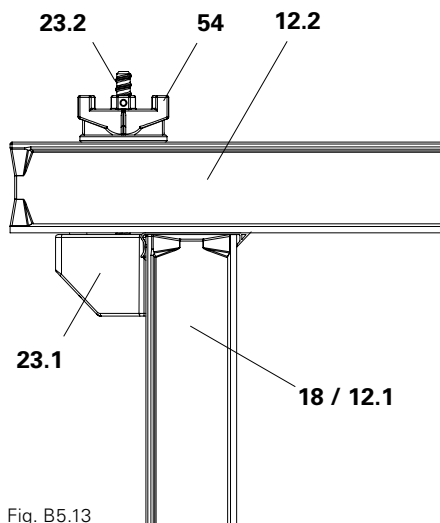

Fig. B5.13

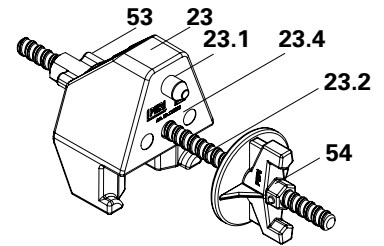

Fig. B5.14

### Installation

1. Disassemble the DUO corner connector (23), screw the cam nut (53) onto the corner tie (23.2).
2. Position the DMP 75 multi panel (12.2) in front of the last DMP multi panel at a right angle. (Fig. B5.15)
3. Insert the DUO corner connector (23.1) into the frame strut of the DMP multi panel. (Fig. B5.15a)
4. Insert the steel pin (23.4) of the DUO corner connector into the appropriate tie point (10.1) of the DMP multi panel (12). (Fig. B5.15b)
5. Push the DUO corner tie (23.2) through the DUO corner connector (23.1) and the DMP multi panel (12). (Fig. B5.15b)
6. Tighten with the DW 15 wingnut counterplate (54) from the rear by hand or with the DUO cleaning device (8). (Fig. B5.15c + Fig. B5.15d)

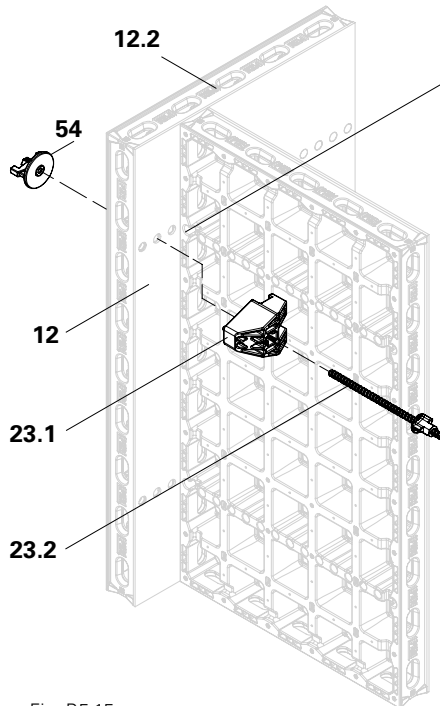

Fig. B5.15

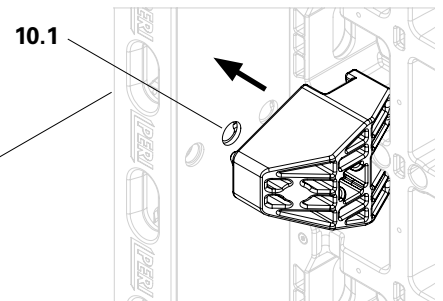

Fig. B5.15a

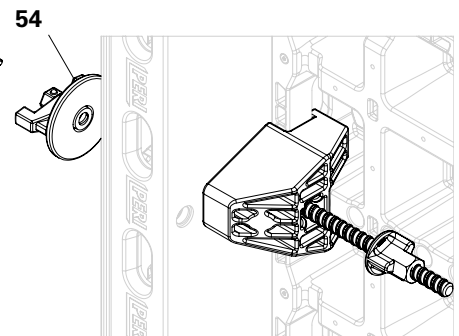

Fig. B5.15b

### Arrangement of DUO couplers

Use 4 DUO couplers to connect the next DMP multi panel or wall thickness compensator to the following panel, see External formwork. (Fig. B5.06 + Fig. B5.06a)

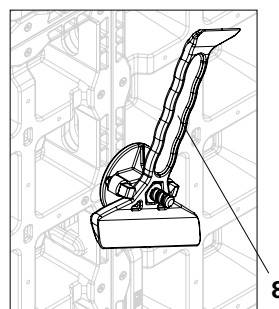

Fig. B5.15d

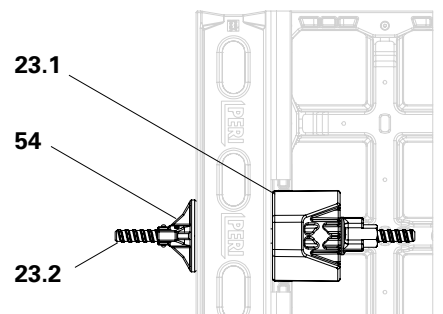

Fig. B5.15c

## T-junction

Wall thicknesses of 15 – 40 cm can be formed in 1 cm increments.  
For increments of 5 cm, see (Fig. B6.01).

DP 135 panels (10), reference height: 2.70 m.

Assembly with DP 60 panels (18) takes place in the same way.

### Required components:

20	DC 135 x 10 corner post	4x
21	DUO coupler	x*
11.3	DP 135 x 60 panel	2x*
12.2	DMP 135 x 75 multi panel	2x*
11.4	DP 135 x 90 panel	2x*
11.1	DP 135 x 15 panel	8x
13.1	DWC 135 x 5 wall thickness compensator	x*
13.1	DWC 135 x 6 wall thickness compensator	x*

### Compensations

For external and internal formwork, the DWC wall thickness compensator (13) should always be installed between the last wall panel and the corner panel.

### Height extensions with DFP filler panels

For height extensions with DFP filler panels, wall thicknesses in 5 cm increments are possible. The dimensions of the DFP filler panels are to be selected in the same way as standard panels

### Internal formwork

#### Required components:

20	DC 135 x 10 corner post	4x
11.1	DP 135 x 15 panel	8x
21	DUO coupler	48x**

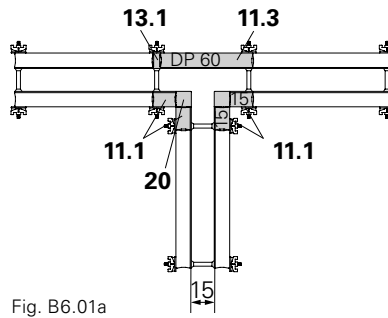

Fig. B6.01a

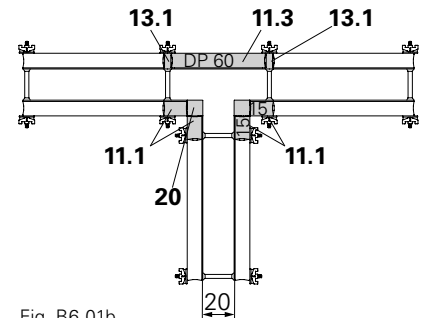

Fig. B6.01b

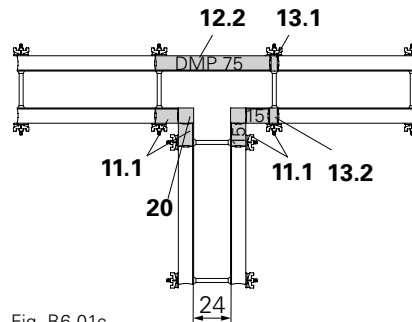

Fig. B6.01c

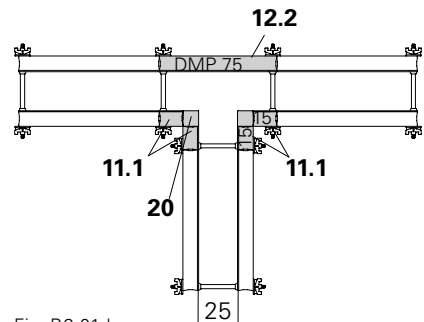

Fig. B6.01d

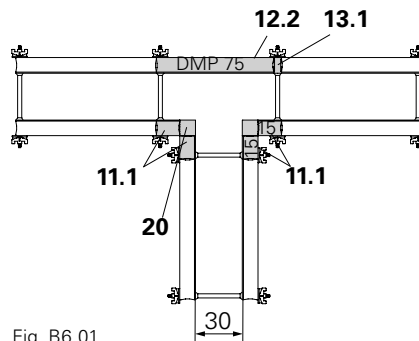

Fig. B6.01e

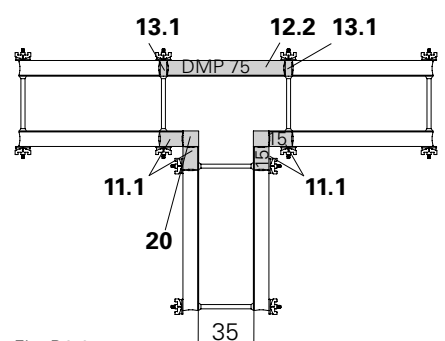

Fig. B6.01f

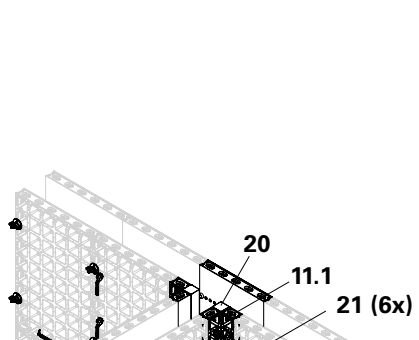

Fig. B6.01g

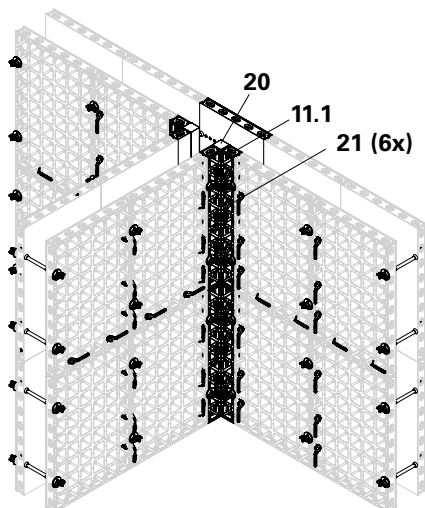

Fig. B6.02

\* Dependent on wall thickness.

\*\* Not taking into account the horizontal connections and the wall thickness compensation.

## External formwork

### Required components:

<b>10</b> DP 135 x 60 – DMP 135 x 75 – DP 135 x 90 panel	2x
<b>13</b> DWC 135 x* wall thickness compensator	x*
<b>21</b> DUO coupler (without DWC)	12x
<b>21</b> DUO coupler (with 1 DWC)	18x
<b>21</b> DUO coupler (with 2 DWC)	24x

(Fig. B6.03)

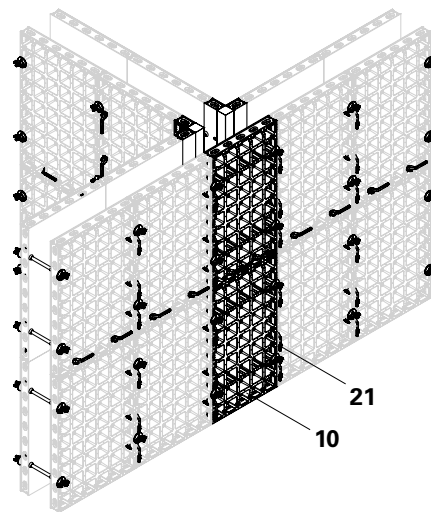

Fig. B6.03

## Obtuse-angle wall connection

### Connection with DMP 135 x 75 multi panel

(Fig. B6.04 + Fig. B6.04a)

Use the second tie point of the DMP multi panel to avoid overlapping of the wingnut counterplate (54) and the wall. Also to be used with the DMP 135 x 45 multi panel.

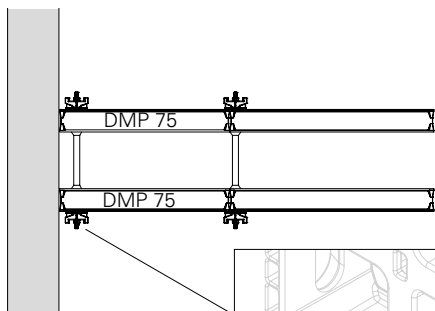

Fig. B6.04

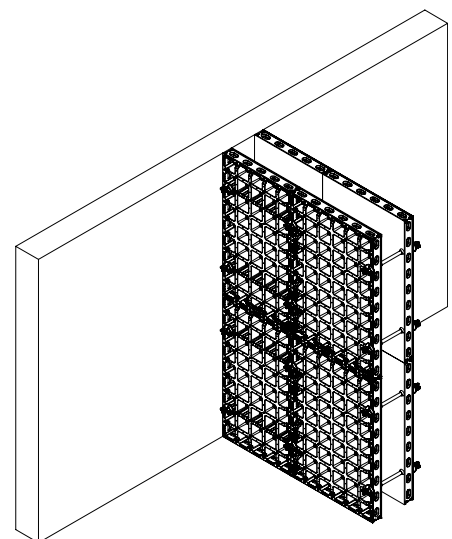

Fig. B6.04a

### Connection with DP 135 x 90 panel

(Fig. B6.05)

Use the cam nut (53) in order to avoid overlapping between the nut and the wall. Also to be used with the DP 135 x 60, 135 x 30, 135 x 15 panels.

(Fig. B6.05a)

Also to be used with the DP 135 x 60, 135 x 30, 135 x 15 panels.

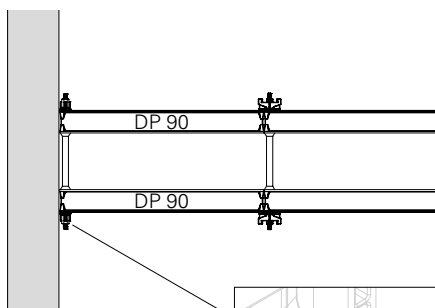

Fig. B6.05

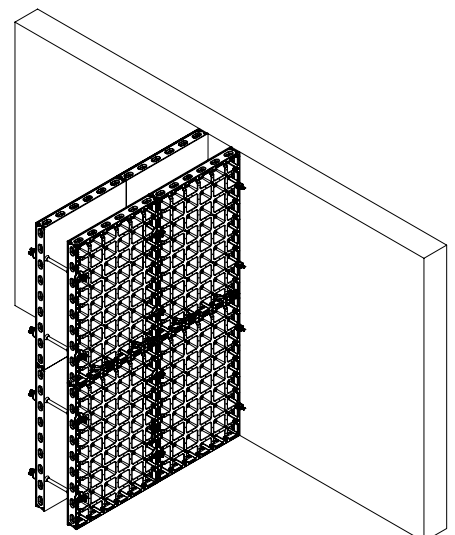

Fig. B6.05a

\* Dependent on wall thickness.

# B7 Wall offsets

## Wall offsets 5 – 35 cm without tie in the wall offset

(Fig. B7.01 + Fig. B7.01a)

### Required components:\*\*

<b>20</b>	DC 135 x 10 corner post	2x
<b>11.1</b>	DP 135 x 15 panel	2x
<b>12.1</b>	DMP 135 x 45 multi panel	2x
<b>12.1</b>	DMP 135 x 45* multi panel	2x
<b>23.1</b>	DUO corner connector	4x
<b>23.2</b>	DUO corner tie	4x
<b>54</b>	DW 15 wingnut counterplate	4x
<b>25</b>	DUO 62 compensation waler	4x
<b>24</b>	DUO tube holder	8x

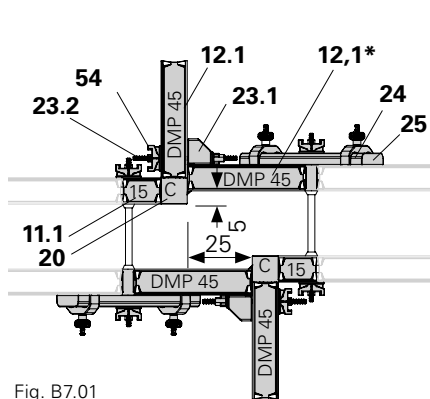

Fig. B7.01

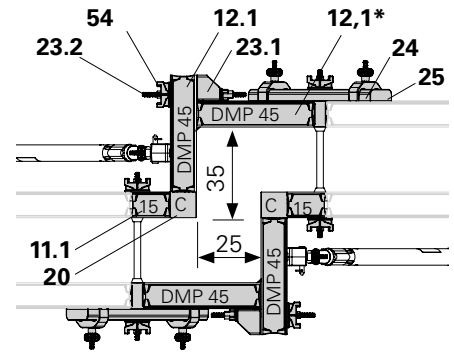

Fig. B7.01a

## Wall offsets 40 – 45 cm without tie in the wall offset

(Fig. B7.02 + Fig. B7.02a)

### Required components:\*\*

<b>20</b>	DC 135 x 10 corner post	2x
<b>11.1</b>	DP 135 x 15 panel	2x
<b>12.2</b>	DMP 135 x 75 multi panel	2x
<b>12.1</b>	DMP 135 x 45* multi panel	2x
<b>23.1</b>	DUO corner connector	4x
<b>23.2</b>	DUO corner tie	4x
<b>54</b>	DW 15 wingnut counterplate	4x
<b>25</b>	DUO 62 compensation waler	4x
<b>24</b>	DUO tube holder	8x

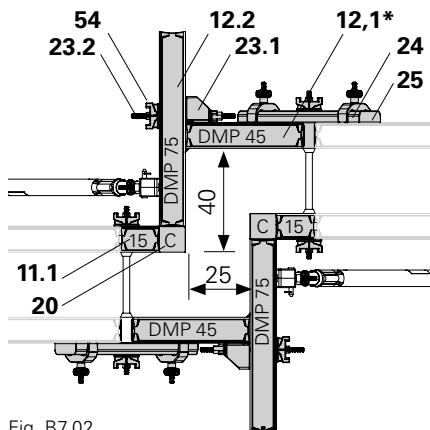

Fig. B7.02

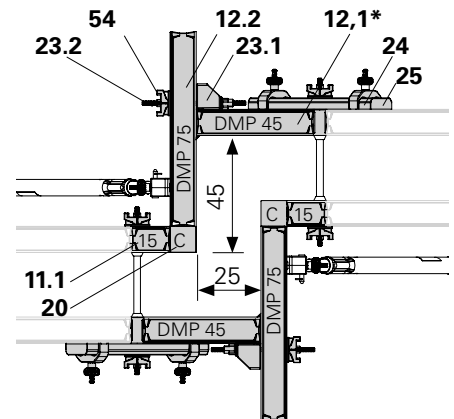

Fig. B7.02a

\* Dependent on wall thickness, see B5 Corners.

\*\* Number per formwork side.

## Wall offsets 50 – 65 cm

### 1x tie in wall offset

(Fig. B7.03+ Fig. B7.03a)

#### Required components:\*\*

<b>20</b>	DC 135 x 10 corner post	2x
<b>11.1</b>	DP 135 x 15 panel	2x
<b>12.2</b>	DMP 135 x 75 multi panel	2x
<b>12.1</b>	DMP 135 x 45* multi panel	2x
<b>23.1</b>	DUO corner connector	4x
<b>23.2</b>	DUO corner tie	4x
<b>54</b>	DW 15 wingnut counterplate	4x
<b>25</b>	DUO 62 compensation waler	4x
<b>24</b>	DUO tube holder	8x

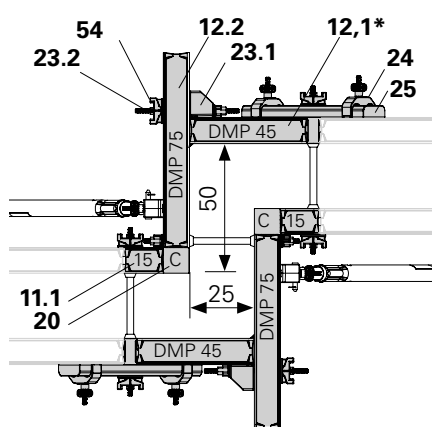

Fig. B7.03

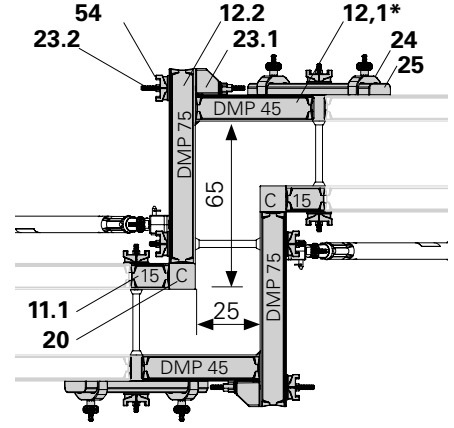

Fig. B7.03a

## Wall offsets 70 – 80 cm

### 1x tie in wall offset

(Fig. B7.04 + Fig. B7.04a)

#### Required components:\*\*

<b>20</b>	DC 135 x 10 corner post	2x
<b>11.1</b>	DP 135 x 15 panel	4x
<b>12.2</b>	DMP 135 x 75 multi panel	2x
<b>12.1</b>	DMP 135 x 45 * multi panel	2x
<b>23.1</b>	DUO corner connector	4x
<b>23.2</b>	DUO corner tie	4x
<b>54</b>	DW 15 wingnut counterplate	4x
<b>25</b>	DUO 62 compensation waler	4x
<b>24</b>	DUO tube holder	8x

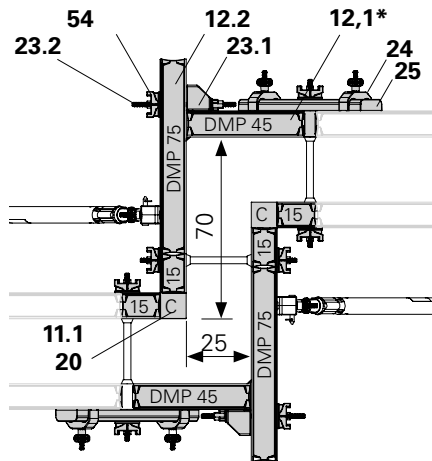

Fig. B7.04

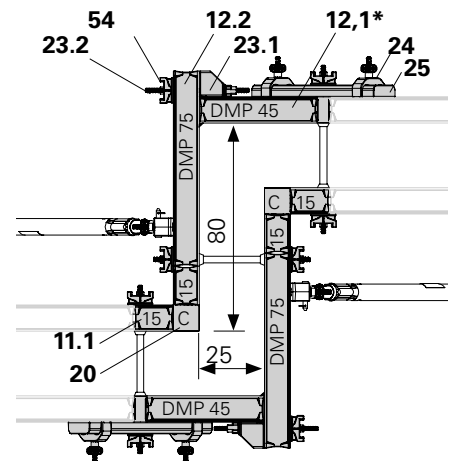

Fig. B7.04a

\* Dependent on wall thickness, see B5 Corners.

\*\* Number per formwork side.

## Wall offsets 85 – 95 cm

### 2x tie in wall offset

(Fig. B7.05 + Fig. B7.05a)

#### Required components:\*\*

20	DC 135 x 10 corner post	2x
11.1	DP 135 x 15 panel	6x
12.2	DMP 135 x 75 multi panel	2x
12.1	DMP 135 x 45* multi panel	2x
23.1	DUO corner connector	4x
23.2	DUO corner tie	4x
54	DW 15 wingnut counterplate	4x
25	DUO 62 compensation waler	4x
24	DUO tube holder	8x

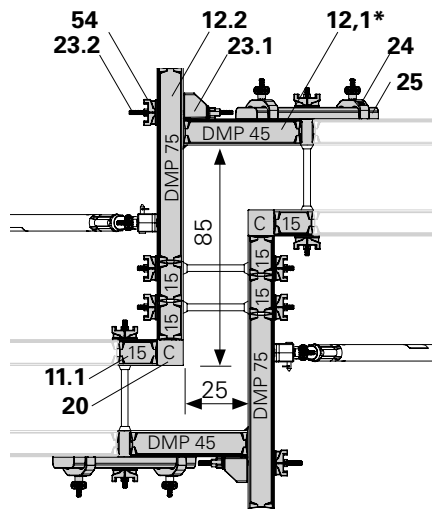

Fig. B7.05

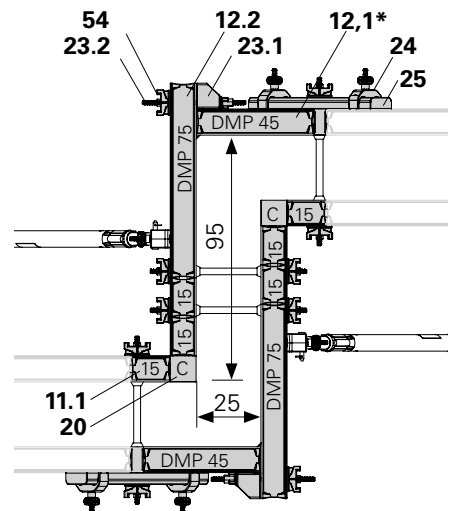

Fig. B7.05a

## Wall offsets 100 – 110 cm

### 2x tie in wall offset

(Fig. B7.06)

#### Required components:\*\*

20	DC 135 x 10 corner post	2x
11.1	DP 135 x 15 panel	4x
11.2	DP 135 x 30 panel	2x
12.2	DMP 135 x 75 multi panel	2x
12.1	DMP 135 x 45* multi panel	2x
23.1	DUO corner connector	4x
23.2	DUO corner tie	4x
54	DW 15 wingnut counterplate	4x
25	DUO 62 compensation waler	4x
24	DUO tube holder	8x

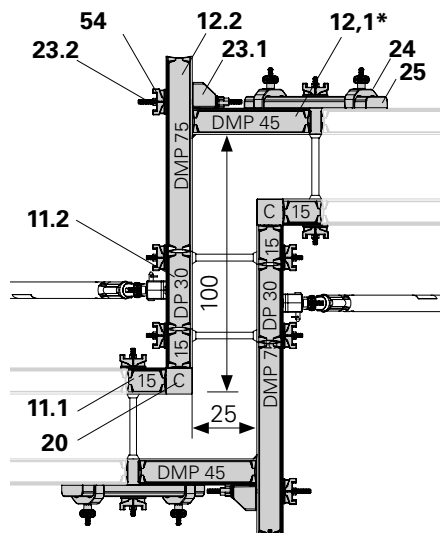

Fig. B7.06

\* Dependent on wall thickness, see B5 Corners.

\*\* Number per formwork side.

**Wall offsets 100 + x cm**  
**2x tie in wall offset**  
 (Fig. B7.07)

**Required components:**

**Wall offset**  
 (cm)

Wall offset (cm)	Panel type
100 – 110	DP 135 x 30 panel
115 – 125	DP 135 x 45 multi panel
130 – 140	DP 135 x 60 panel

To enlarge the wall offset, exchange the DP 135 x 30 panels (**11.2**).

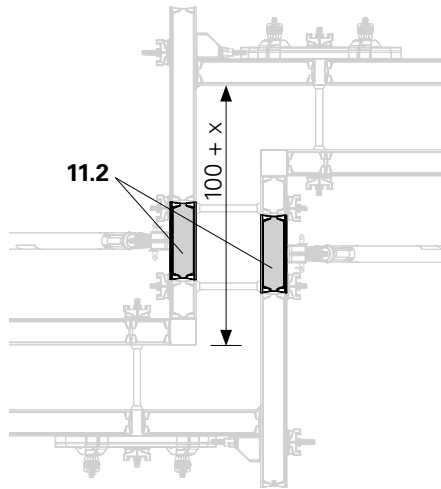

Fig. B7.07

**Wall offset overview**

Figure ( Fig. B7.08) shows an example with a wall offset of 70 cm.

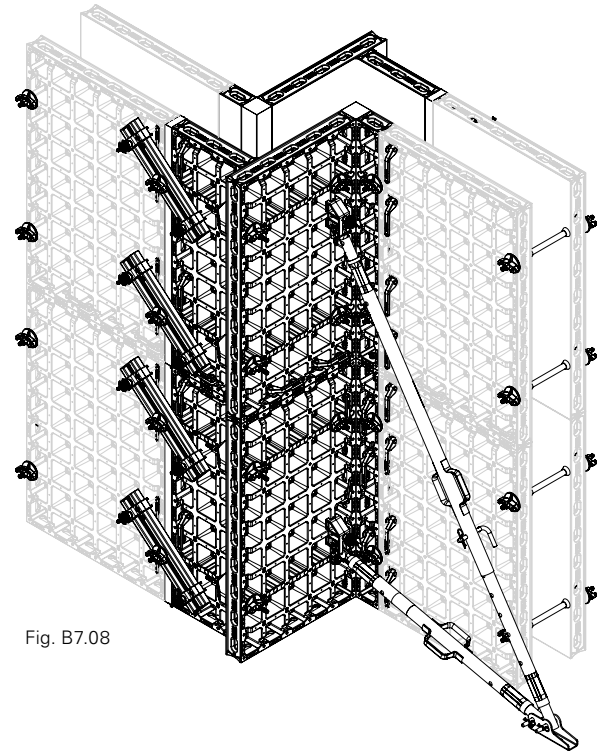

Fig. B7.08

## Arrangement of DUO couplers

For every wall offset, the DUO couplers have to be arranged according to figure (Fig. B7.09) and the table below.

### Required components:

<b>21</b>	DUO coupler	Rows	
	8	2	16
	6	4	24
	Sum**	40	

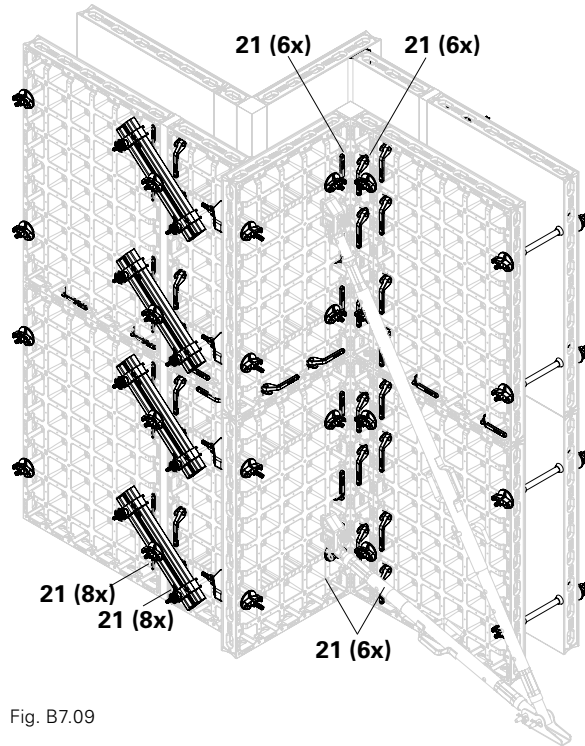

Fig. B7.09

\*\* Not taking into account horizontal connections and number per formwork side.

## Longitudinal infill

PERI DUO allows for length compensations using the DWC wall thickness compensator as well as square timber.

Length compensations  $\leq 5$  cm are realised using cut-to-size timber, the DUO coupling tie (**22**) and the DUO 62 compensation waler (**25**), see section A3. (Fig. B8.01d + Fig. B8.01a)

Use the DWC wall thickness compensator (**13**) and DUO coupler (**21**) to compensate for lengths from 5 cm to 10 cm in 1 cm increments. (Fig. B8.01e + Fig. B8.01c)

Use 18 DFS 135 filler support (**16**) combined with the 18 mm filler plate and DUO coupler (**21**) to compensate for lengths from 9 cm to 25 cm. (Fig. B8.01f + Fig. B8.01c)

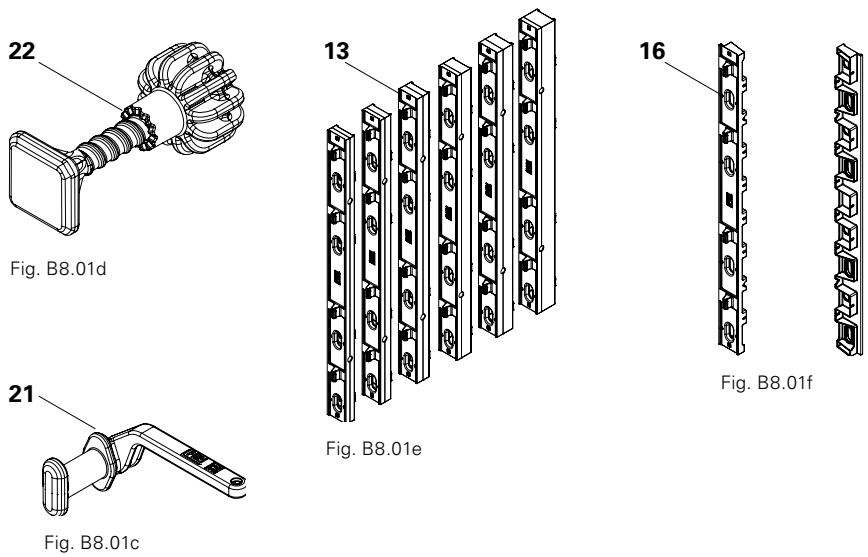

## Longitudinal infill up to 5 cm

### Caution

Reduced holding force of the square timber.

Anchoring through the timber is not permitted.

⇒ Use the tie point (**10.1**) of the panel. (Fig. B8.01c)

⇒ Insert the tie rod (**50**) through the centre section of the DUO 62 compensation waler (**25**). (Fig. B8.01b)

### Required components:

<b>91</b>	Square timber* x 10 cm	1x
<b>22</b>	DUO coupling tie	6x
<b>25</b>	DUO 62 compensation waler	4x
<b>24</b>	DUO tube holder	8x
<b>50</b>	DW 15 tie rod	4x
<b>54</b>	DW 15 wingnut counterplate	4x

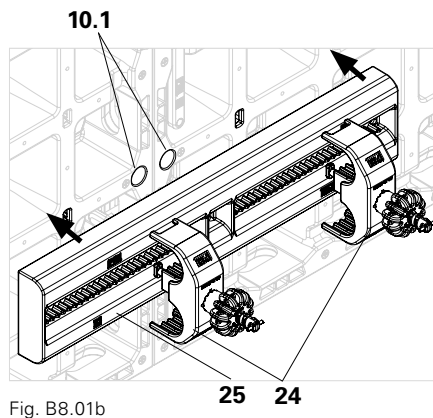

Fig. B8.01b

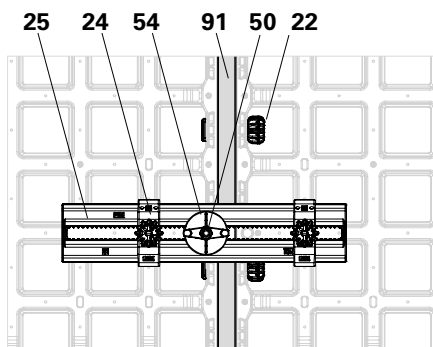

Fig. B8.01a

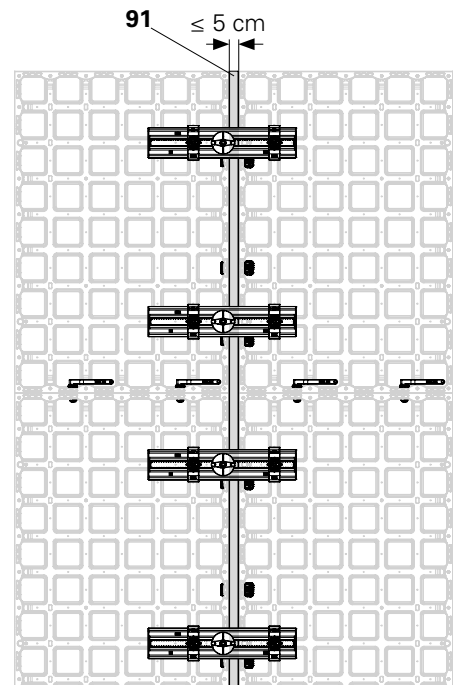

Fig. B8.01

\* Lengths from 1 to 5 cm.  
(Fig. B8.01 – Fig. B8.01b)

## Longitudinal infill from 5 cm to 10 cm

With DWC wall thickness compensator (13). (Fig. B8.02)



### Caution

The component may end up being subjected to excessive loads!

The component could collapse!

⇒ For length compensation  $\geq 7$  cm, fit the DUO 62 compensation waler with the DUO tube holder!

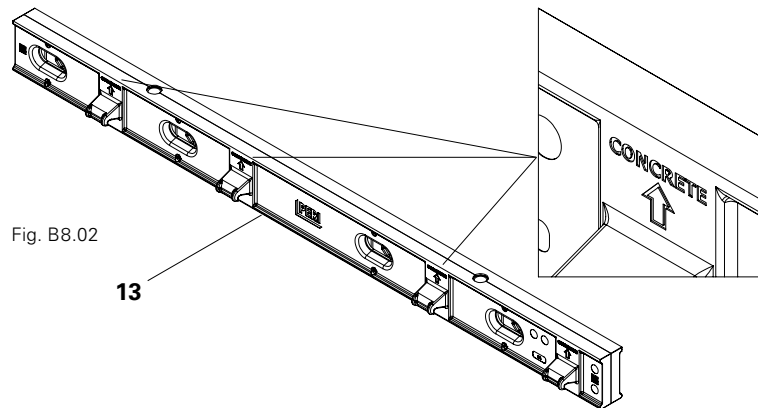

Fig. B8.02

13



Follow the mounting direction of the DWC wall thickness compensator (13). Thereby it is possible to:

- transfer the concrete pressure to the DP panels (10),
- start striking the formwork on the panel,
- mount the DUO couplers (21) as shown in the arrangement.

The DWC wall thickness compensator (13) is equipped with teeth (13.1) that grip into the connector pockets (10.2) of the panel (10). The teeth must point away from the concrete.

(Fig. B8.03 + Fig. B8.03a)

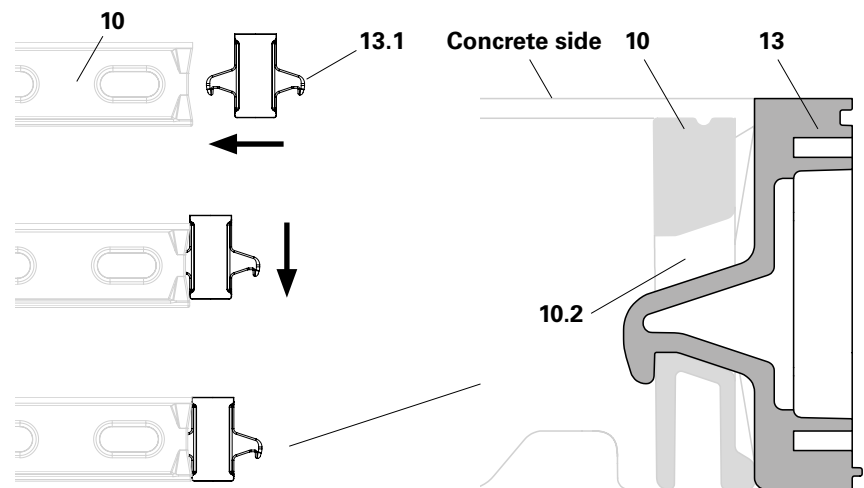

Fig. B8.03

Fig. B8.03a

# B8 Length compensation

## Required components:

<b>13</b>	DWC wall thickness compensator	2x
<b>21</b>	DUO coupler	12x
<b>25</b>	DUO 62 compensation waler	4x
<b>24</b>	DUO tube holder	8x
<b>50</b>	DW 15 tie rod	4x
<b>54</b>	DW 15 wingnut counterplate	4x

### Assembly 7 – 10 cm

1. Mount DWC wall thickness compensator (**13**) on the right and left DP panel (**10**) using 6 DUO couplers (**21**) each.  
(Fig. B8.04 + Fig. B8.05)
2. Attach DUO 62 compensation waler (**25**) to the DUO tube holder (**24**) to compensate lengths  $\geq 7$  cm.
3. Insert tie rod (**50**) through the DWC wall thickness compensator (**13**).  
(Fig. B8.05)

The DW 15 wingnut counterplate (**54**) must cover the frames of the adjacent DP panels by at least 12 mm. If not, mount compensation waler DUO 62 (**25**)!

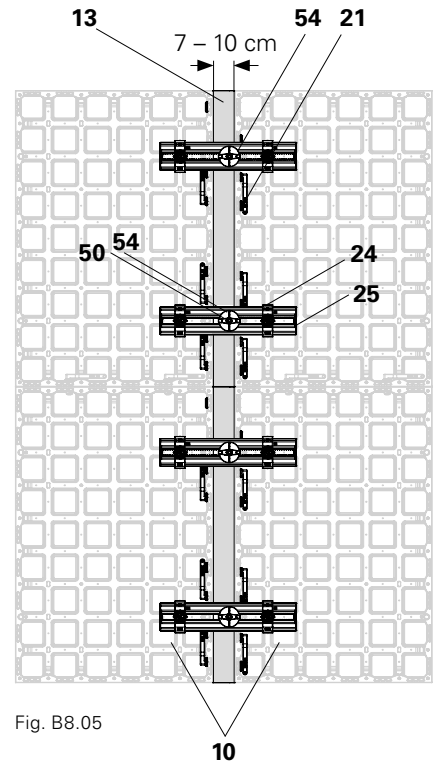
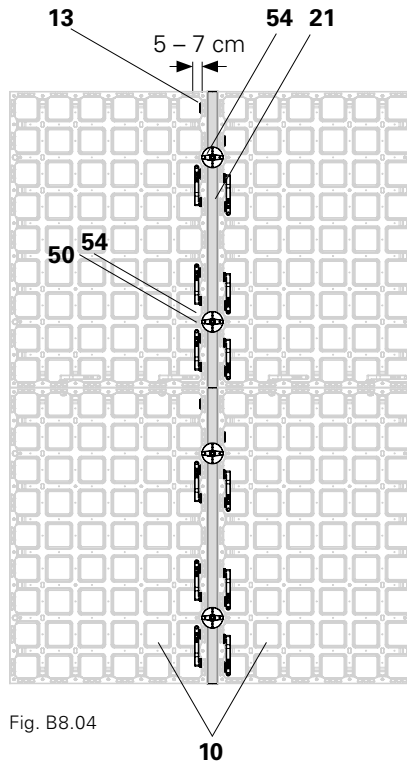

# B8 Length compensation

## Longitudinal infill up to 25 cm

With the 18 DFS 135 x 4.5 filler support (16) and filler plate (90).



### Caution

The component may end up being subjected to excessive loads!

The component could collapse!

⇒ Cuts larger than 25 cm are not permitted!

⇒ Install compensation panels.



Follow the mounting direction of the filler support (16). Thereby it is possible to:

- transfer the concrete pressure to the panels,
- start striking the formwork on the panel,
- mount the DUO couplers (21) as shown in the arrangement.

The filler support (16) is equipped with teeth that grip into the connector pockets (10.2) of the panel. The teeth must point away from the concrete (10.7), see DWC wall thickness compensator. (Fig. B8.02 + Fig. B8.03)

### Required components:

60	18 mm filler plate	1x
16	18 DFS 135 filler support	4x
25	DUO 62 compensation waler	4x
24	DUO tube holder	8x
21	DUO coupler	12x
50	DW 15 tie rod	8x
54	Wingnut counterplate	8x

### Installation

1. Mount the filler support (16) on both panels using 6 DUO couplers (21) each! (Fig. B8.06a)
2. Cut the 18 mm filler plate (60) 2 cm narrower than the length to be compensated. Insert the filler plate. From outside, tighten the Torx 5 x 15 screws through the screw holes provided in the filler support.
3. Install compensation waler DUO 62 (25) with DUO tube holder (24).
4. Guide the tie through the tie points of the panel (54). (Fig. B8.06b + Fig. B8.06c)

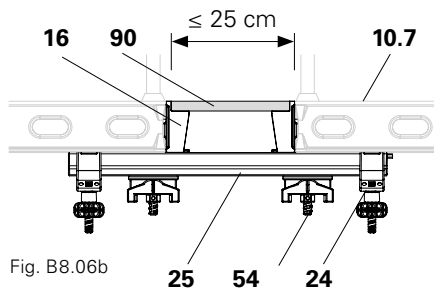

Fig. B8.06b

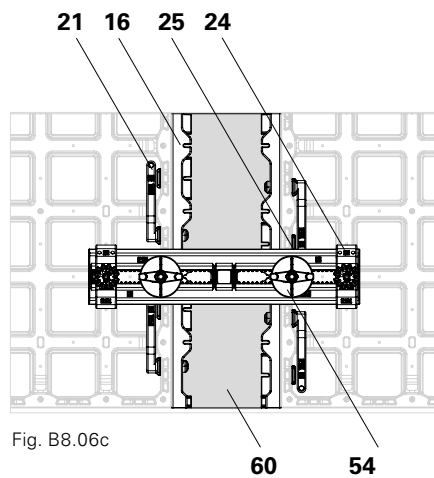

Fig. B8.06c

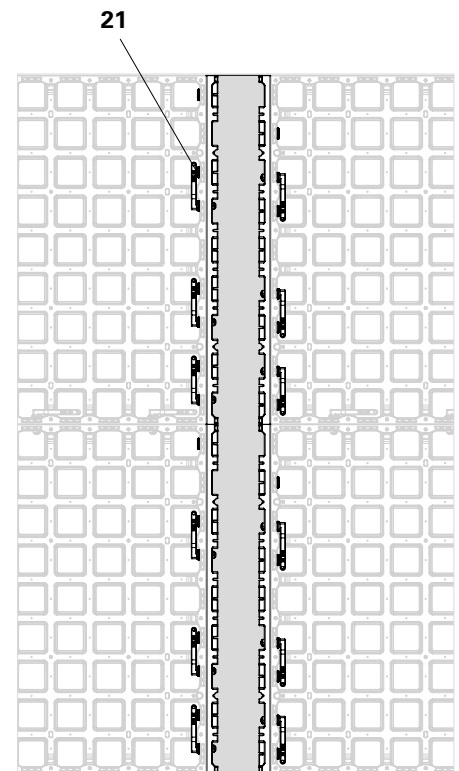

Fig. B8.06a

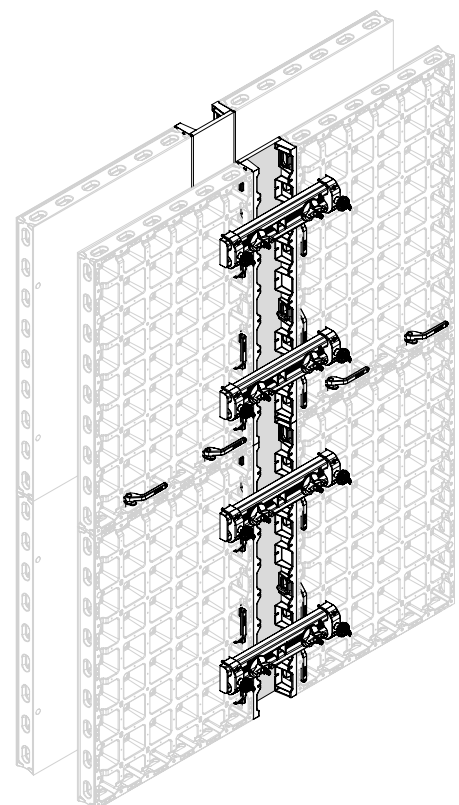

Fig. B8.06

## Stopend formwork

With DP 135 x 90 panel (11.4) and DMP 135 x 75 multi panel (12.2).

For wall thicknesses  $\leq 35$  cm.

### Required components:

11.4	DP 135 x 90 panel	4x
12.2	DMP 135 x 75 multi panel	2x
21	DUO coupler	16x*
23.1	DUO corner connector	8x
23.2	DUO corner tie	8x
29	DUO 135 chamfer strip	4x
54	DW 15 wingnut counterplate	8x



Connect the stopend formwork to the following formwork using 4 DUO couplers (21) for each DP 135 x 90 panel (11.4). (Fig. B9.01b)

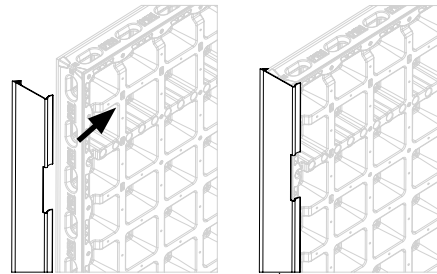

Fig. B9.01

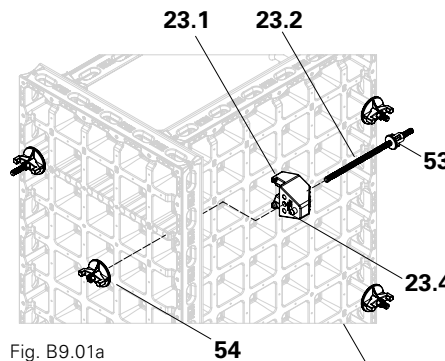

Fig. B9.01a

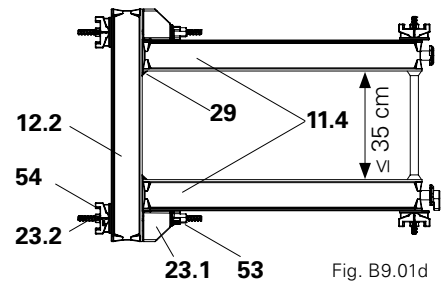

Fig. B9.01d

### Installation

1. Attach a DUO 135 chamfer strip (29) to both DP 135 x 90 panels. (Fig. B9.01)
2. Disassemble the DUO corner connector (23), screw the cam nut (53) onto the corner tie.
3. Position the DMP 75 multi panel (12.2) in front of both DP 135 x 90 panels (11.4) at a right angle.
4. Insert the DUO corner connector (23.1) into the frame strut of the panel.
5. Insert the steel pin (23.4) of the DUO 62 corner connector (23.1) into the appropriate tie point of the multi panel. (Fig. B9.01a)
6. Push the DUO corner tie (23.2) through the DUO corner connector (23.1) and the DMP 135 x 75 multi panel (12.2).
7. Tighten with the wingnut counterplate (54) from the rear side of the multi panel by hand or with the DUO cleaning device (8). (Fig. B9.01e)
8. Repeat steps 4 - 7 on the other side of the stopend formwork.

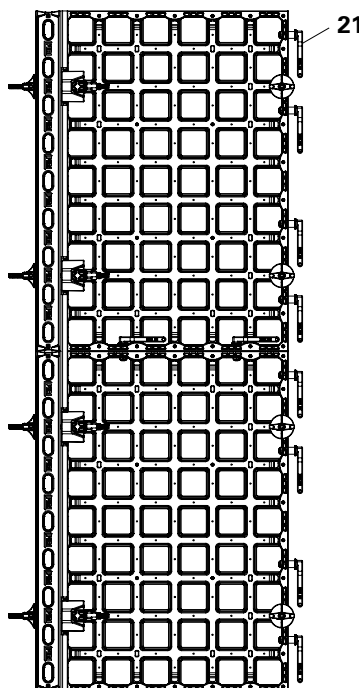

Fig. B9.01b

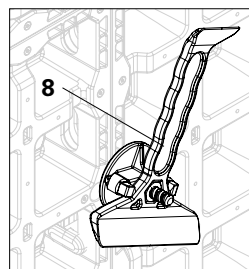

Fig. B9.01e

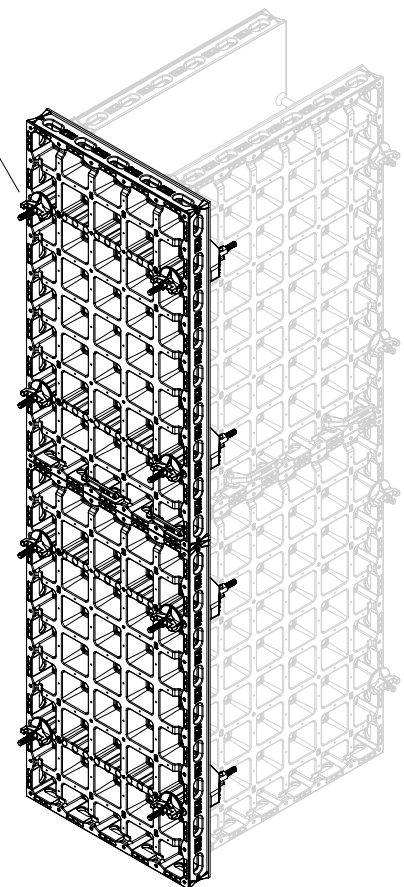

Fig. B9.01c

\* Not taking into account horizontal connections.

## Stopend formwork

With square timber, filler plate and DMP 135 x 75 multi panel.

For wall thicknesses up to  $\leq 40$  cm.

### Required components:

<b>12.2</b> DMP 135 x 75 multi panel	4x
<b>21</b> DUO coupler	16x**
<b>23.2</b> DUO corner tie	8x
<b>25</b> DUO 62 compensation waler	4x
<b>54</b> DW 15 wingnut counterplate	8x
<b>90</b> 270 x* filler plate	1x
<b>91</b> Square timber	2x

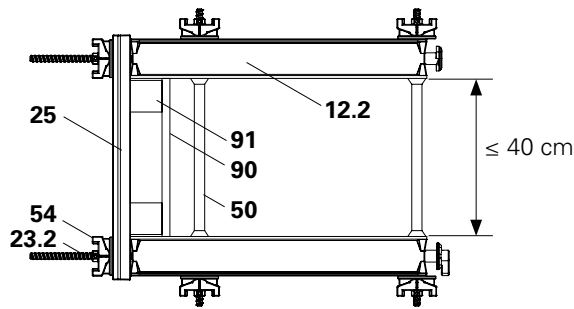

Fig. B9.02



Mount the DUO 62 compensation waler (**25**) in the connector pocket directly under the tie points. (Fig. B9.02a + Fig. B9.02b)

Connect the stopend formwork to the following formwork using 4 DUO couplers (**21a to 21d**) for each DP panel. (Fig. B9.02a)

### Installation

1. Mount tie (**50**) but do not tighten, see section B2, Tie system. Observe the thickness of the stopend formwork for positioning the tie.
2. Cut the filler plate (**90**) to suit the wall thickness.
3. Install the filler plate and two square timbers (**91**).
4. Insert the DUO corner tie (**23.2**) through the connector pocket (**10.2**) of the DP panel directly below the tie point. Screw on the DW 15 cam nut (**53**).
5. Position the DUO 62 compensation waler (**25**) on the DUO corner tie (**23.2**), and tighten with the wingnut counterplate (**54**) by hand or using the DUO cleaning device (**8**). (Fig. B9.02c)
6. Tighten the ties.  
→ Stopend formwork is mounted.

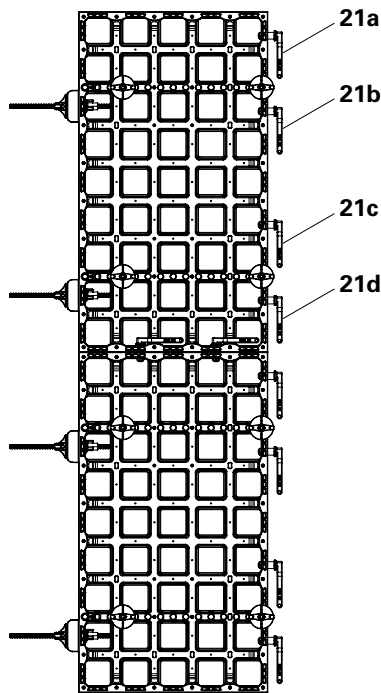

Fig. B9.02a

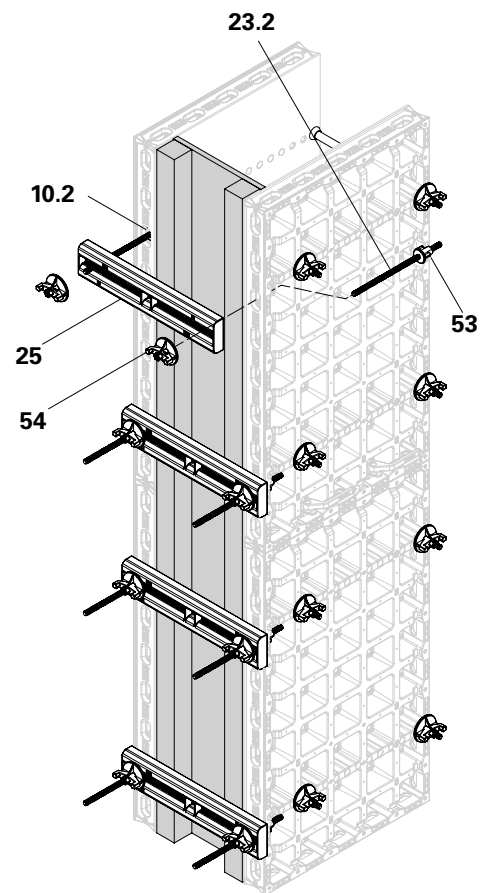

Fig. B9.02b

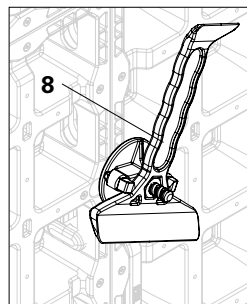

Fig. B9.02c

\* Dependent on wall thickness.

\*\* Not taking into account horizontal connections.

## Stopend formwork

With square timber, filler plate and DP 135 x 90 panel.

For wall thicknesses  $\leq 40$  cm.

### Required components:

11.4	DP 135 x 90 panel	4x
21	DUO coupler	16x**
23.2	DUO corner tie	8x
25	DUO 62 compensation waler	4x
54	DW 15 wingnut counterplate	8x
90	270 x* filler plate	1x
91	Square timber	2x
91a	Spacers for timber	2x

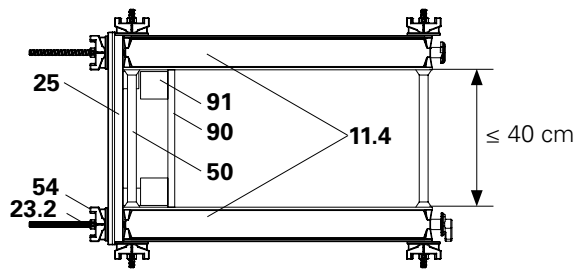

Fig. B9.03



Mount the DUO 62 compensation waler (25) in the connector pocket (10.2) 2 levels below the tie points (Fig. B9.03a + Fig. B9.03b). Connect the stopend formwork to the following formwork using 4 DUO couplers (21a to 21d) for each panel. (Fig. B9.03a)

### Installation

1. Cut the filler plate (90) to suit the wall thickness.
  2. Install the filler plate and two square timbers (91). (Fig. B9.03)
  3. Mount the ties (50), see section B2, Tie system.
  4. Insert the DUO corner tie (23.1) through the connector pocket of the panel 2 levels below the tie point. Screw on the cam nut.
  5. Position the DUO 62 compensation waler (25) on the DUO corner tie (23.1), and tighten with the wingnut counterplate (54) by hand or using the DUO cleaning device (8). (Fig. B9.03c)
  6. Fill space between the square timber and DUO 62 compensation waler (25) with wooden spacers (91a). (Fig. B9.03b)
- Stopend formwork is mounted.

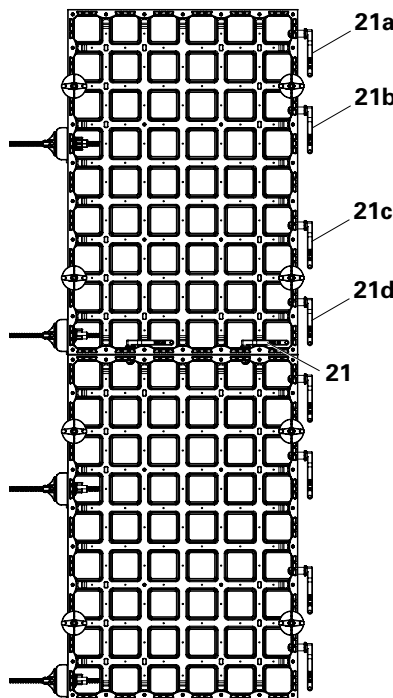

Fig. B9.03a

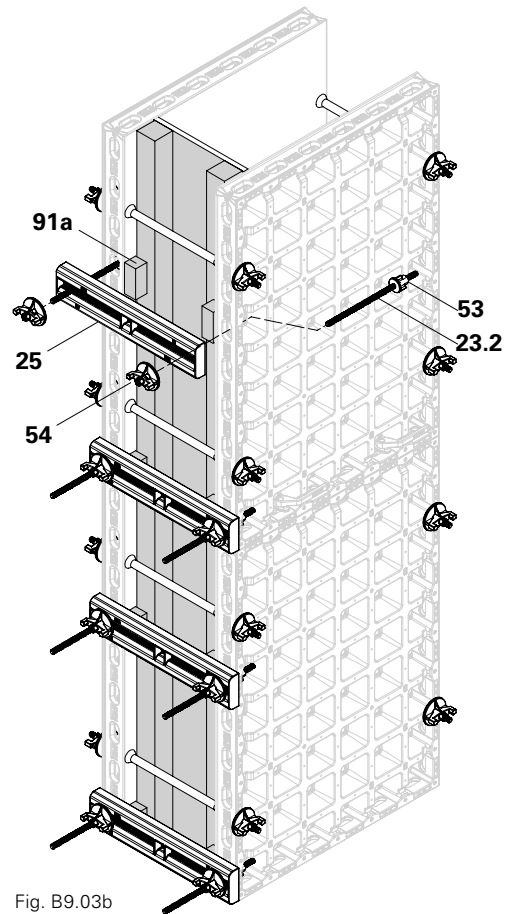

Fig. B9.03b

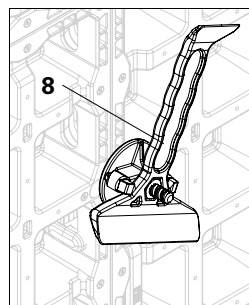

Fig. B9.03c

\* Dependent on wall thickness.

\*\* Not taking into account horizontal connections.

## Stopend formwork

With panels and wall thickness compensation.

For wall thicknesses  $\leq 40$  cm, only in combination with DMP multi panel (12) for the primary formwork and closing formwork.



Connect the stopend formwork to the following formwork using 4 DUO couplers for each panel.

Combine the DP 135 x 15 panel, DP 135 x 30 panel, the DWC 135 wall thickness compensator and DC 135 x 10 corner post as required.

(Fig. B9.04 – Fig. B9.04b)

Use the DUO coupler (21) and DUO coupling tie (23.2) for connection purposes.

## Required components:

11.1	DP 135 x 15 panel	x*
11.2	DP 135 x 30 panel	x*
12	DMP multi panel	4x
13	Wall thickness compensator	x*
20	DC 135 x 10 corner post	x*
21	DUO coupler	16x**
23.2	DUO corner tie	8x
25	DUO 62 compensation waler	4x
54	DW 15 wingnut counterplate	8x

\* Dependent on wall thickness.

\*\* Not taking into account horizontal connections.

### Wall thickness 25 cm:

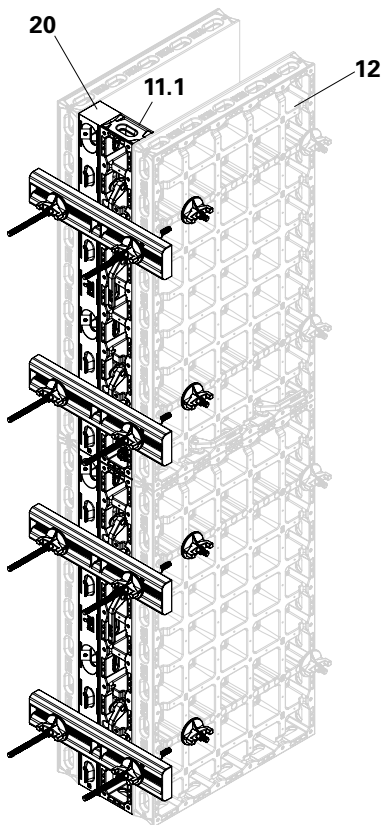

Fig. B9.04

### Wall thickness 30 cm:

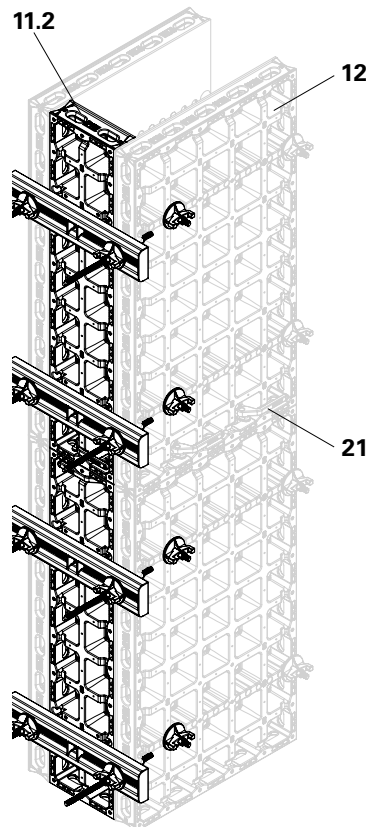

Fig. B9.04a

### Wall thickness $\leq 40$ cm:

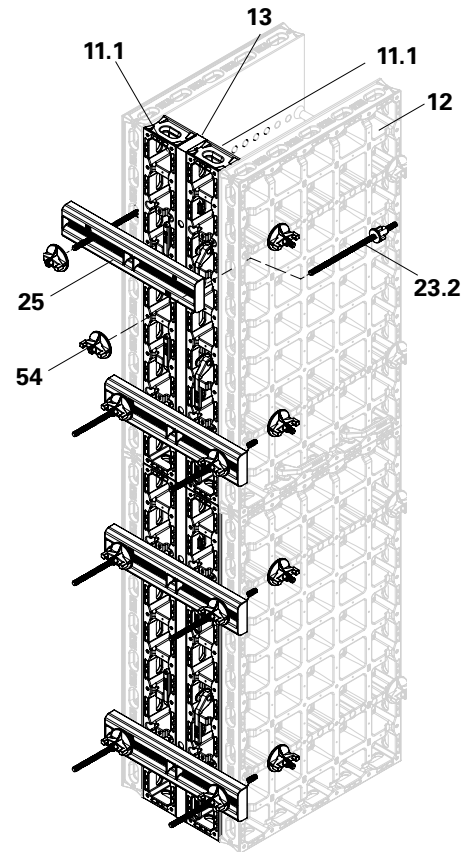

Fig. B9.04b

## Height offset

DUO panels enable height compensation up to 2.5 cm within the clearance of the connector pocket (**10.2**).  
(Fig. B10.01 + Fig. B10.01a)

The next height compensation is from 12.5 cm to 17.5 cm and then every 15 cm.

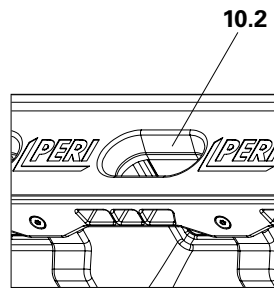

Fig. B10.01a

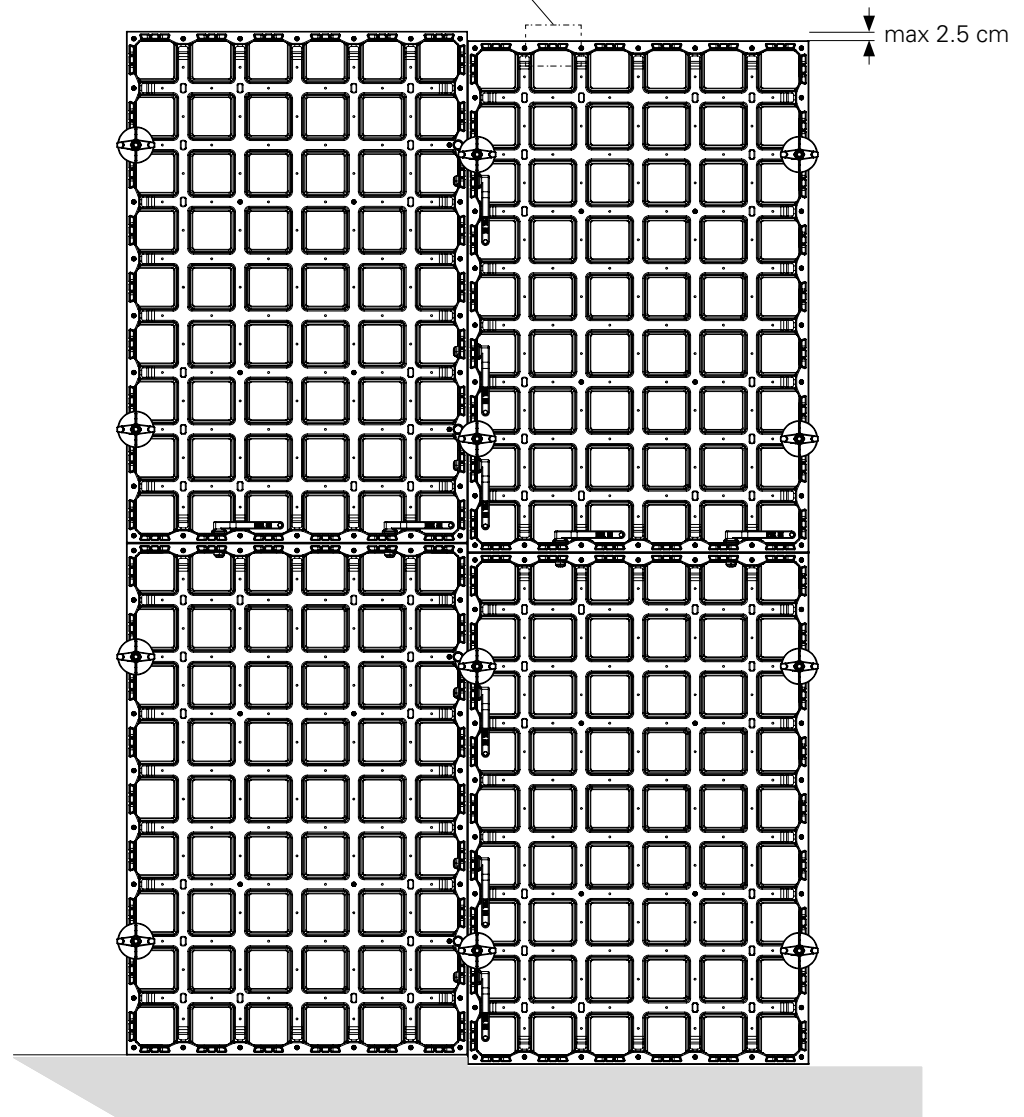

Fig. B10.01

## Height extensions using DP 135 panels



- Take into account the permissible load-bearing capacity of the DUO crane eye of 200 kg and the crane capacity!
- Follow the Instructions for Use for the DUO crane eye!
- Heights over 4.05 m require the DUO 62 compensation waler (**25**) to be installed in every horizontal panel joint.

### Connecting panels

Connect DP panels with DUO couplers (**21**), see section A3 Panel connections.

### Installation

- Lay out square timbers or planking as a base.
- The assembly area must be even!
- Pre-assemble extension units in a horizontal position with the formlining facing downwards.

#### Up to H = 3.60 m

Assemble the third panel level in a horizontal direction. (Fig. B10.02)  
Panels from 15 cm to 90 cm can be used.

#### Up to H = 4.05 m

Assemble the third panel level in a vertical direction. (Fig. B10.03)

#### Up to H = 4.95 m

Assemble the fourth panel level in a horizontal direction. (Fig. B10.04)  
Install the DUO 62 compensation waler (**25**) in every horizontal panel joint. (Fig. B10.04a)

#### Up to H = 5.40 m

Assemble the fourth panel level in a vertical direction. (Fig. B10.05)  
Install the DUO 62 compensation waler (**25**) in every horizontal panel joint. (Fig. B10.04a)

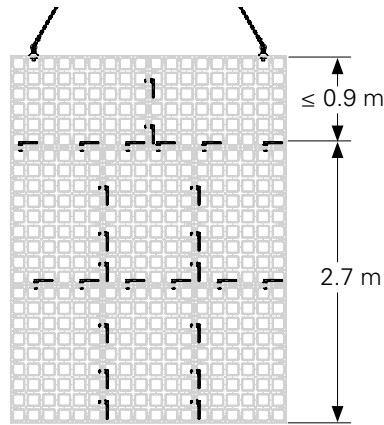

Fig. B10.02

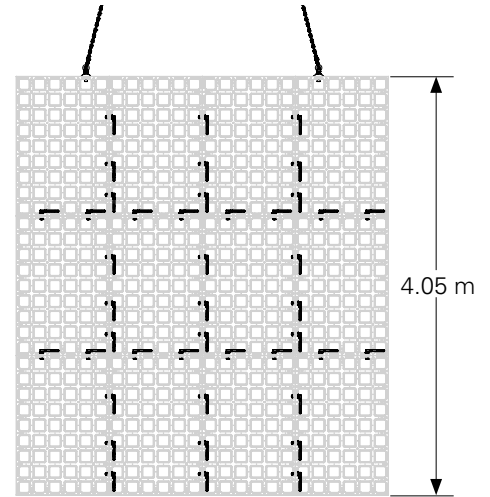

Fig. B10.03

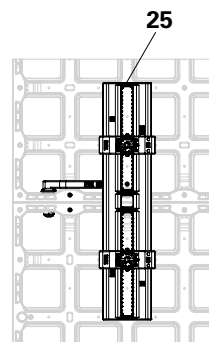

Fig. B10.04a

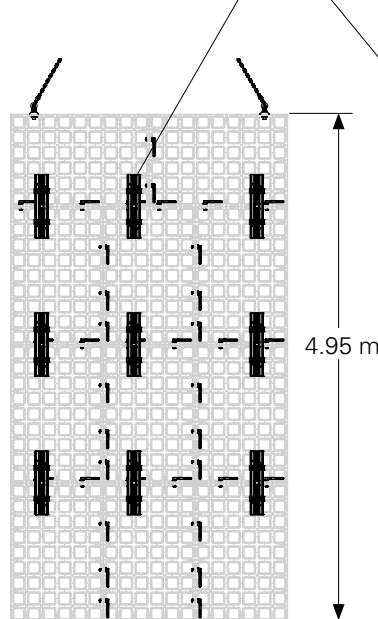

Fig. B10.04

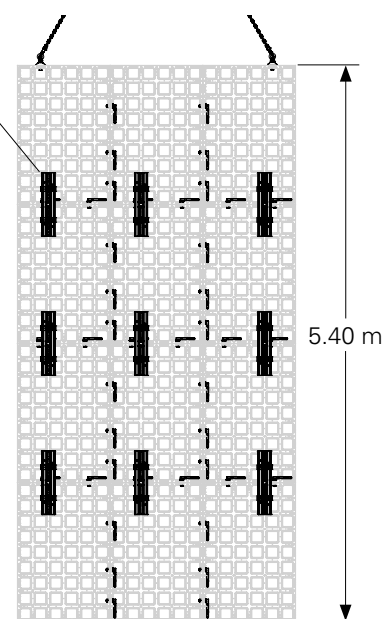

Fig. B10.05

## Height extensions using DP 60 panels

By combining DP 60 panels with DP 135 panels, heights of 2.55 m, 2.70 m and 3.30 m can be realised.  
For tie positions, see (Fig. B10.06).

## Height extensions with DFP filler panels

### Caution

The component may end up being subjected to excessive loads!  
The component could collapse!

- ⇒ Always install filler panels as the top element on DP 135 or 60 panels.
- ⇒ Attaching lifting gear to the filler panel is not permitted.
- ⇒ Install filler panels only when formwork panels are in position and secured.
- ⇒ Mount no more than 3 rows of DFP filler panels (**0.45 m**)!

By combining the DP 135 panel, DP 60 panel and DFP filler panel, heights of 2.55 m up to 3.30 m can be realised in 15 cm increments.  
(Fig. B10.08)

### Installation

1. Mount the DFP filler panel (**17.7**) at the top of the standard panels using the DUO coupler (**21**). (Fig. B10.07a)
2. Connect the DFP filler panels (**17.7**) beneath each other using DUO couplers (**21**).
3. For required number of DUO couplers, see section A3 Panel connections.
4. Install the DUO coupling tie (**22**). For tie positions, see (Fig. B10.08).

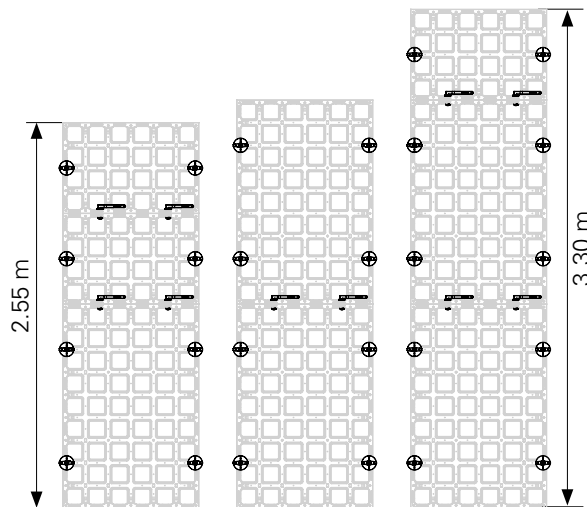

Fig. B10.06

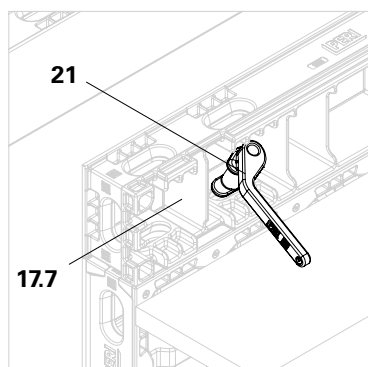

Fig. B10.07a

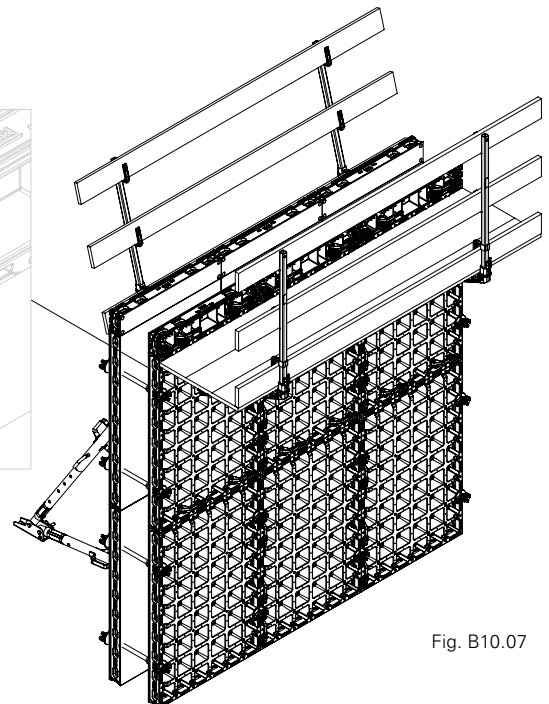

Fig. B10.07

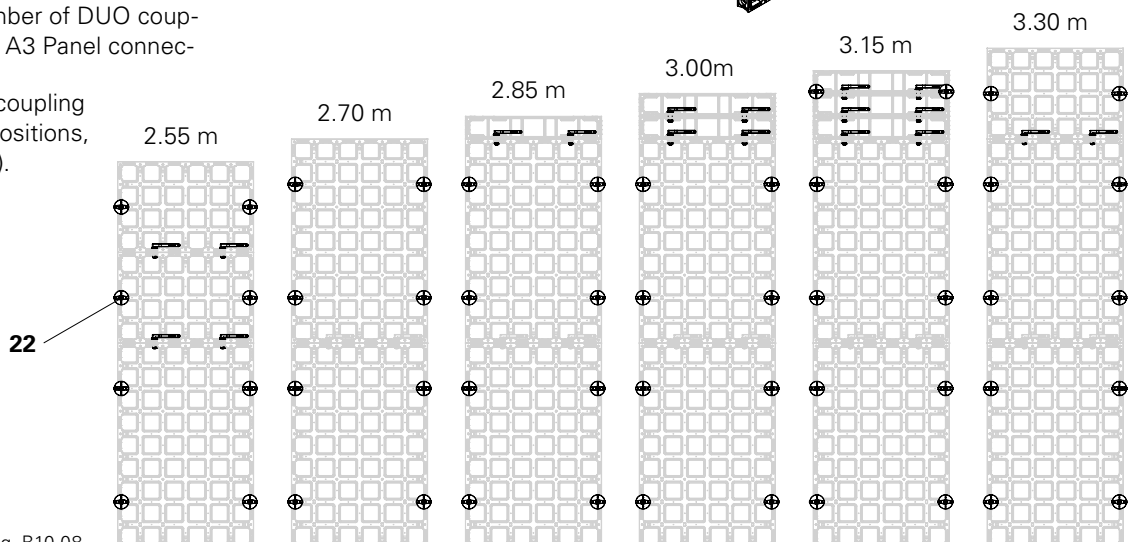

Fig. B10.08

## Tie positions for DFP filler panels

### 1 row

DUO coupler (21) not required on vertical joints.

Ties not required in the height extensions.

(Fig. B10.09 + Fig. B10.09a)

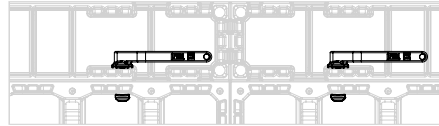

Fig. B10.09a

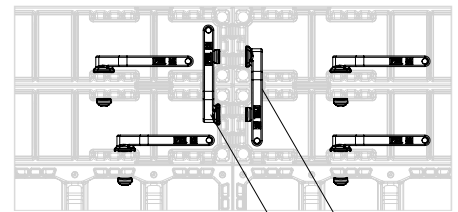

Fig. B10.10a

### 2 rows

Swivel the DUO coupler (21) on the vertical joint of the bottom row (21a) upwards, swivel downwards on the top row (21b).

Ties not required in the height extensions.

(Fig. B10.10 + Fig. B10.10a)

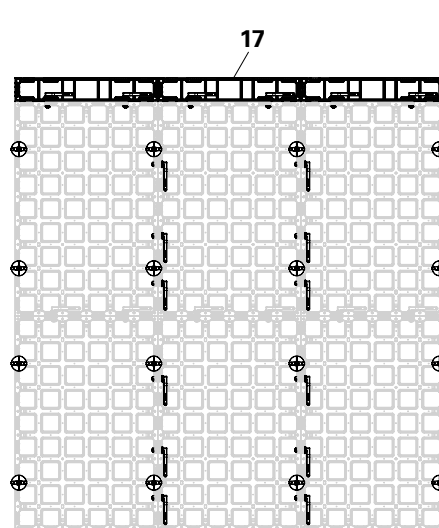

Fig. B10.09

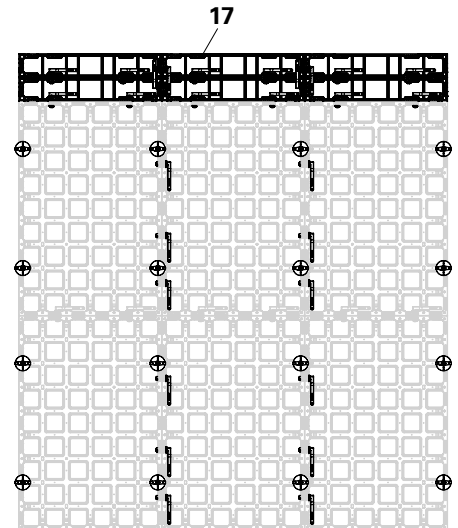

Fig. B10.10

### 3 rows

Swivel the DUO coupler (21) on the vertical joint of the bottom row (21a) upwards, swivel downwards on the middle and top rows (21b).

Mount the tie with the DW 15 wingnut counterplate (54) on the middle DFP filler panel up to the top panel joints.

(Fig. B10.11 + Fig. B10.11a)

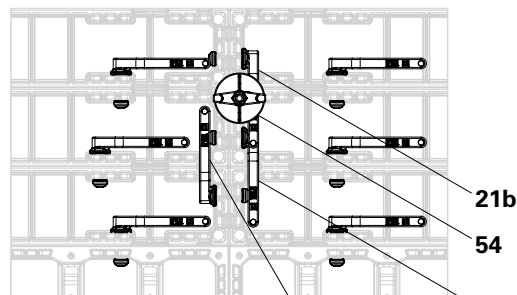

Fig. B10.11a

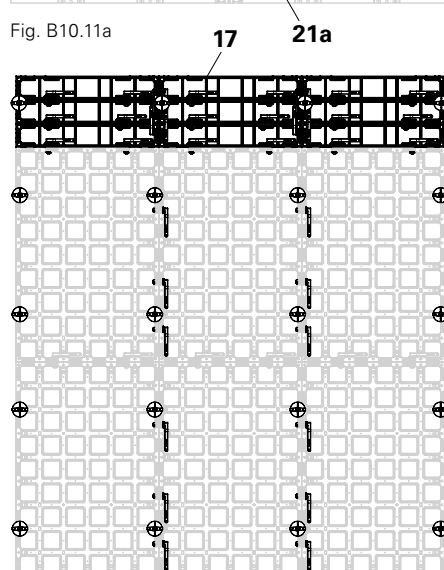

Fig. B10.11

## Extensions with DES extension support

Use DES extension support (40) with filler plate (90) for extensions up to max. 30 cm.

For general information, see section A4 Additional accessories, DES extension support.



- Connect every DES extension support (40) to the DP 135 panel, DP 60 panel or DFP filler panel using DUO couplers (21).
- Maximum height of the filler plates (90): 0.30 m.
- Maximum width of influence: 0.60 m. (Fig. B10.12b)

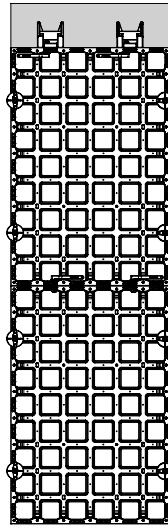

Fig. B10.12

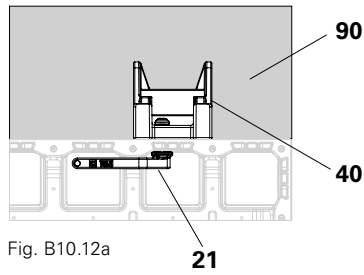

Fig. B10.12a

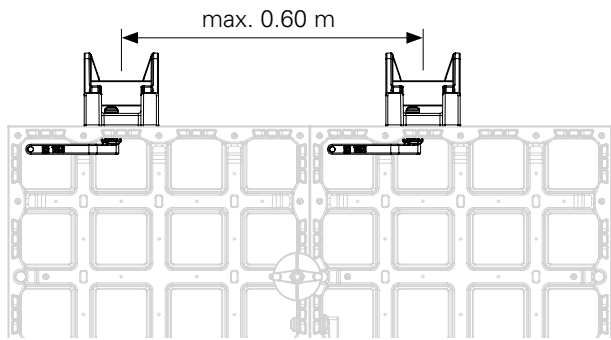

Fig. B10.12b

## Tie positions

If the DES extension support is mounted on the DP 135 or DP 60 panel, the guidelines in section B10 Height extensions with panel DP 60 shall apply.

When mounting the DES extension support (40) on a DFP filler panel (17), additional ties including DW 15 wing-nut counterplates (54) are to be installed.

Mount ties in the top DFP filler panel (17) on the joint to the DES extension support.

(Fig. B10.13)

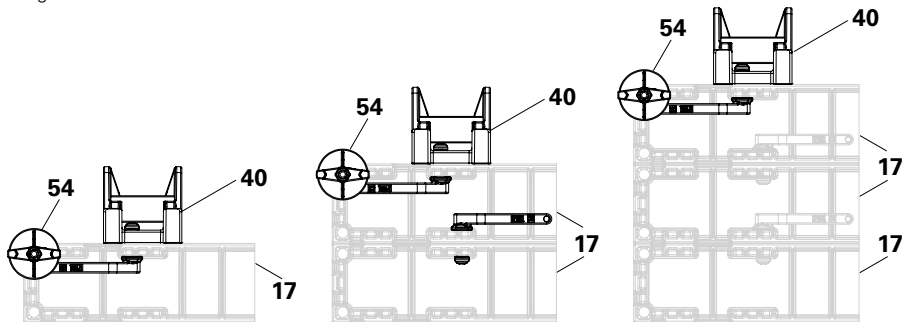

Fig. B10.13

## 90° corners with DES extension support

At internal and external corners, mount the DES extension support (40) as close to the corner as possible.

(Fig. B10.14 + Fig. B10.14a)

Fig. B10.14

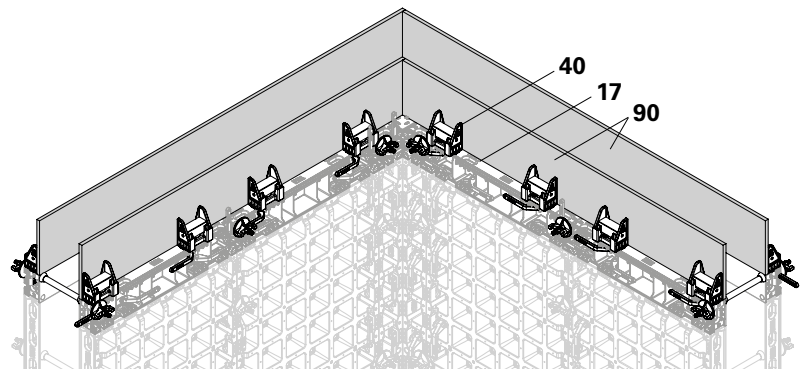
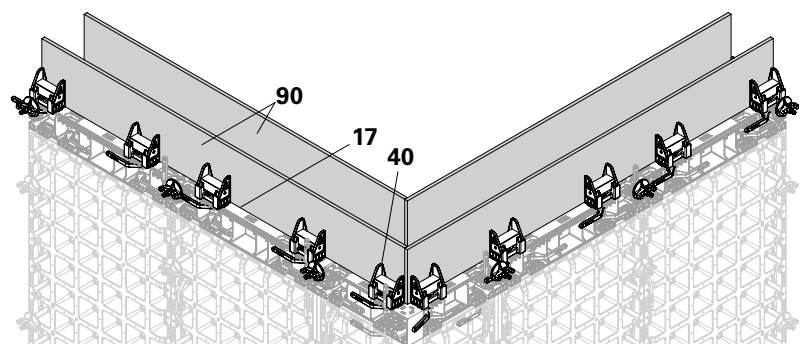

Fig. B10.14a



## Foundation formwork with DP panels

All DUO DP panels (**10**) are suitable for forming foundations.

For foundations with DP 135 x 90 (**11.4**), DP 135 x 60 and DP 135 x 30 panels, use cam nut DW 15 (**53**) in order to prevent the nut and the base from overlapping at the bottom tie point. (Fig. B11.01 + Fig. B11.01a)

If panels are used in the horizontal direction, then only 2 DUO couplers (**21**) are required for connecting the short panel joints. (Fig. B11.01b)

### Components:

- 10** DP 135 x 90 panel
- 21** DUO coupler
- 53** Cam nut DW 15

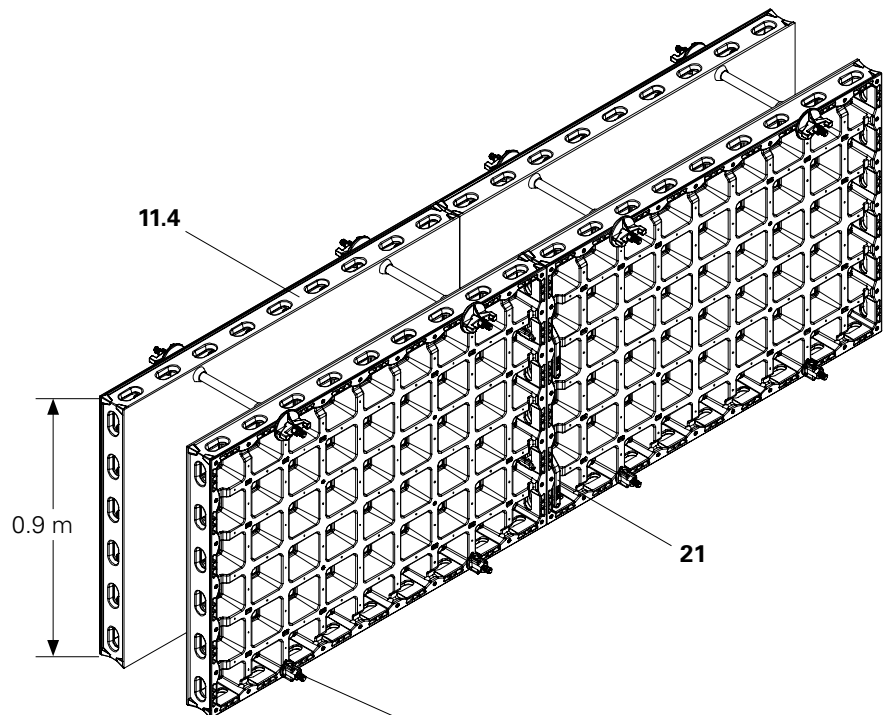

Fig. B11.01

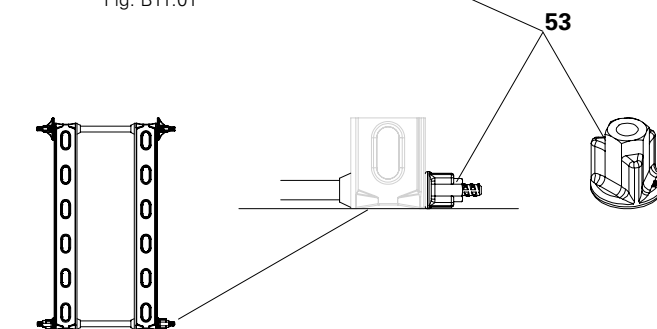

Fig. B11.01a

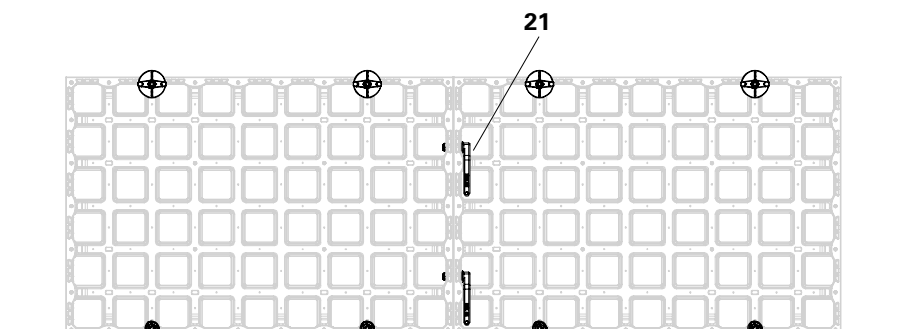

Fig. B11.01b

## Foundation formwork with DMP multi panels

The DW 15 wingnut counterplate (**54**) can be used for foundations with DMP 75 multi panels (**12.2**) and DMP 45 multi panels.

For this purpose, select the second tie point from the bottom to avoid overlapping of the DW 15 wingnut counterplate (**54**) and the base.

(Fig. B11.02 + Fig. B11.02a)

If panels are used in the horizontal direction, then only 2 DUO couplers (**21**) are required for connecting the short panel joints.

(Fig. B11.02b)

### Components:

- 12.2** DMP 75 multi panel
- 21** DUO coupler
- 54** DW 15 wingnut counterplate

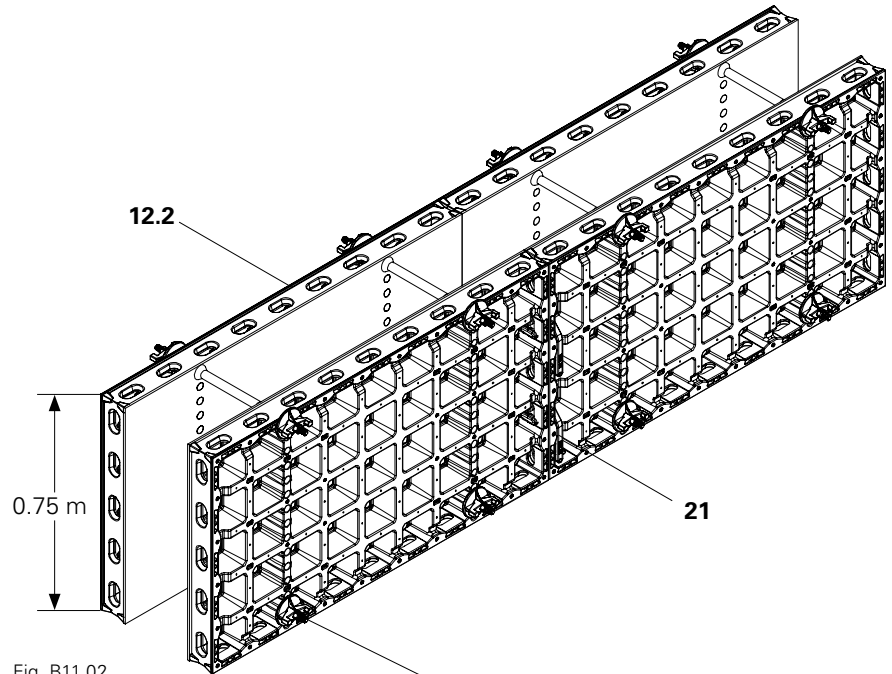

Fig. B11.02

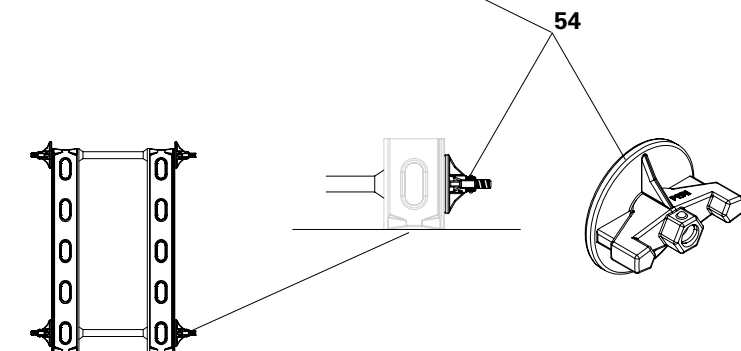

Fig. B11.02a

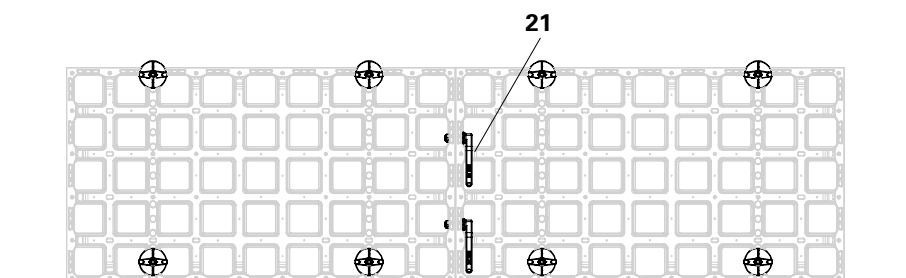

Fig. B11.02b

## Foundation formwork with DP 60 panels

DUO DP 60 panels (**18**) are also suitable for forming foundations.

The anchoring takes place on the middle of the panel with one row of tie rods. Install square timber (**91**) that matches the wall thickness on top of the formwork so that the formwork does not tilt inwards.

(Fig. B11.03 + Fig. B11.03a)



The maximum width of influence of the square timber is 1.80 m.

If DP panels are used in the horizontal direction, then only 2 DUO couplers (**21**) are required for connecting the short panel joints.

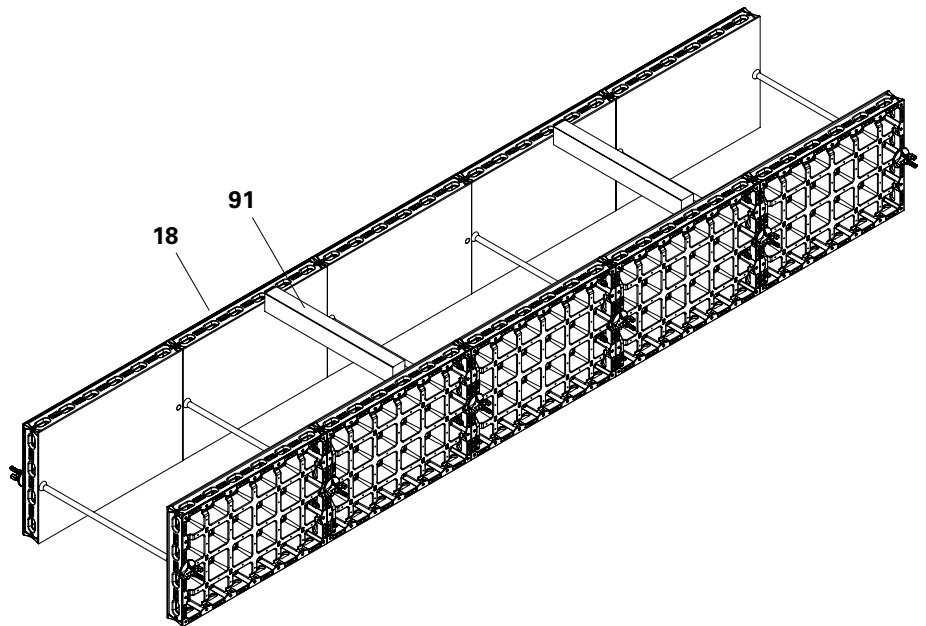

Fig. B11.03

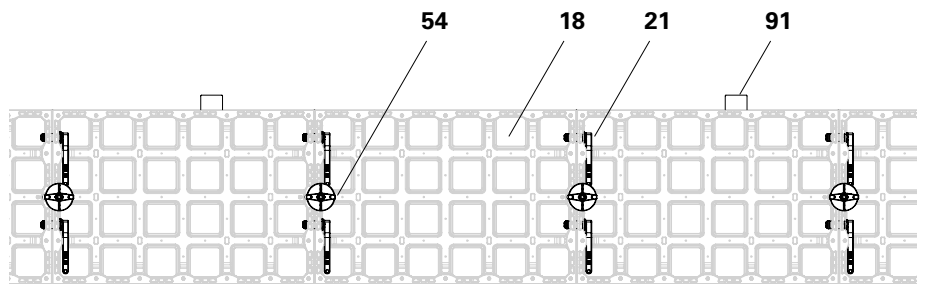

Fig. B11.03a

The combinations for foundations with 90° corners, T-junctions or intersections are established as described in sections B5 Corners, B6 T-junctions, wall connections and B7 Wall offsets. (Fig. B11.04)

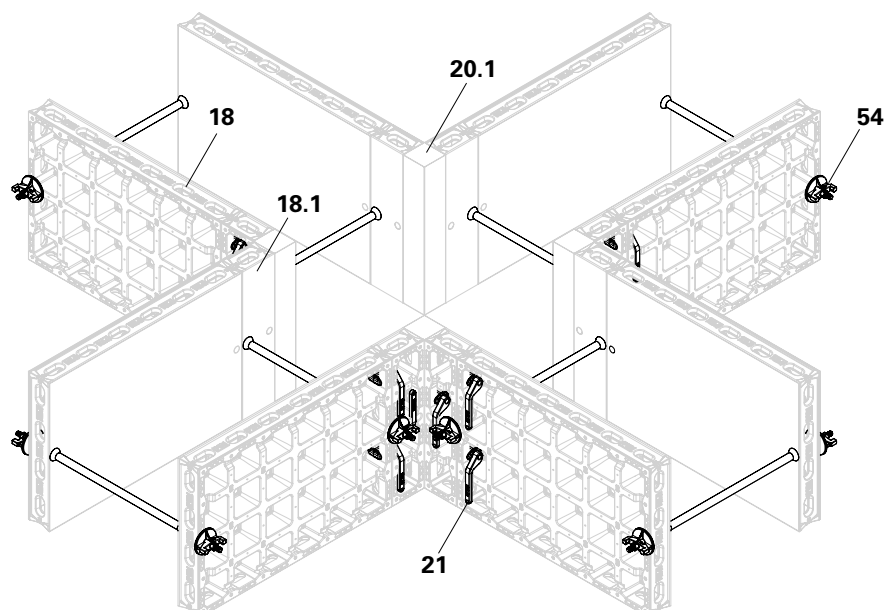

Fig. B11.04

### Components:

- 18** DP 60 x 90 panel
- 18.1** DP 60 x 15 panel
- 20.1** DC 60 corner post
- 21** DUO coupler
- 54** DW 15 wingnut counterplate
- 91** Square timber

## Foundation formwork with DUO frame holder

For foundation formwork with horizontal DP 135 x 90 panels (11.4), the top row of tie rods can be moved to the top side of the formwork with the DUO frame holder (41). As a result, the number of tie holes through the foundations is halved.



The maximum width of influence of the top tie points is 1.35 m.  
The maximum height of formwork is 90 cm.

## DUO frame holder with DP panel

### Installation

1. Attach the hooks (41.1) of the DUO frame holder (41) to the frame profile of the panel.  
(Fig. B11.05 + Fig. B11.05a)
2. Insert the tie rod (50) through the frame holder.  
(Fig. B11.06)
3. Tighten the tie rod with the DW 15 wingnut counterplate (54).

For the bottom tie points, use the DW 15 cam nut (53) to prevent the nut and the base from overlapping at the bottom tie point.  
(Fig. B11.06 + Fig. B11.06a)

## DUO frame holder with DP multi panel

The DW 15 wingnut counterplate (54) can be used for foundations with DMP 75 multi panels (12.2) and DMP 45 multi panels.

For this purpose, select the second tie point from the bottom to avoid overlapping of the DW 15 wingnut counterplate (54) and the base.

### Components:

- |      |                            |
|------|----------------------------|
| 11.4 | DP 135 x 90 panel          |
| 41   | DUO frame holder           |
| 50   | DW 15 tie rod              |
| 53   | Cam nut DW 15              |
| 54   | DW 15 wingnut counterplate |

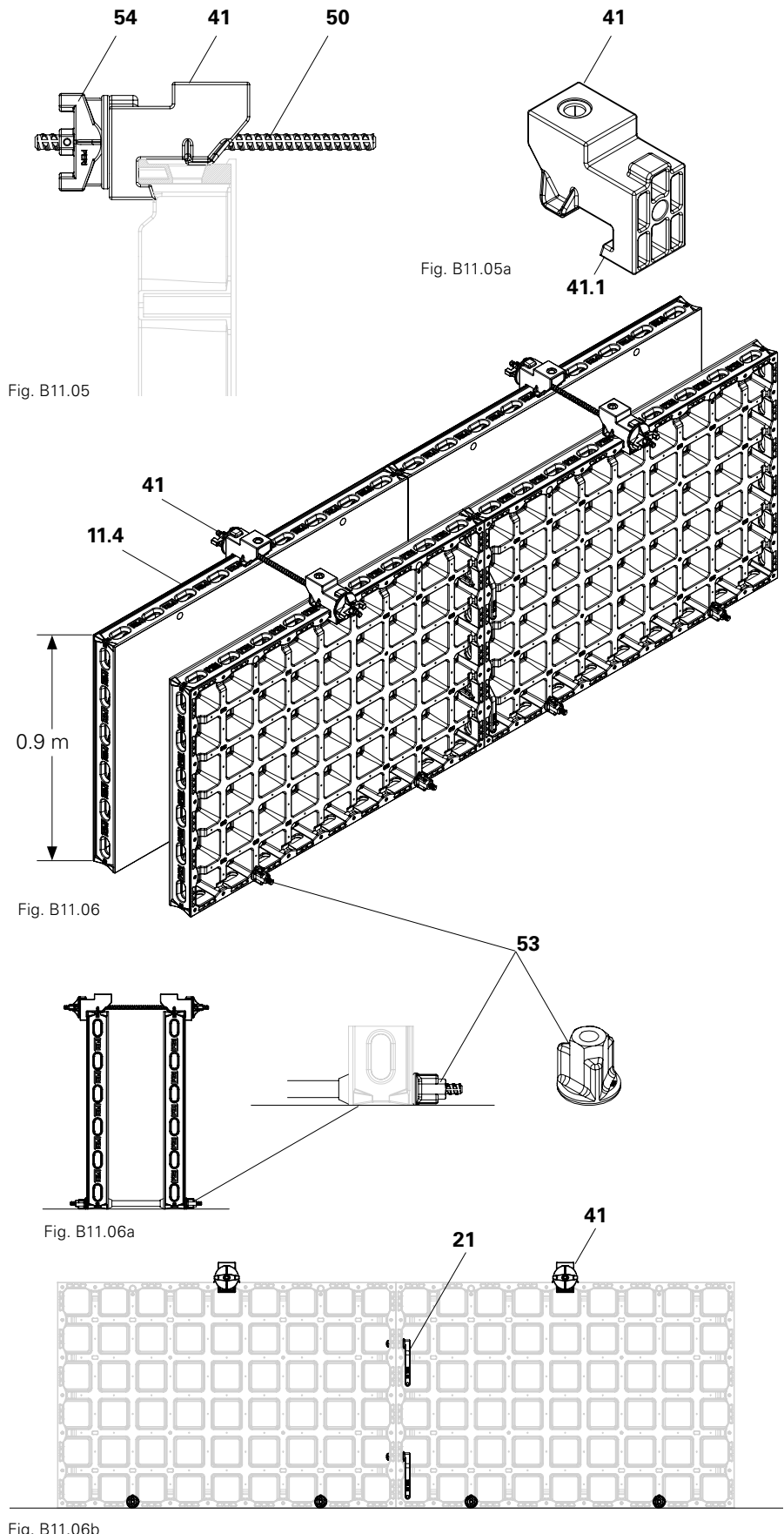

Fig. B11.06b

## Foundation formwork with DUO foundation tie clamp

If lower anchor ties are not present in strip foundations and individual foundations up to 90 cm in height, the DUO foundation tie clamp (**84**) is used together with a perforated foundation tie (**84.1**).

(Fig. B11.07)

### Required perforated foundation tie length

Foundation width + 50 cm

### Installation

1. Connect and secure the foundation tie clamp (**84**) and DUO brace connector (**27**) with a rod and cotter pin (**27.4**).  
(Fig. B11.08)
2. Position DP panels (**10**) on the perforated foundation tie (**84.1**). The perforated foundation ties should be positioned underneath the tie holes.  
(Fig. B11.09)
3. Insert the DUO foundation tie clamp (**84**) into the perforated foundation tie (**84.1**).
4. Fit the DUO brace connector (**27**) and foundation tie clamp (**84**) to a bottom connection point in the DP panel with a cross tie bolt.
5. Turn the cross tie bolt by 90°.
6. Tighten the foundation tie clamp (**84**) with the DW 15 grip (**27.2**).  
(Fig. B11.10)
7. Each panel requires min. 2 foundation ties at a max. distance of 75 cm.

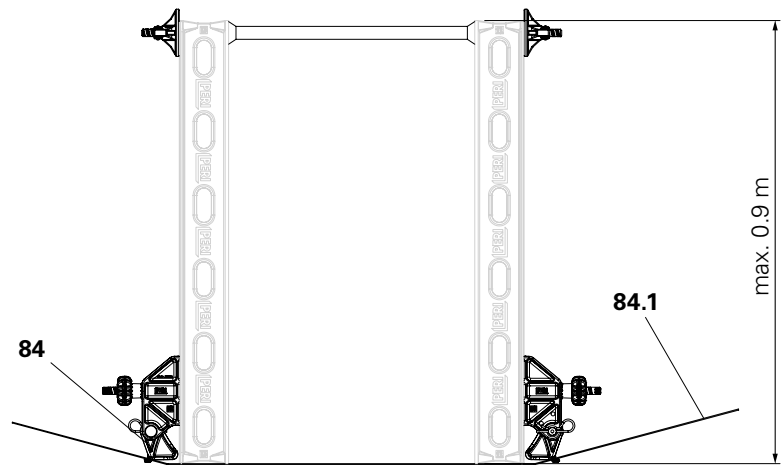

Fig. B11.07

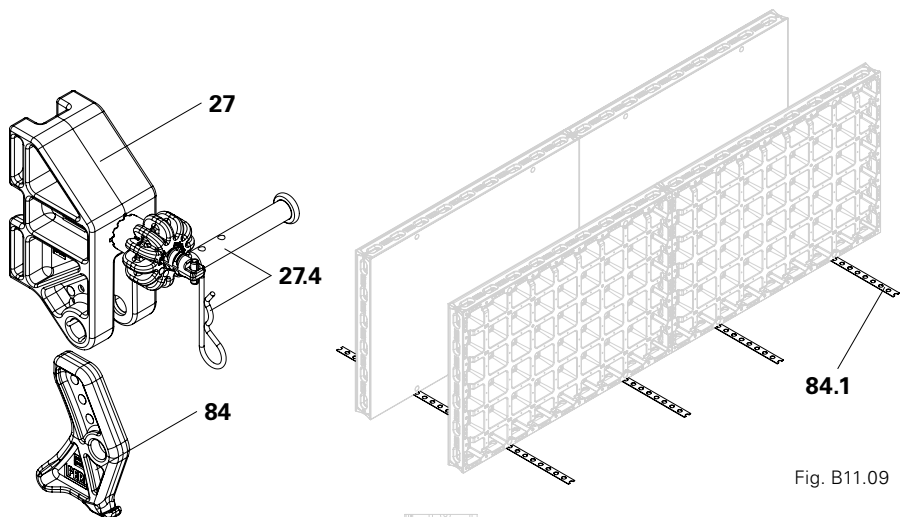

Fig. B11.09

Fig. B11.08

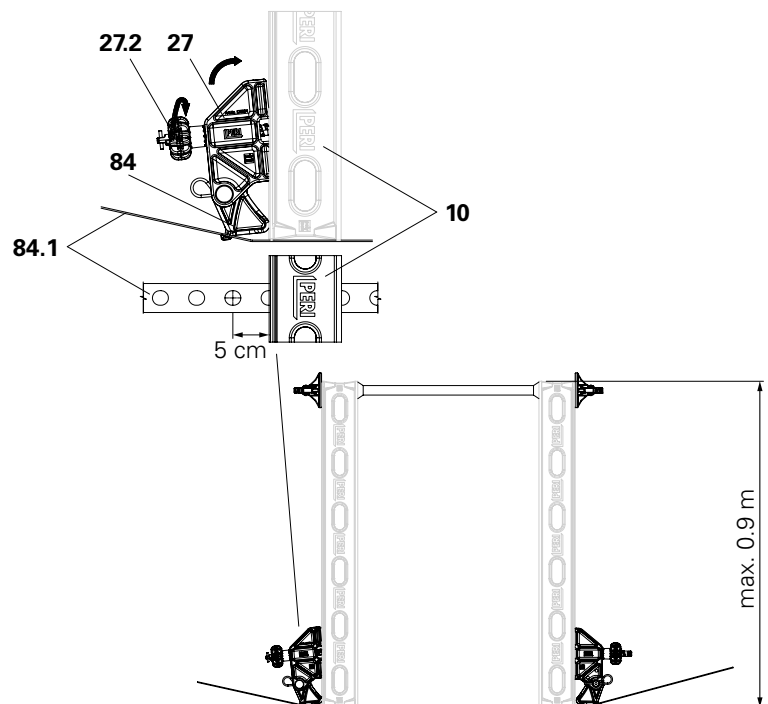
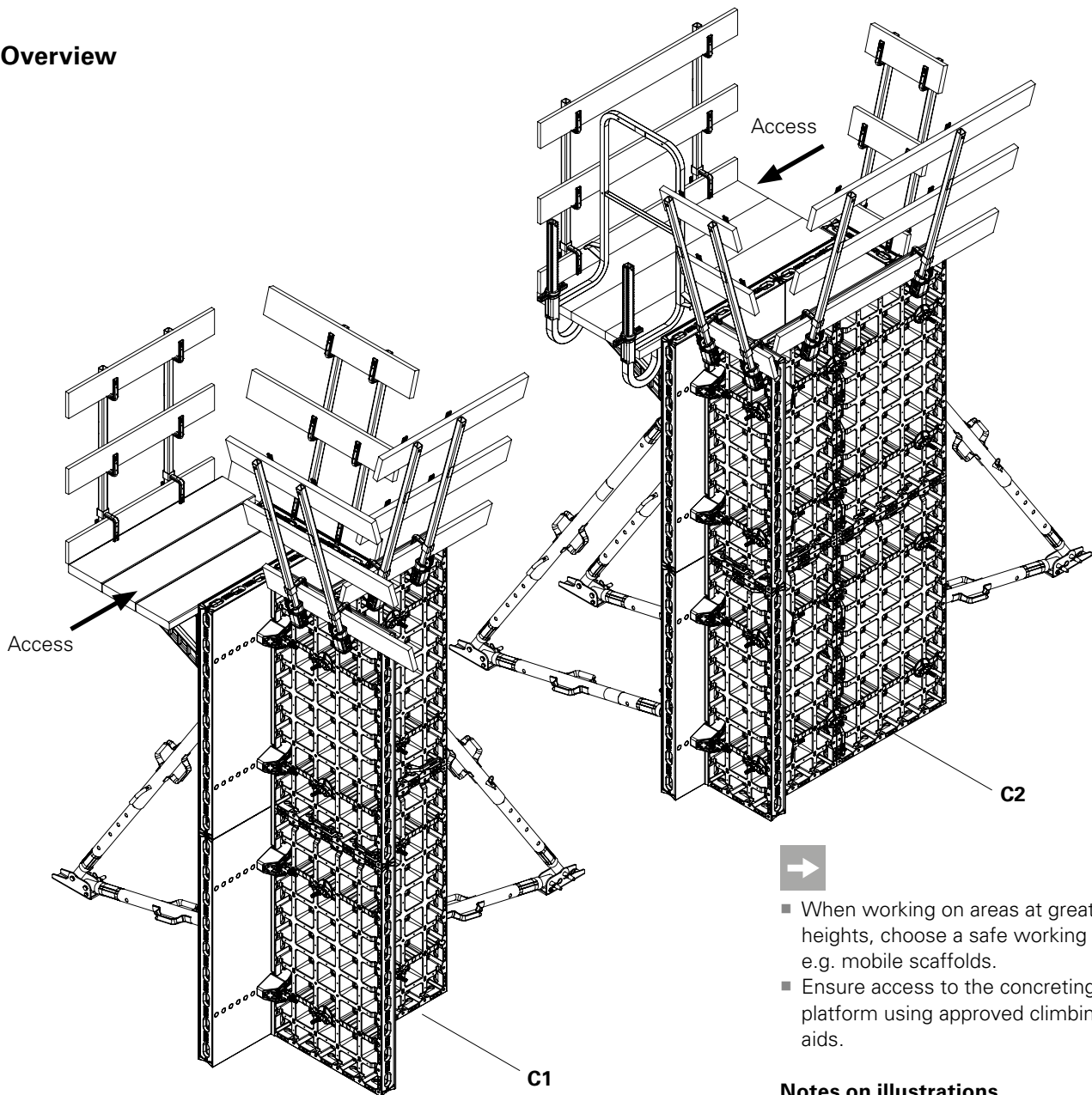

Fig. B11.10

## Overview



- When working on areas at great heights, choose a safe working area, e.g. mobile scaffolds.
- Ensure access to the concreting platform using approved climbing aids.

### Notes on illustrations

The structures presented in these Instructions for Assembly and Use are shown in the form of examples with only one component size. Instructions on vertical applications refer to a construction height of 2.70 m. They are valid for all component sizes included in the standard configuration.

To facilitate understanding, detailed illustrations are sometimes incomplete. The safety installations which have possibly not been shown in these detailed illustrations must nevertheless be available.

### Column formwork

C1	Column formwork	106
	– using DUO DMP multi panels	107
	Assembly without a crane	108
	Striking without a crane	110
	Striking with a crane	111
	DUO steel waler connectors	112
C2	Shear walls	114
	Cross-sections	114
	DUO attachment parts and couplers	116
	Striking	117

## Column formwork with DUO DMP multi panels

Column cross-sections from 15 cm to 55 cm can be formed in 5 cm increments with DMP 135 x 75 and/or DMP 135 x 45 multi panels combined with DUO corner connectors and DUO 135 chamfer strips.

(Fig. C1.01 + Fig. C1.02)

**Column formwork up to 25 cm**  
with DMP 135 x 45 multi panel.

### Required components:

<b>12.1</b> DMP 135 x 45 multi panel	8x
<b>21</b> DUO coupler	8x
<b>23</b> DUO corner connector	16x
<b>23.2</b> DUO corner tie	16x
<b>29</b> DUO 135 chamfer strip	8x
<b>54</b> DW 15 wingnut counterplate	16x

(Fig. C1.01 + Fig. C1.01a)

**Column formwork up to 55 cm**  
with DMP 135 x 75 multi panel.

### Required components:

<b>12.2</b> DMP 135 x 75 multi panel	8x
<b>21</b> DUO coupler	8x
<b>23</b> DUO corner connector	16x
<b>23.2</b> DUO corner tie	16x
<b>29</b> DUO 135 chamfer strip	8x
<b>54</b> DW 15 wingnut counterplate	16x

(Fig. C1.02 + Fig. C1.02a)

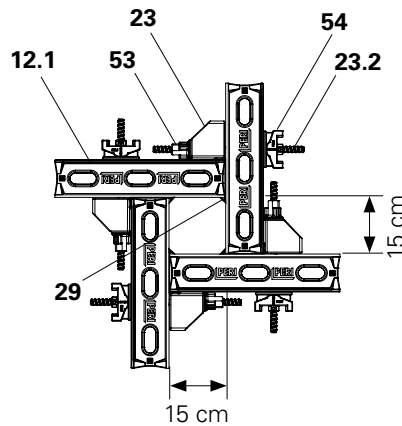

Fig. C1.01

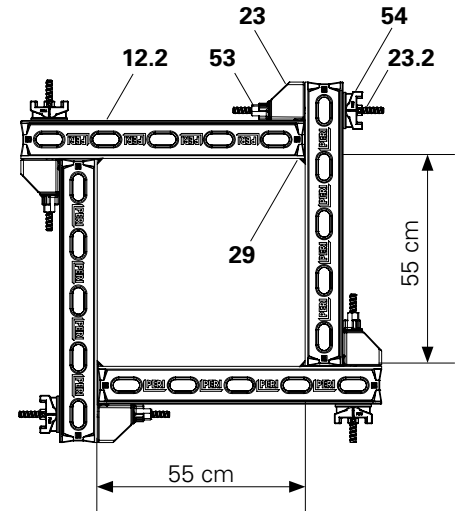

Fig. C1.02

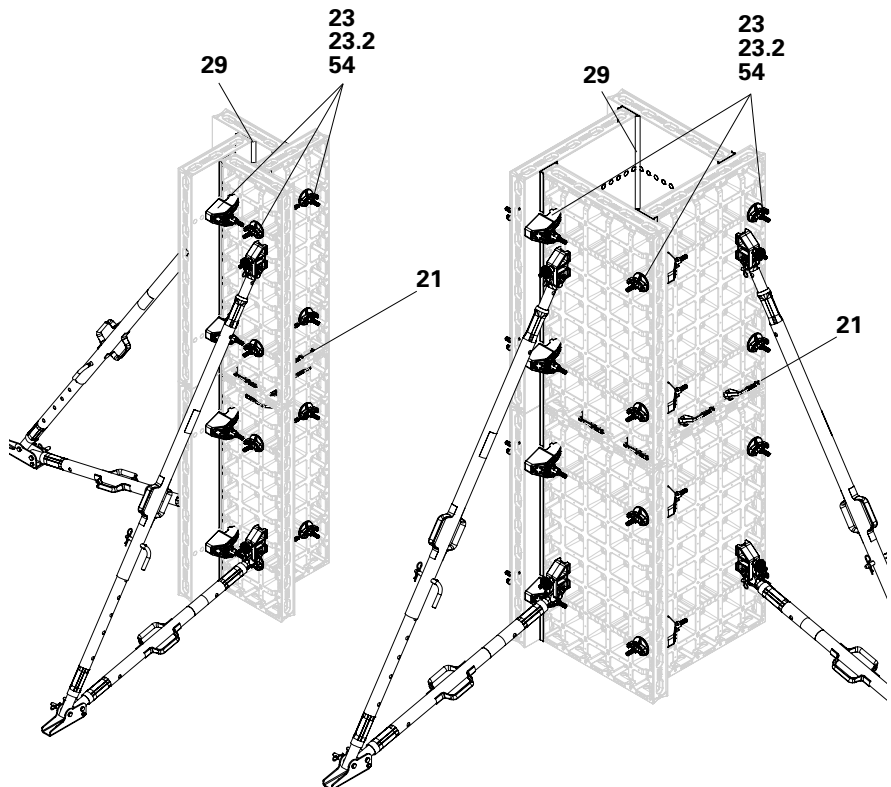

Fig. C1.01a

Fig. C1.02a

## Assembly without a crane



### Caution

Heavy component!

If the component is carried by one person, it may fall down or topple over and cause injuries

- ⇒ Take into account the weight of two connected panels. Have panels transported/carried by two persons.
- ⇒ Secure panels against tilting and wind forces!



When working on areas at great heights, choose a safe working area, e.g. mobile scaffolds, see section D2 Shuttering (Fig. D2.13).

### Preparation

- Lay out square timbers or planking as a base.
- The assembly area must be even!
- Assemble or pre-assemble DP panels horizontally with the formlining facing downwards. For panel connections, see section A3 Panel connections.

### Installation

1. Position the DUO 135 chamfer strips (**29**) on the first panel unit, do not nail the DUO 135 chamfer strips (**29**) down. (Fig. C1.03a)
2. Mount two DUO brace connectors (**27**).
3. Two persons are required to transport the panel unit to the place of operation. (Fig. C1.03)
4. Mount the push-pull prop (**38**) and the kicker brace (**39**) on the pre-assembled DUO brace connectors (**27**). Mount the push-pull prop and kicker brace on the base plate and fix the base plate with anchor bolts. (Fig. C1.04)

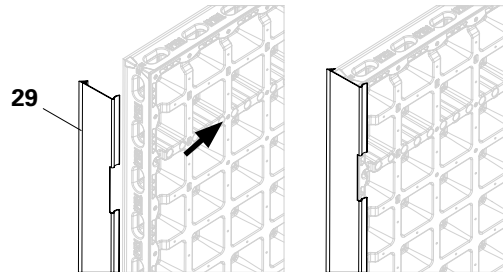

Fig. C1.03a

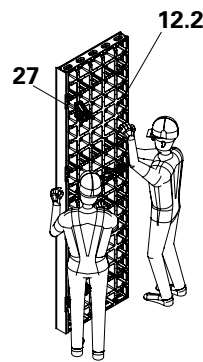

Fig. C1.03

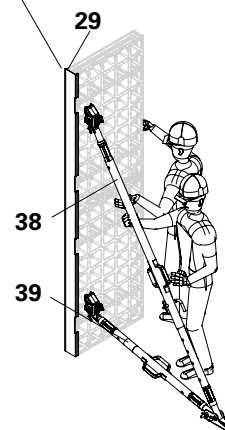

Fig. C1.04

5. Pre-assemble the second panel unit with DUO brace connectors (27) and DUO 135 chamfer strips (29).
6. Connect the second panel unit to the first panel unit using the DUO corner connector (23).  
(Fig. C1.05 + Fig. C1.06)
7. Mount the push-pull prop and kicker brace on the brace connector. Mount the push-pull prop and kicker brace on the base plate and fix the base plate with anchor bolts.  
(Fig. C1.07)
8. In the same way, pre-assemble the third and fourth panel units with DUO 135 chamfer strips (29) and connect with the DUO corner connector (23).  
(Fig. C1.08 + Fig. C1.09)

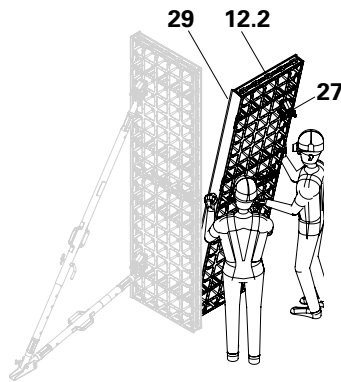

Fig. C1.05

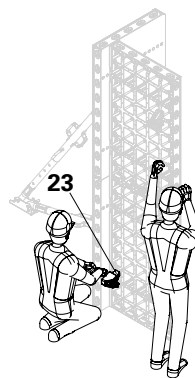

Fig. C1.06

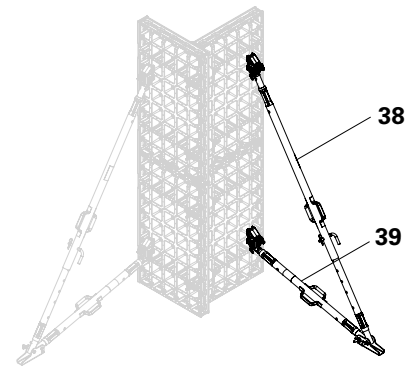

Fig. C1.07

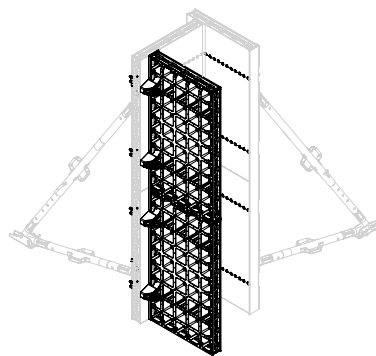

Fig. C1.08

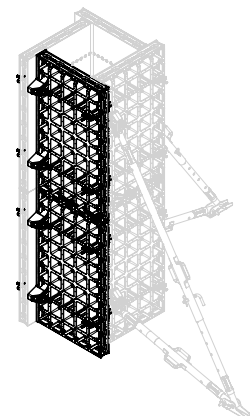

Fig. C1.09

## Safety equipment

Installation

See section B4 Working and concreting platform.

(Fig. C1.10 + Fig. C1.11)

Assembly must be carried out from a safe working position!

## Striking without a crane



### Caution

Heavy components!

Components may fall down while they are being carried or may tilt during striking and cause injuries!

- ⇒ Retract components only when the concrete has sufficiently hardened and the person in charge has given the go-ahead for striking to take place.
- ⇒ Take into account the weight of two connected panels. Have panels transported/carried by two persons.
- ⇒ Secure panels against tilting and wind forces!



When working on areas at great heights, choose a safe working area, e.g. mobile scaffolds, see section D2 Shuttering (Fig. D2.13).

Start the striking process at a panel unit without push-pull props.

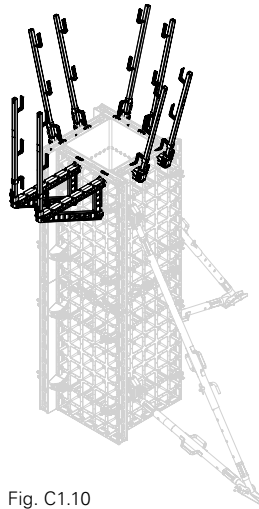

Fig. C1.10

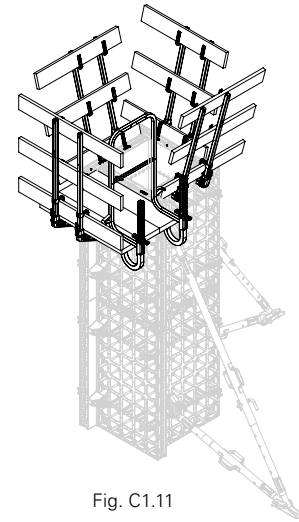

Fig. C1.11

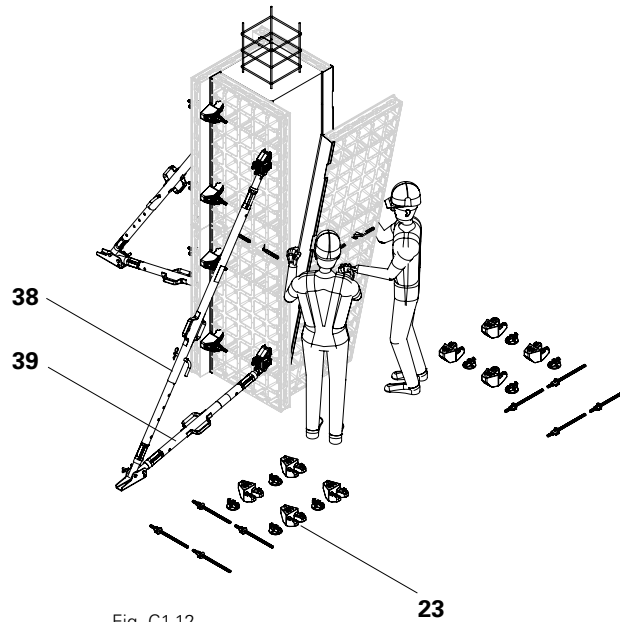

Fig. C1.12

## Dismantling

1. Remove safety devices, e.g. working and concreting scaffolds or protection against lifting.
2. Remove the DUO corner connector (**23**) on both sides of the panel element.
3. Move, clean and transfer the panel unit to the next place of operation.
4. In the same way, move the next panel unit without push-pull props.
5. Dismantle the push-pull props (**38**) and kicker braces (**39**) on the third panel unit.
6. Remove the remaining DUO corner connectors (**23**).
7. Move the panel unit.
8. Loosen the base plates of the last panel unit, remove the push-pull props and kicker braces and move the panel unit. (Fig. C1.12)
9. For panel cleaning instructions, see section E1 Cleaning and maintenance.

## Striking with a crane

Panel units or formwork halves can be moved with the DUO crane eye (28).



### Warning

Heavy suspended components. Components may fall down when they are being carried, may tilt during striking or may fall down when they are being moved by crane and cause serious injuries!

- ⇒ Do not stand under suspended loads!
- ⇒ Concrete strength must be taken into account!
- ⇒ Secure panels against tilting and wind forces!
- ⇒ Take into account the permissible load-bearing capacity of the DUO crane eye of 200 kg and the crane capacity!
- ⇒ Follow the Instructions for Use for the DUO crane eye!



When working on areas at great heights, choose a safe working area, e.g. mobile scaffolds, see section D2 Shuttering (Fig. D2.13).

First move panel units or formwork halves that do not have push-pull props attached.

### Disassembling the formwork halves

1. Attach two-sling lifting gear to the crane eye (28) in the formwork half without push-pull props.
2. Loosen and remove the DUO corner connector (23) from the formwork halves.
3. Release formwork halves from the concrete and relocate them by crane. (Fig. C1.13)
4. Attach the formwork halves with push-pull props to the crane.
5. Loosen the base plates.
6. Relocate the formwork halves with the crane. (Fig. C1.14)

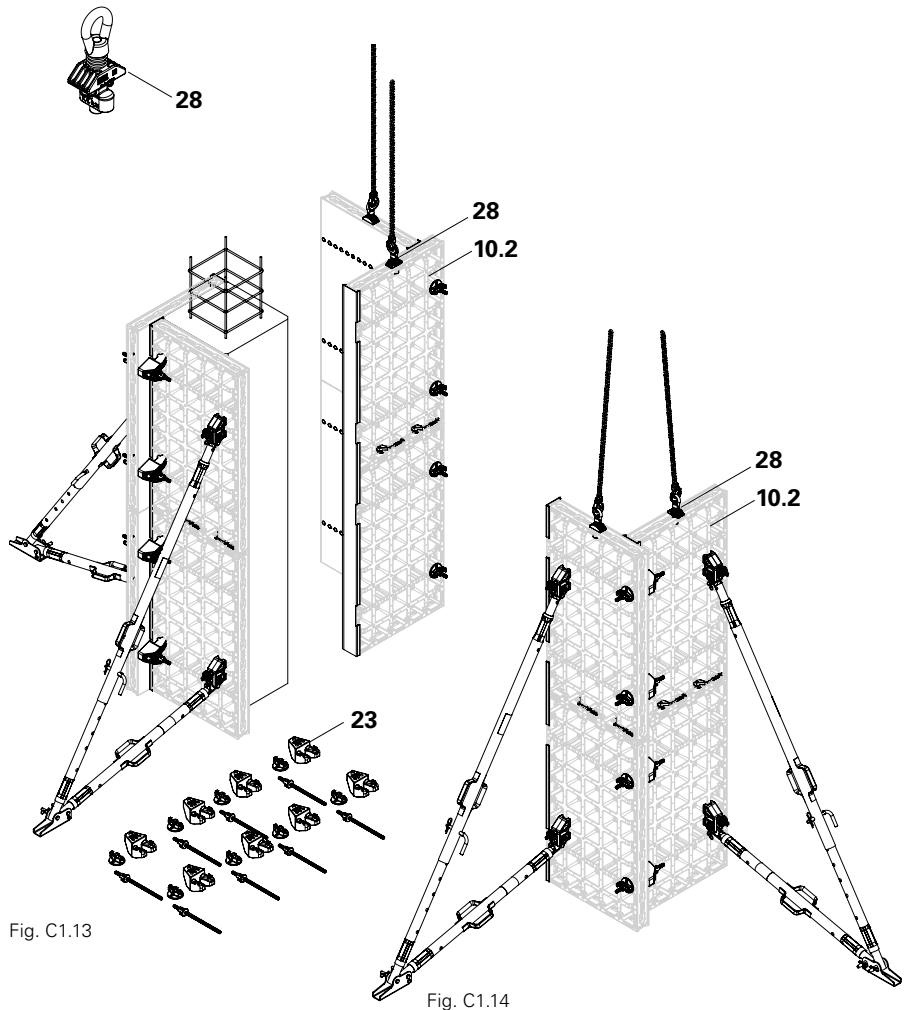

Fig. C1.13

Fig. C1.14

### Disassembling the panel units

1. Attach the crane hook to the DUO crane eye (28) in the panel element without push-pull props. (Fig. C1.15)
2. Loosen and remove the DUO corner connector (23) on both sides of the panel element. (Fig. C1.12)
3. Release the panel element from the concrete and relocate it by crane.
4. To relocate additional panel elements, see Disassembling formwork halves. (Fig. C1.13 + Fig. C1.14)

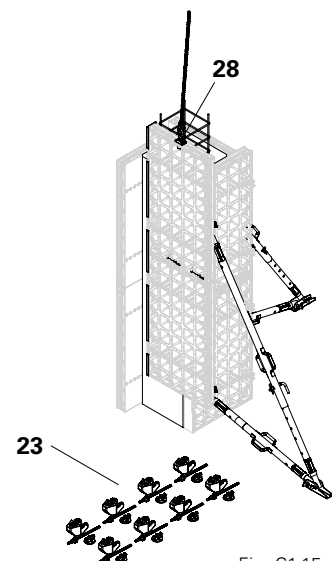

Fig. C1.15

## DUO steel waler connectors

### Maximum width of influence

**0.60 m.**

The DUO steel waler connector (**85**) is used for assembling SRU steel waler universals.

(Fig. C1.16)

### Installation

1. Position the SRU steel waler at the height of the anchor strut of a DP panel (**10**).  
(Fig. C1.17)
2. Fit the DUO steel waler connector (**85**) to a connection point (**10.3**) on the DP panel (**10**) with a cross tie bolt (**85.1**) and turn the cross tie bolt through 90° (**85.1**).
3. Tighten the DUO steel waler connector (**85**) with the DW 15 grip (**85.2**), while ensuring that the connector plate (**85.3**) is positioned correctly.
4. Mount each SRU steel waler with at least two DUO steel waler connectors.  
(Fig. C1.17)
5. Mount at least two SRU steel walers (**88**) for each DP 135 panel using DUO steel waler connectors (**85**).

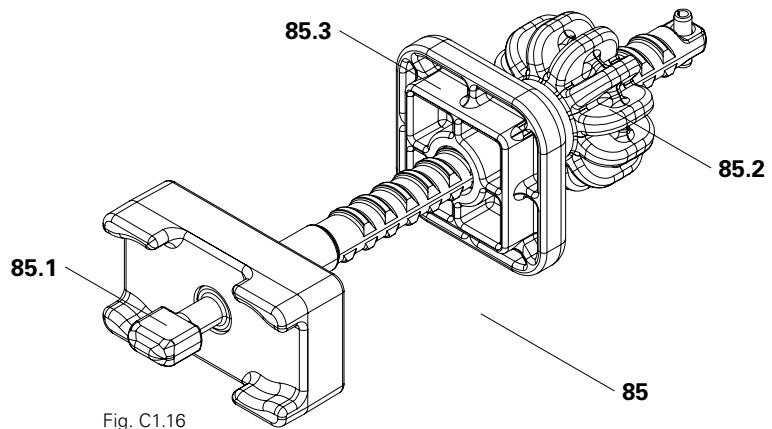

Fig. C1.16

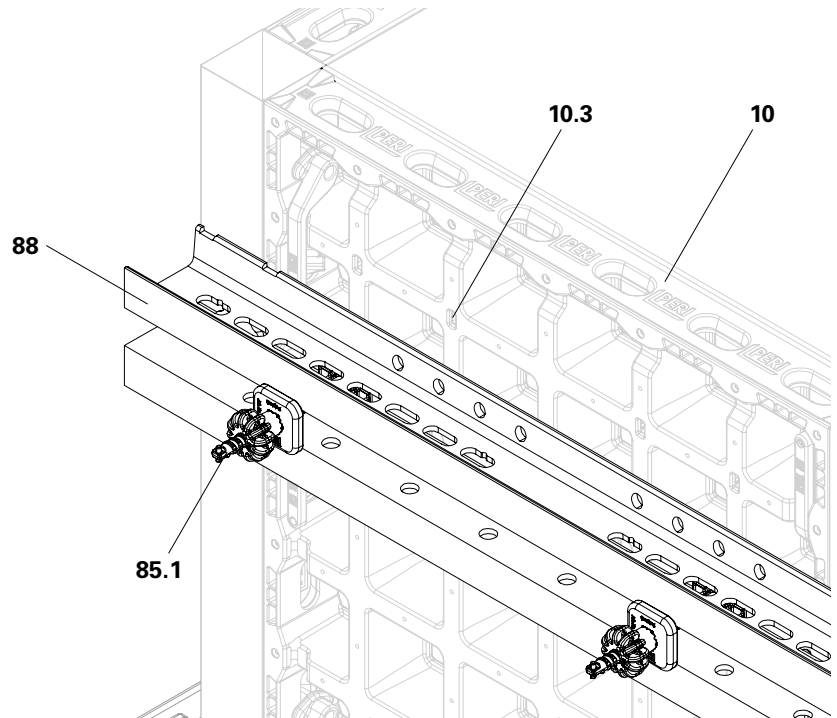

Fig. C1.17

## Usage in the case of DUO column formwork

At all external corners, ensure that two SRU steel walers (**88**) are mounted vertically and in contact with one another. In doing so, use SKZ tie yokes (**46**) and KZ wedges (**47**) to connect the walers. (Fig. C1.18)

### Installation

1. Position the SKZ tie yokes (**46**) with the help of the KZ wedges (**47**) so that they lie flat against the steel waler.
2. Install the tie rod and screw on wingnuts up to the SKZ tie yoke (**46**).
3. Loosen the KZ wedges (**47**).
4. Tighten the wingnuts with the help of the tie rod wrench.
5. Securely fix the KZ wedges (**47**).

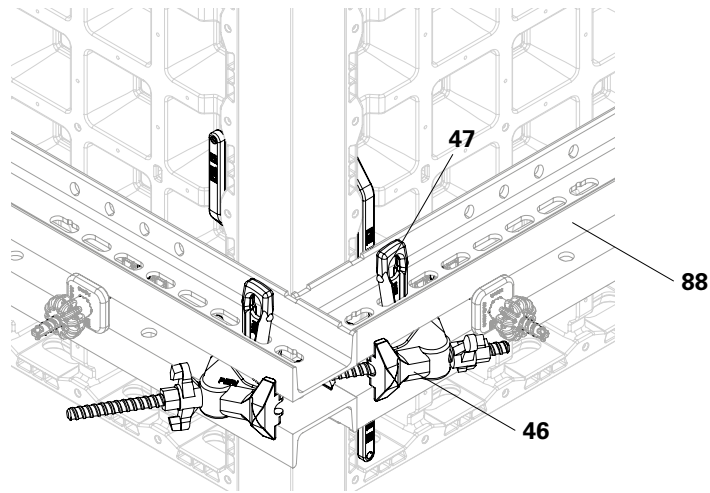

Fig. C1.18

## Cross-sections

Shear walls are anchored centrally.

Cross-sections:

60 x 25 cm - 205 x 55 cm.

### Required components:

<b>12</b>	DMP 135 x 45 – DMP 135 x 75 multi panel	4x
<b>29</b>	DUO 135 chamfer strip	8x
<b>23.1</b>	DUO corner connector	16x
<b>23.2</b>	DUO corner tie	16x
<b>24</b>	DUO tube holder*	0 - 16x
<b>25</b>	DUO 62 compensation waler*	0 - 8x
<b>54</b>	DW 15 wingnut counterplate	16x

(Fig. C2.01)

\*The DUO 62 compensation waler (**25**) must be mounted every time the DW 15 wingnut counterplate (**54**) does not overlap the vertical joint of both panels, see section A3 Panel connections.

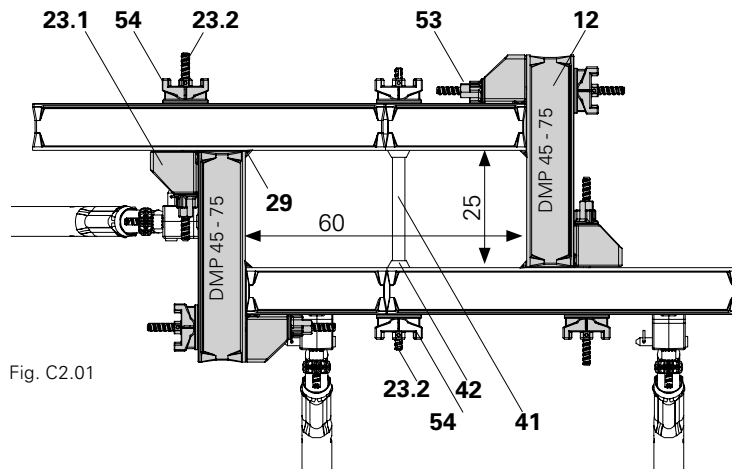

Fig. C2.01

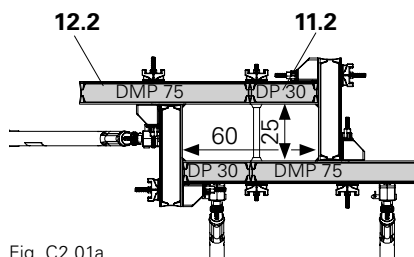

Fig. C2.01a

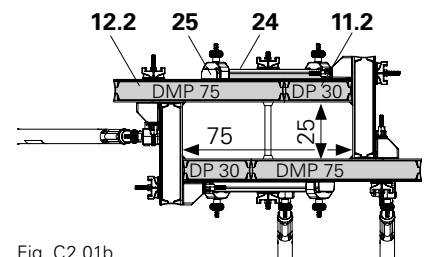

Fig. C2.01b

### L = 60 - 75 cm, with 1 row of ties\*\*

#### Additional components:

<b>11.2</b>	DP 135 x 30 panel	4x
<b>12.2</b>	DMP 135 x 75 multi panel	4x

(Fig. C2.01a + Fig. C2.01b)

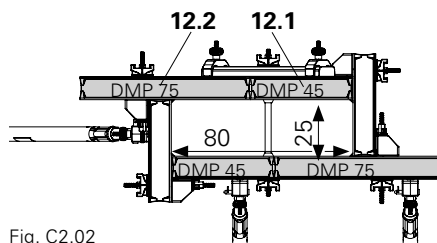

Fig. C2.02

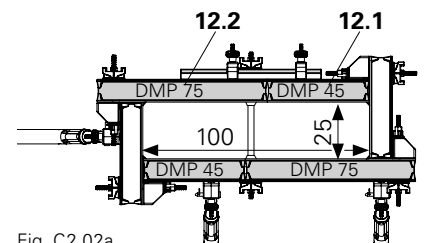

Fig. C2.02a

### L = 80 - 100 cm, with 1 row of ties\*\*

#### Additional components:

<b>12.1</b>	DMP 135 x 45 multi panel	4x
<b>12.2</b>	DMP 135 x 75 multi panel	4x

(Fig. C2.02 + Fig. C2.02a)

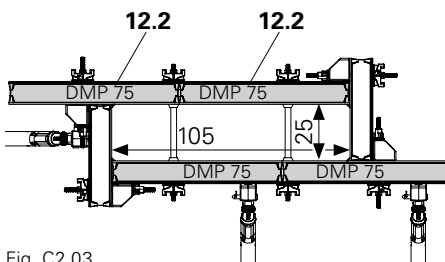

Fig. C2.03

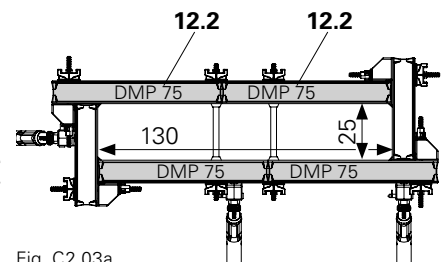

Fig. C2.03a

### L = 105 - 130 cm, with 2 rows of ties\*\*

#### Additional components:

<b>12.2</b>	DMP 135 x 75 multi panel	8x
-------------	--------------------------	----

(Fig. C2.03 + Fig. C2.03a)

\* Dependent on wall thickness.

\*\* Not taking into account horizontal connections.

## C2 Shear walls

**L = 135 - 155 cm, with 3 row of ties\*\***

**Additionally required components:**

<b>11.2</b> DP 135 x 30 panel	4x
<b>12.2</b> DMP 135 x 75 multi panel	8x

(Fig. C2.04 + Fig. C2.04a)

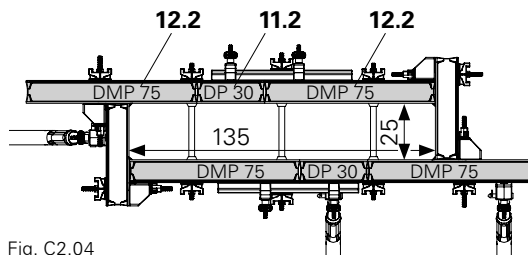

Fig. C2.04

**L = 160 - 175 cm, with 3 row of ties\*\***

**Additionally required components:**

<b>12.1</b> DMP 135 x 45 multi panel	4x
<b>12.2</b> DMP 135 x 75 multi panel	8x

(Fig. C2.05 + Fig. C2.05a)

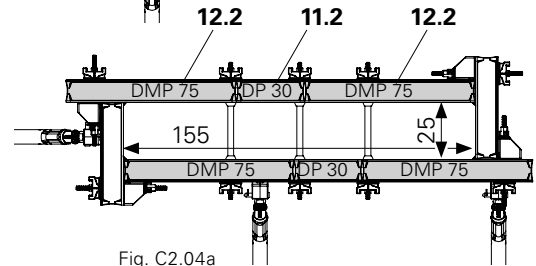

Fig. C2.04a

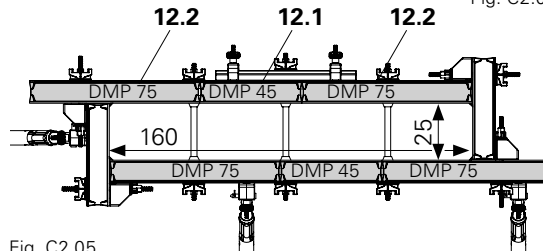

Fig. C2.05

**L = 180 - 205 cm, with 4 row of ties\*\***

**Additionally required components:**

<b>12.2</b> DMP 135 x 75 multi panel	12x
--------------------------------------	-----

(Fig. C2.06 + Fig. C2.06a)

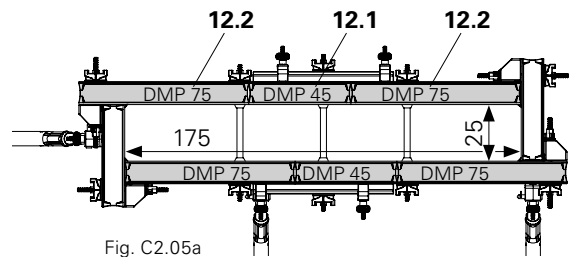

Fig. C2.05a

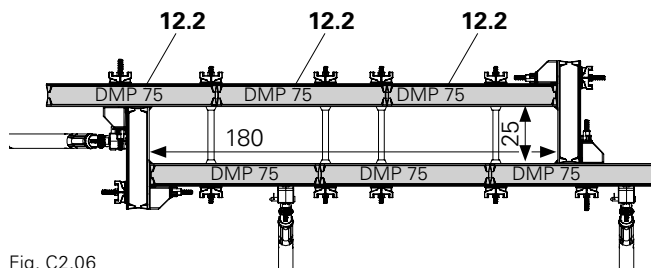

Fig. C2.06

**Components per row of ties:**

<b>50</b> DW 15 tie rod	4x
<b>41</b> DR 22 spacer tube	4x
<b>42</b> Cone DR 22	8x
<b>54</b> DW 15 wingnut counterplate	8x

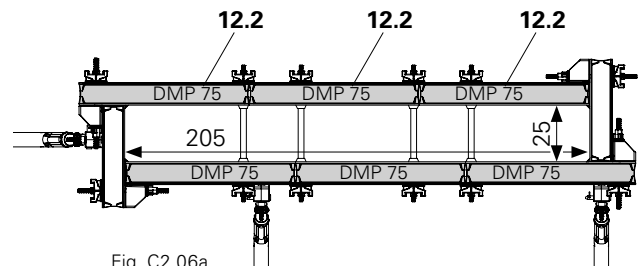

Fig. C2.06a

\* Dependent on wall thickness.

\*\* Not taking into account horizontal connections.

## DUO attachment parts and couplers



- Check the positions of ties and wing-nut counterplates. Every wingnut counterplate must overlap the vertical joint of both panels (**10**) by a minimum of 12 mm. If not, install a DUO 62 compensation waler (**25**).
- Connect every vertical panel joint from both sides with 4 DUO couplers (**21**) each. (Fig. C2.07)
- For panel connections, see section A3 Panel connections and C1 Column formwork.
- When working on areas at great heights, choose a safe working area, e.g. mobile scaffolds, see section D2 Shuttering. (Fig. D2.13).
- If the long side of the shear wall ends with a DP 30 panel or DMP 45 multi panel (**12.1**), install the DUO 62 compensation waler (**25**) upside down. This will prevent any overlapping with the corner connections.
- Mount DUO tube holders (**24**) at the connection points of the panels. (Fig. C2.07a + Fig. C2.07b)

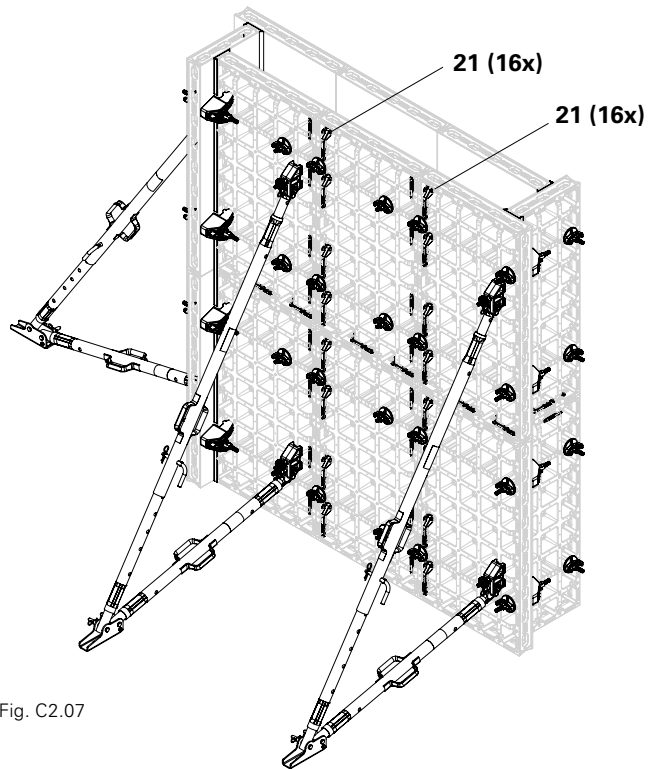

Fig. C2.07

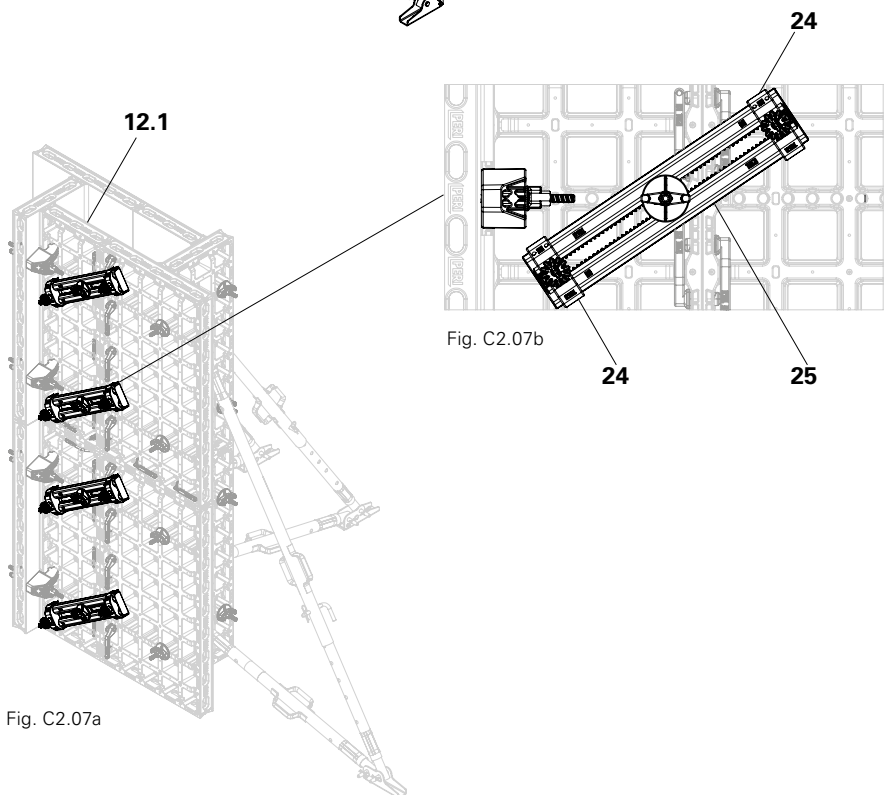

Fig. C2.07a

Fig. C2.07b

## Safety equipment

### Installation

See section B4 Working and concreting scaffolds.

When assembling at great heights, choose a safe working area, e.g. mobile scaffolds, see section D2 Shuttering (Fig. D2.13).

### Striking



#### Caution

Heavy components!

Components may fall down while they are being carried or may tilt during striking and cause injuries!

- ⇒ Retract components only when the concrete has sufficiently hardened and the person in charge has given the go-ahead for striking to take place.
- ⇒ Take into account the weight of two connected panels. Have panels transported/carried by two persons.
- ⇒ Secure panels against tilting and wind forces!



- When working on areas at great heights, choose a safe working area, e.g. mobile scaffolds, see section D2 Shuttering (Fig. D2.13).
- Start the striking process at a panel unit without push-pull props.
- Use the DUO stripping lever (44) during the striking process, see section A4 Additional accessories, under DUO stripping lever. (Fig. C2.08)

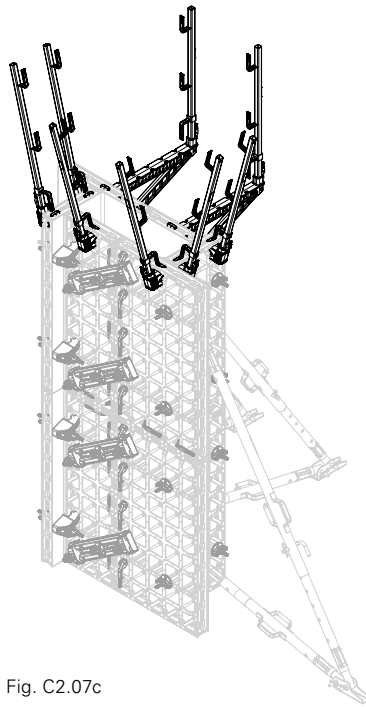

Fig. C2.07c

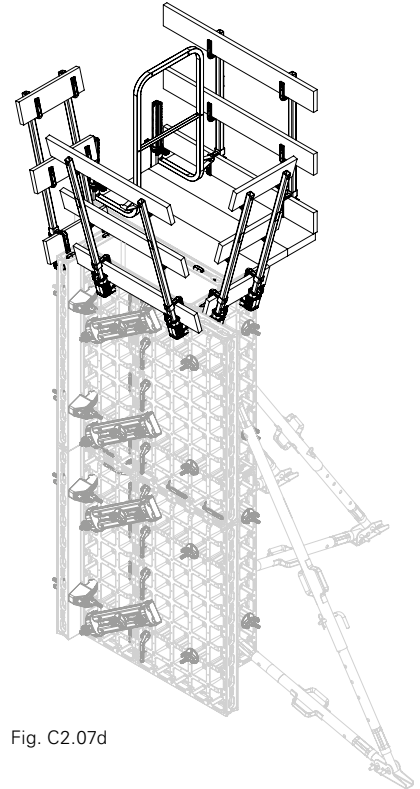

Fig. C2.07d

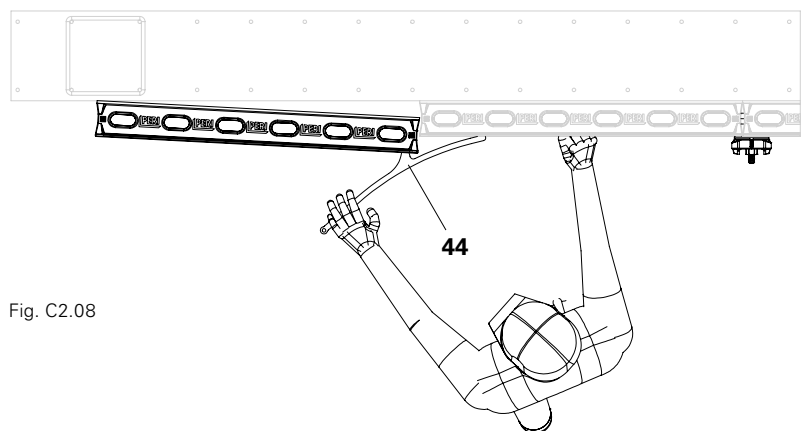

Fig. C2.08

### Dismantling

1. Remove safety devices, e.g. working and concreting scaffolds or protection against lifting.
2. Remove the DUO corner connector (**23**) on both sides of a lateral panel element.
3. Move, clean and transfer the panel unit to the next place of operation.
4. Remove the DUO coupler (**21**) on the vertical joint to the next panel unit without push-pull props, and move the panel unit.
5. Move further panel units without push-pull props in the same way.
6. On the remaining panel units, first dismantle the push-pull props and kicker braces, and then remove the panel unit.
7. On further panel units, remove push-pull props and kicker braces, and then move panel units.
8. For panel cleaning instructions, see section E1 Cleaning and maintenance.  
(Fig. C2.09)

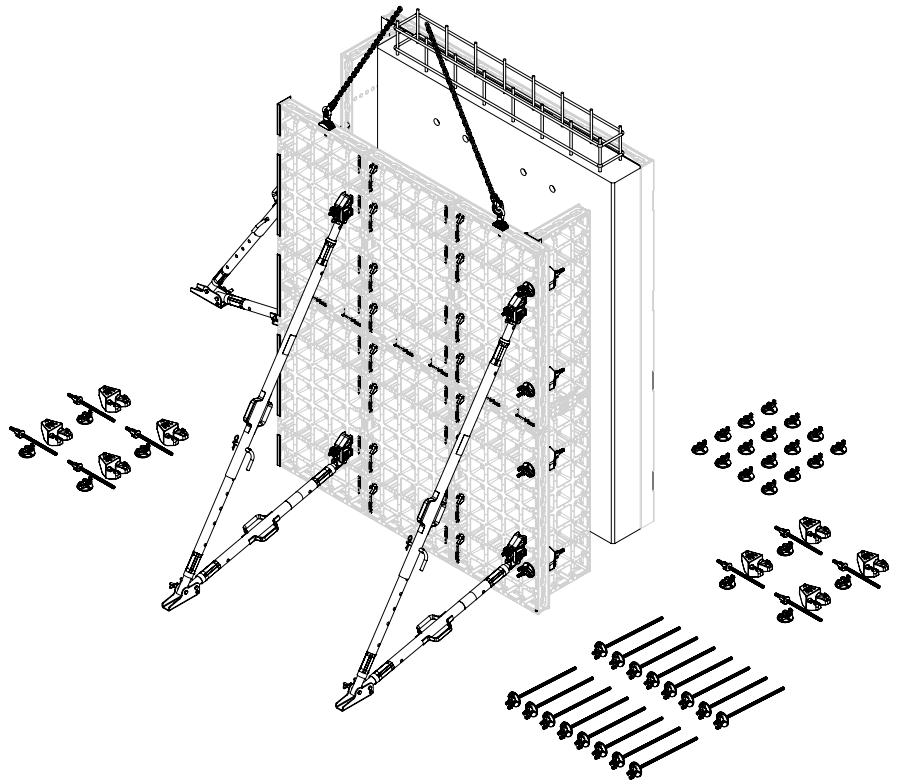

Fig. C2.09



The DUO accessories bag (art. no. 31205), which is used to store various DUO accessories, can be used to take additional accessories along with you.



## Overview

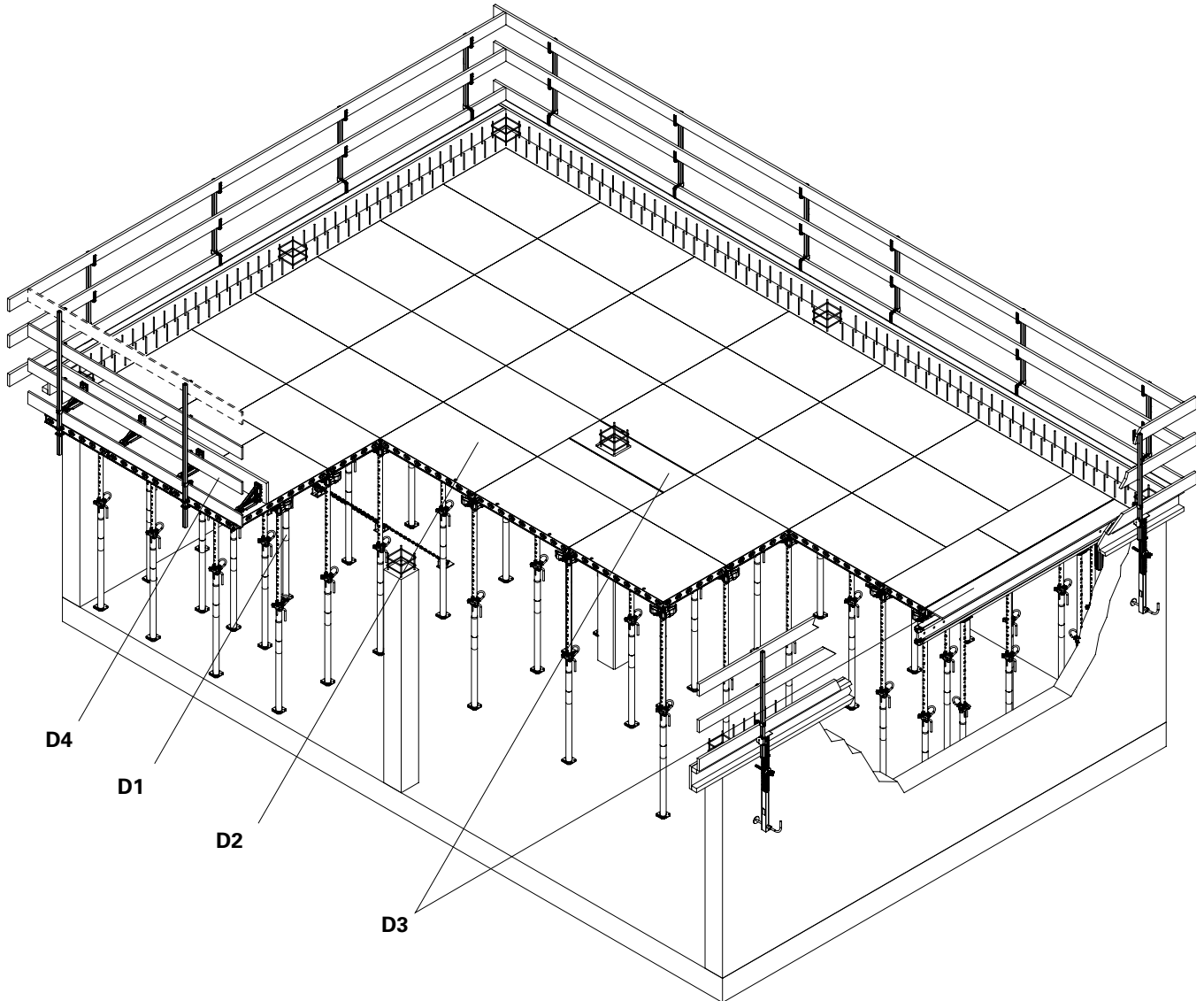

### Slab formwork

Safety instructions	121		
D1 System components	122		
Propheads	122		
Layout of DFH propheads	123		
Layout of DBH backpropping heads	123		
Slab props	123		
DUO shuttering aids	124		
DUO wall holders 82	125		
DUO prop adapters	126		
D2 Shuttering	128		
General	128		
DFH system propheads	129		
DBH system backpropping heads	133		
		D3 Compensations	136
		– for walls	136
		– around columns	138
		– in case of backpropped slabs	140
		D4 Cantilevers, guardrails	141
		– with DFH propheads	141
		– with DBH backpropping heads	143
		D5 Striking	145
		– with DFH propheads	145
		– with DBH backpropping heads	146
		D6 Slab formwork with DUO carrier racks	148
		Additional system components	148
		Shuttering	151
		Striking	158

## Safety instructions

### System-specific

#### General

Retract components only when the concrete has sufficiently hardened and the person in charge has given the go-ahead for striking to take place.

Only use PERI lifting accessories.

Check the usability by referring to the production date. Remove and dispose of components that have exceeded the period of usability.

Anchoring is to take place only if the anchorage has sufficient concrete strength.

Seal the tie points of the panels with plugs.

#### Slab system

The max. permissible slab thickness is 30 cm. Take into account the permissible prop loads.

The load-bearing capacity of the slabs that have been completed must be activated so as to avoid overloading of the slab props during vertical concreting cycles. For this, free deflection capability is required for these components. This can be done by releasing and re-installing all slab props available.

The load-distributing support used, such as planking, must match the respective base used. If several layers are required, planks are to be arranged crosswise.

The actual prop loads must be safely transferred using slab props with a sufficient load-bearing capacity or shoring systems.

When storing heavy items on the formwork, the load-bearing capacity must be taken into consideration.

Cantilevers may only be accessed when the bracing has been mounted.

The horizontal fixed position of the slab formwork must be guaranteed. This is provided by circumferential walls and pre-concreted beams. Otherwise, transfer of the horizontal loads has to be guaranteed by means of other measures provided by the contractor (e.g. bracing). Load assumptions for horizontal loads in accordance with EN 12812.

With wind speeds of 26 km/h and more, the panels must be connected with DUO couplers to form larger units.

For unfavourable structure geometries or larger wind speeds, additional securing measures are to be implemented, e.g.:

- ballast,
- bracing,
- dismantling the formwork etc.

Wind speeds for which additional measures should be taken, must be determined in a project-related manner as part of a risk assessment.

## Propheads

The DUO DFH prophead (**31**) and DBH backpropping head (**42**) are suitable for props with end plates measuring 120 x 120 mm and with a thickness of 5 - 8 mm.

When used in combination with DFP filler panels (**17**), the backpropping head allows for the placement of slab props for the purpose of backpropping, see section D5 Striking.

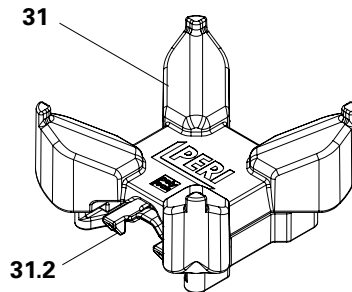

Fig. D1.01

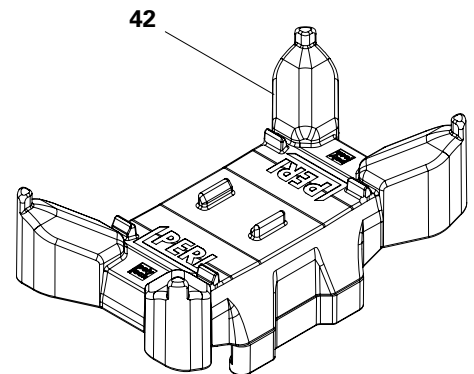

Fig. D1.01a



### Warning

Moving components!

There is a risk of crushing during assembly and disassembly!

- ⇒ Position one hand on the prop tube and the other hand on the prophead.
- ⇒ Wear protective gloves!

### Installation

Push the prophead with the locking clip (**31.2**) onto the end plate of the prop until the locking clip (**31.2**) clicks into place on the edge of the end plate. (Fig. D1.01b + Fig. D1.01c)

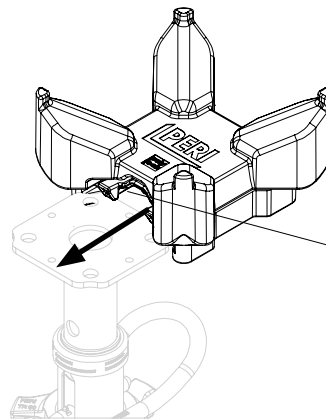

Fig. D1.01b

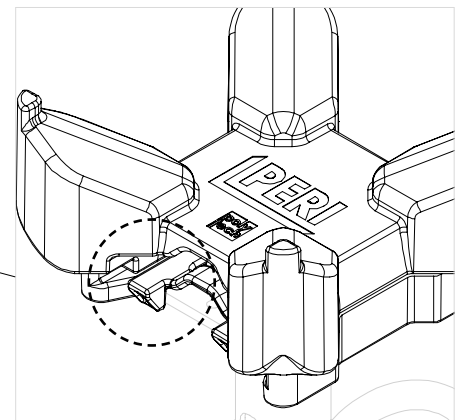

Fig. D1.01c



Has the locking clip clicked into place?

### Dismantling

1. Place one hand on the prophead with the other hand firmly holding the prop tube.
2. Lift the locking clip (**31.2**) with one finger of the upper hand and withdraw the DFH prophead (**31**). (Fig. D1.01d)

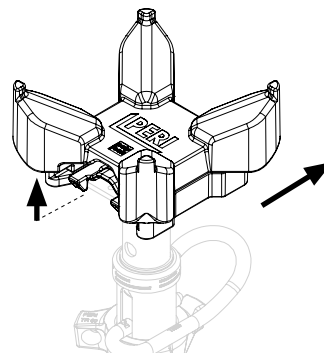

Fig. D1.01d

## Layout of DFH propheads

The DUO DFH prophead (**31**) can be used in different ways on the DP panel (**10**):

- above a frame strut, (Fig. D1.02a)
- above 2 DP panels (**10**), for connecting the panel edges, (Fig. D1.02b)
- above 4 DP panels (**10**), for connecting corners. (Fig. D1.02c)

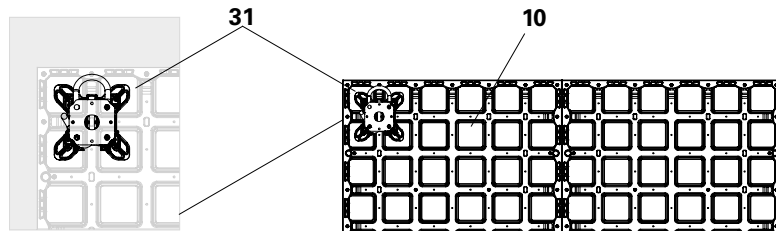

Fig. D1.02a

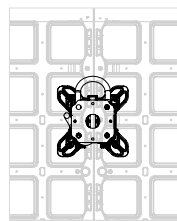

Fig. D1.02b

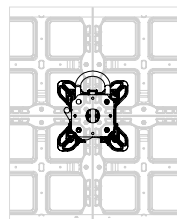

Fig. D1.02c

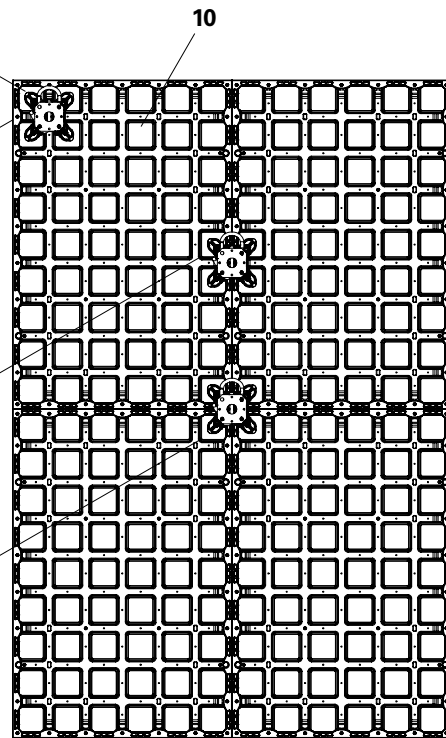

Fig. D1.02

## Layout of DBH backpropping heads

Always install the DBH backpropping head (**42**) crosswise to the main direction of the panel:

- above 2 DP panels (**10**), for connecting panel edges. (Fig. D1.03a)
- above 4 DP panels (**10**), for connecting corners. (Fig. D1.03b)
- above 2 panel corners and one panel edge with change of direction. (Fig. D1.03c)

## Slab props

PERI ERGO-B slab props are recommended for slab formwork that uses the DUO system.

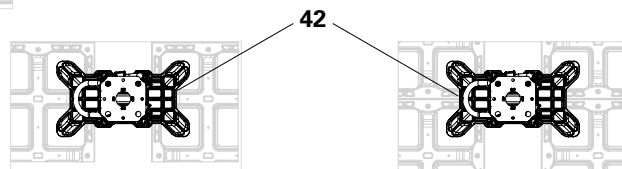

Fig. D1.03a

Fig. D1.03b



### Warning

The component may end up being subjected to excessive loads!

The component could collapse!

⇒ Take into account the permissible loads of the slab props (see PERI F1 Tables)!

⇒ The max. permissible slab thickness is 30 cm!

### Preparation of the slab props

1. Extension length of the slab prop with
  - DFH prophead (**31**): clear room height minus 14 cm.
  - DBH backpropping head: clear room height minus 17.5 cm.
2. Push DFH prophead onto the end plate of the prop. The locking clip secures the prophead.
  - The slab props are now ready for use.

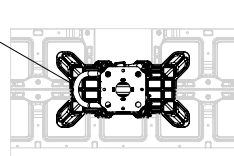
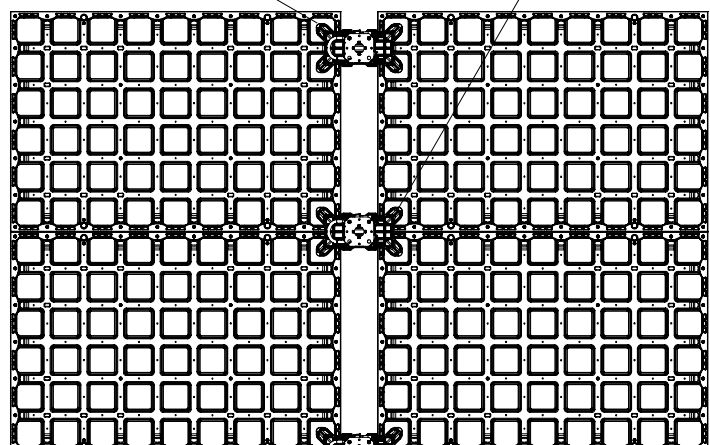

Fig. D1.03c

Fig. D1.03

## DUO shuttering aids



- Shuttering, see section D2 Shuttering.
- Striking, see chapter D5 Striking.

The DUO shuttering aid (**37**) is used to assemble and disassemble the DUO DP panels (**10**). The length is adjustable in 7.5 cm increments from 2.15 m to 3.85 m. (Fig. D1.04).

### Releasing the panels

1. Spindle out the props by max. 2 cm.
2. Insert both flanges (**37.1**) of the shuttering aid into the connector pockets (**10.2**) of the DP panel.
3. Pull the DP panel (**10**) down onto the prophead and prop it up again on the DUO shuttering aid (**37**). (Fig. D1.04a + Fig. D1.04b)
4. Remove props

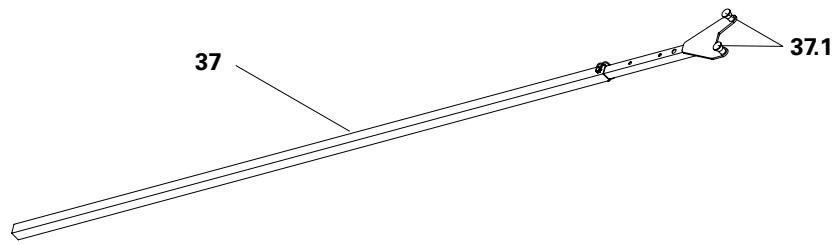

Fig. D1.04

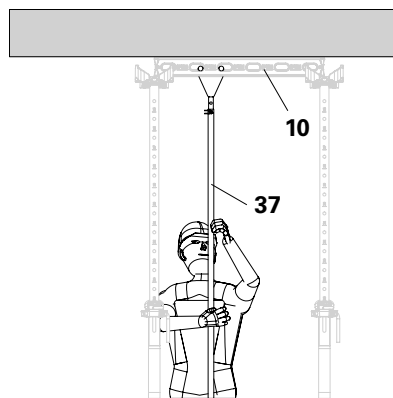

Fig. D1.04a

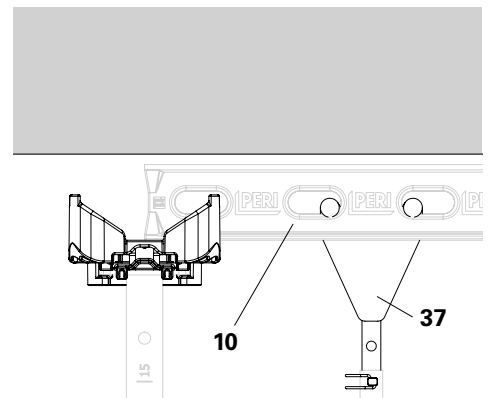

Fig. D1.04b

## DUO 82 wall holders



### Warning

During assembly, there is no side protection at the level of the formlining side!

A fall can result in serious injury.

⇒ Do not enter the forming area if the horizontal holder of the formwork has not been mounted!

⇒ Safely transfer the horizontal loads.

The DUO 82 wall holder (**26**) serves as a horizontal holder of the slab formwork. It can be mounted in both horizontal and transverse directions.

### Installation

Mount the first DP panel on both walls with the DUO 82 wall holder (**26**).

For assembly, select a tie hole that enables adjustment of the DUO 82 wall holder (**26**) to the required height.

1. Push the tie rod with the wingnut counterplate (**54**) through the available tie hole on the opposite side of the wall.
2. Place the DUO 82 wall holder (**26**) on the tie rod with the flange facing upwards and the flat side towards the wall.
3. Tighten the DUO 82 wall holder (**26**) with the DW 15 wingnut counterplate (**54**).  
(Fig. D1.05)
4. Cover protruding tie rods with protective caps.
5. Install the DUO 82 wall holder (**26**) in both directions in every third DP panel.

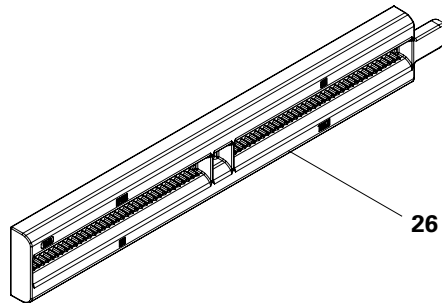

Check that the wall holders (**26**) are securely positioned.

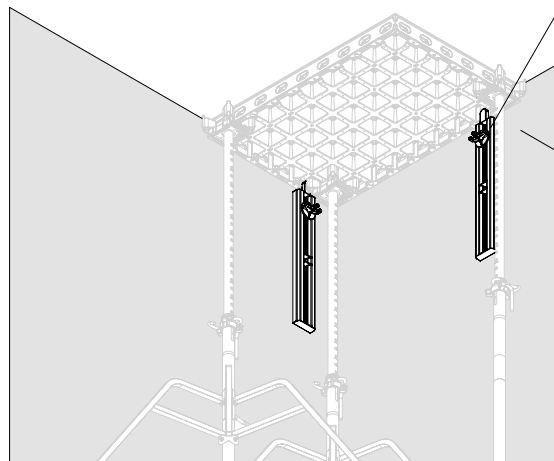

Fig. D1.05

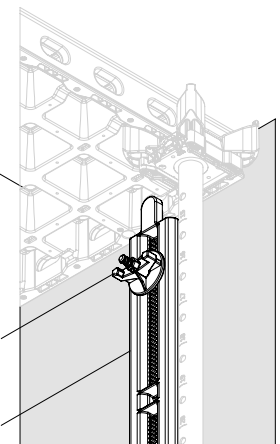

Fig. D1.05a

## DUO prop adapters

**Permissible load: 12.2 kN**

The DUO prop adapter (**86**) is a component that allows you to use prop end plates with dimensions from 120 x 120 mm up to 150 x 150 mm (e.g. MULTIPROP MP (**48**)) in the DUO system. It can be used with the DUO DFH heads (**31**) and DBH heads (**42**) and can also support DFP panels (**17**) (emergency support solution for slabs). (Fig. D1.06 – Fig. D1.09)

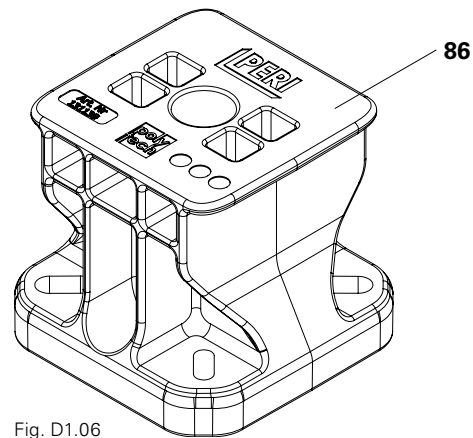

Fig. D1.06

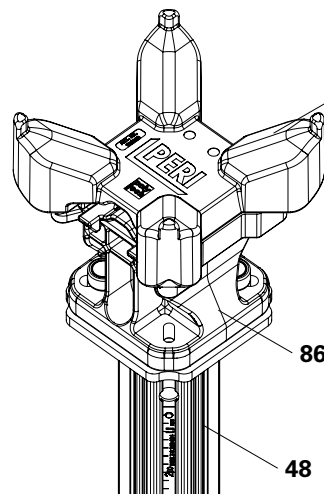

Fig. D1.07

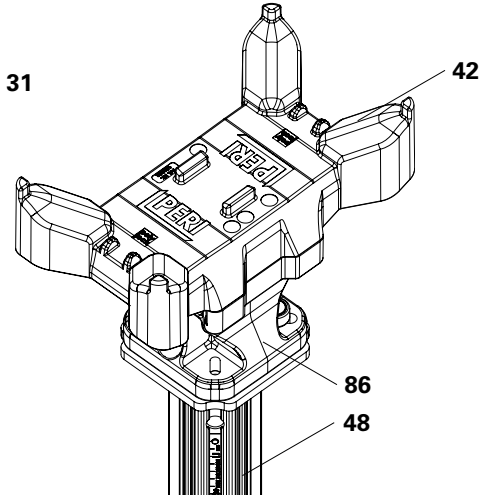

Fig. D1.08

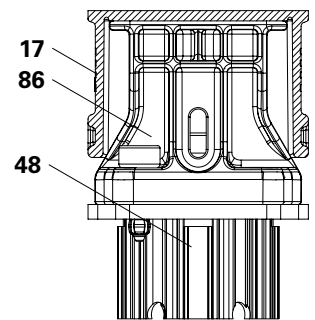

Fig. D1.09

The geometry of the DUO prop adapter allows it to be affixed to slabs with different thicknesses, dimensions, hole positions and/or hole diameters.

### Fastening

The prop adapter has four slots in its base with two different dimensions: 2 slots with a diameter of 14 mm and 2 slots with a diameter of 10 mm which sit diagonally opposite each other. These fit onto end plates with square-shaped hole spacing of 80 mm and 100 mm. (Fig. D1.10)

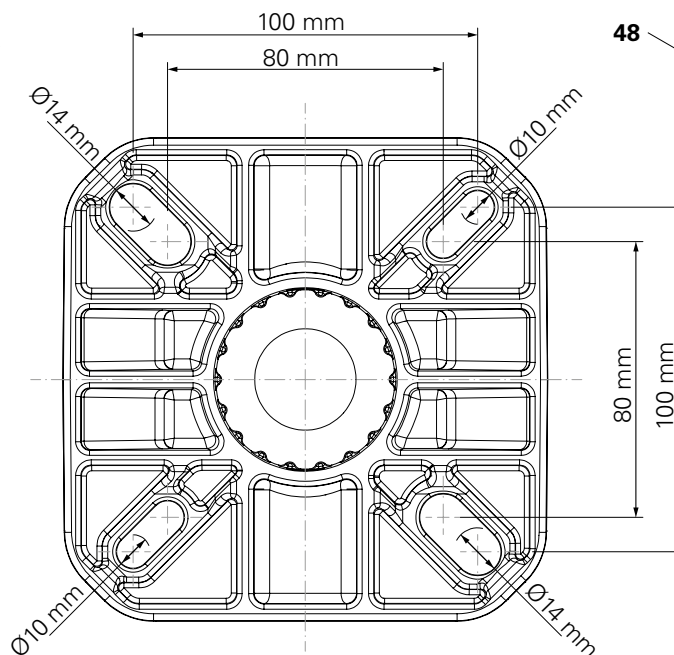

Fig. D1.10

The DUO prop adapter (**86**) fits onto the UJB 38-50/30 screw jack foot (**49**) if the screw jack foot is inserted at the top.  
(Fig. D1.11)

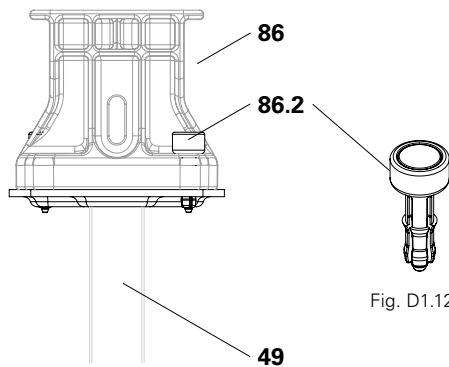

Fig. D1.11

Fig. D1.12

The DUO prop adapter (**86**) also serves as a holder for tubes with a diameter of 48.3 mm, e.g. UVH (**36**). These are inserted into the opening that is specifically provided for this purpose (**86.3**).  
(Fig. D1.13 + Fig. D1.14)

The fastening can be established with universal rivets (**86.2**) or, alternatively, with nuts and bolts (**86.1**) (M12 for MULTIPROP, M8 for UJB 38-50/30 screw jack foot, M10 for UVH).

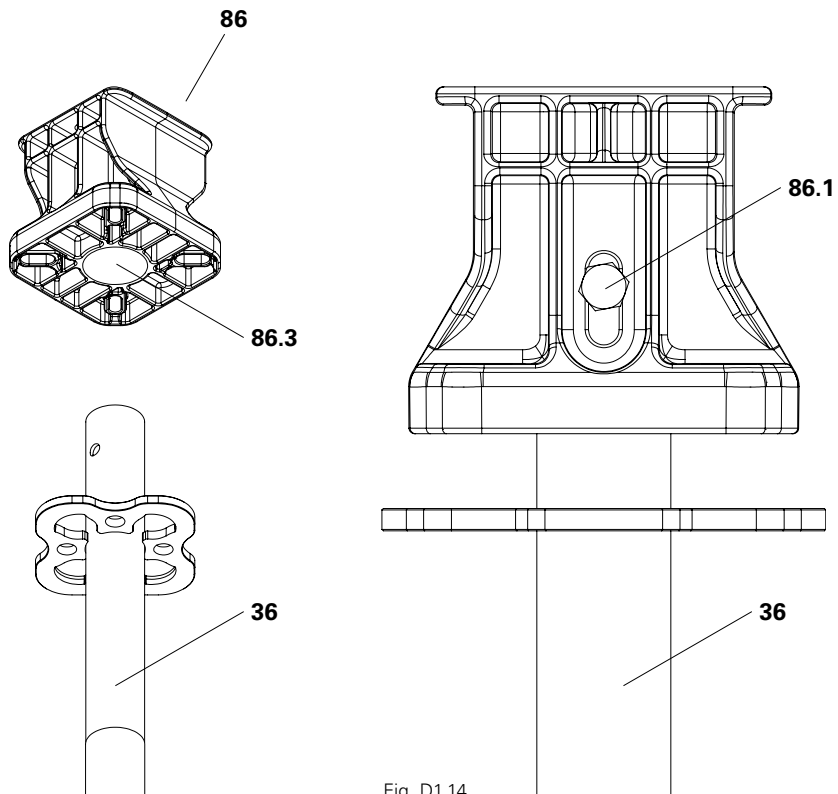

Fig. D1.13

Fig. D1.14



Use at least 2 nuts and 2 bolts and fit these diagonally opposite to each other.

If you choose to use universal rivets (**86.2**), the DUO prop adapter (**86**) should also be fitted using at least two universal rivets, placed diagonally opposite to each other.



- Observe the Instructions for Assembly and Use for the supporting systems, e.g. MULTIPROP, PERI UP Flex etc.
- Observe the type tests for MULTIPROP, MULTIPROP system, PERI UP Flex.
- Shoring must be assembled in accordance with valid Instructions for Assembly and Use, e.g. PERI UP Flex shoring tower or MULTIPROP system.



Observe the loads that are described in the Instructions for Assembly and Use for the respective props (e.g. PEP Ergo slab props).

Use of the prop adapter has no impact on the maximum loads of the shoring.

## General



### Warning

- Loose components that are present during assembly and disassembly may fall down! Falling components can cause serious injuries.
  - ⇒ Wear a safety helmet.
  - ⇒ Wear safety shoes.
  - ⇒ Wear safety gloves.
- Components may topple over or fall down in high winds! Toppling or falling components can cause serious injuries.
  - ⇒ Larger panel units are to be formed with wind speeds of 26 km/h and more. For this, connect panels to each other using DUO couplers, and secure by means of bracing or ballasting.



### Warning

Risk of slipping at great heights due to the formwork oil applied! This can result in serious injury!

- ⇒ Be careful when accessing forming areas after spraying!
- ⇒ Weather conditions are to be taken into account!

Insert the long side of the panels **(10)** in the direction of the longer wall. Position the slab props in such a way that it is possible to handle the G hooks and keep them secured.

Seal the tie points of the panels with plugs.

Start shuttering from a corner.

## DFH system propheads

### Starting bay

1. Erect two props with DFH propheads (**32**) and secure with tripods. (Fig. D2.01)  
Set up the first prop in the corner with a distance of 15 cm from both walls. (Fig. D2.01a)
2. Set up the second prop at the shorter wall with a spacing of 75 cm to the first prop. (Fig. D2.01a)
3. Hook the DP panel (**10**) into DFH propheads. (Fig. D2.02)  
Hook the frame of the DP panel into the teeth of the DFH prophead.
4. Push the DP panel (**10**) upwards with the DUO shuttering aid (**37**) (Fig. D2.03) and position the panel on the shuttering aid. (Fig. D2.03a)
5. Place the third prop with DFH prophead (**32**) at the end of the panel in an inclined position from the inside and align outwards. Spacing 1.20 m (Fig. D2.04)
6. Remove the shuttering aid (**37**).
7. Secure the DP panel (**10**) on both walls with the DUO 82 wall holder (**26**). (Fig. D2.05)  
→ The starting bay is complete.

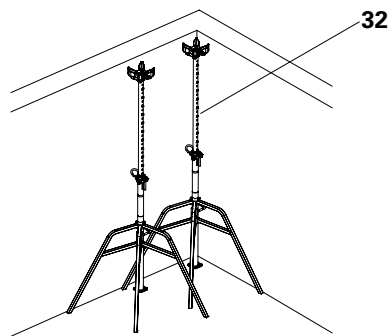

Fig. D2.01

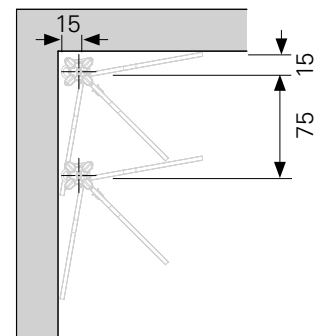

Fig. D2.01a

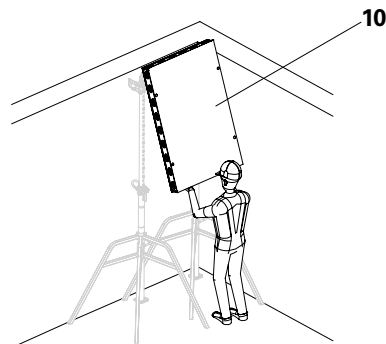

Fig. D2.02

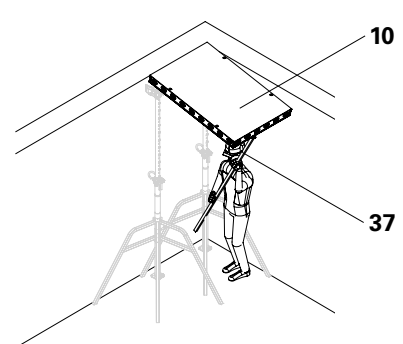

Fig. D2.03

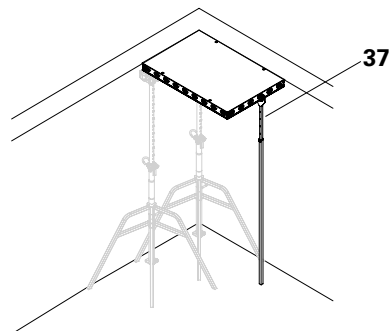

Fig. D2.03a

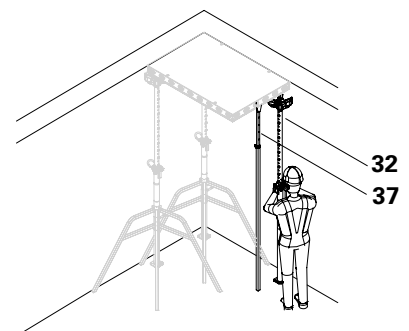

Fig. D2.04



- Alternatively, the starting bay can be set up with the PEP PRK frame (**45**) 75 and 120 instead of the tripods.
- Observe the Instructions for Assembly and Use for PEP Ergo slab props! (Fig. D2.05a)

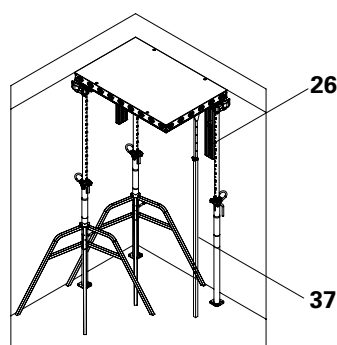

Fig. D2.05

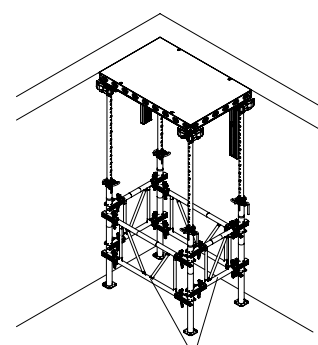

Fig. D2.05a

## First row



### Warning

During assembly, there is no side protection at the level of the formlining side!

A fall can result in serious injury.

⇒ Secure every third DP panel with the DUO 82 wall holder (**26**)!

⇒ Safely transfer the horizontal loads!

1. Erect the other DP panels (**10**) in the same way. (Fig. D2.06)

2. Position the slab prop with DFH prophead (**32**) below the long panel side, see the Slab Prop Plan. (Fig. D2.12)

3. Before compensating, hook the DFH prophead (**32**) of the last prop into the DP panel (**10**) using two teeth. Two teeth remain unused for the time being. (Fig. D2.07 + Fig. D2.07a)

4. Secure every third DP panel with the DUO 82 wall holder (**26**)! (Fig. D2.08)

→ The first row is now ready.

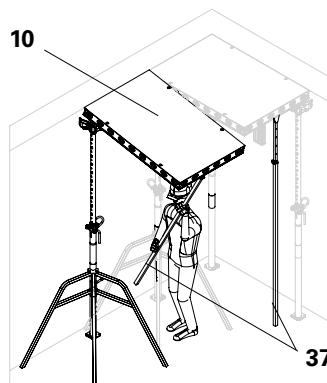

Fig. D2.06

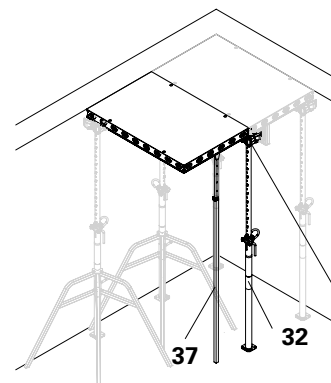

Fig. D2.07

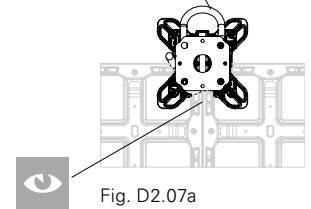

Fig. D2.07a

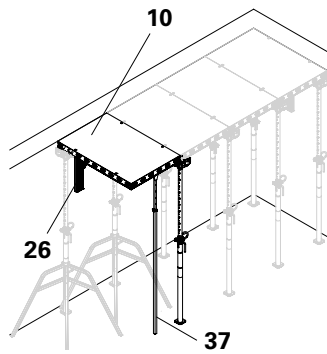

Fig. D2.08



- Reuse the tripod or PEP PRK frame in the next field.
- The slab formwork is set up row by row in the transverse direction. (Fig. D2.08)



The DFH prophead (**32**) must overlap the joint between both panels.

## Second row

1. Hook in the DP panels (**10**).  
(Fig. D2.09)
  2. Push the first DP panel (**10**) upwards using the DUO shuttering aid (**37**) and set it down on the shuttering aid. (Fig. D2.10)
  3. Place the slab prop with DFH pro-head (**32**) at the end of the panel in an inclined position from the inside and align outwards. Spacing 1.35 m.
  4. Remove the DUO shuttering aid (**37**).
  5. Erect the other DP panels (**10**) in the same way. (Fig. D2.11)
- The second row is now ready.

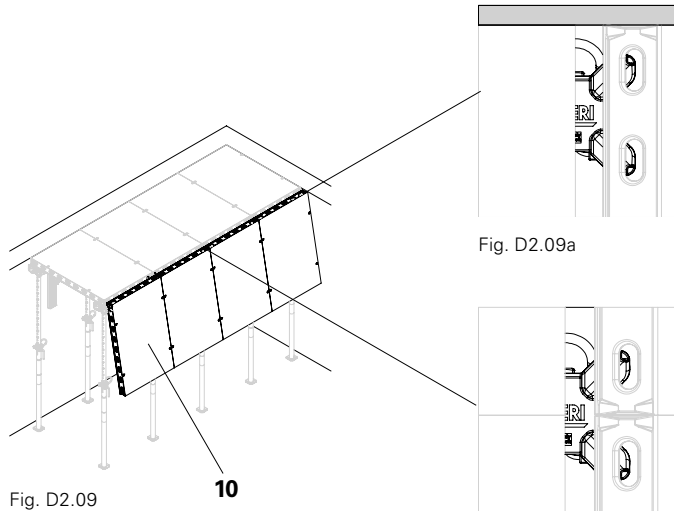

Fig. D2.09a

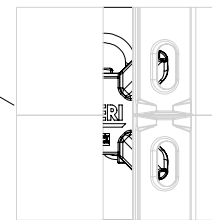

Fig. D2.09b

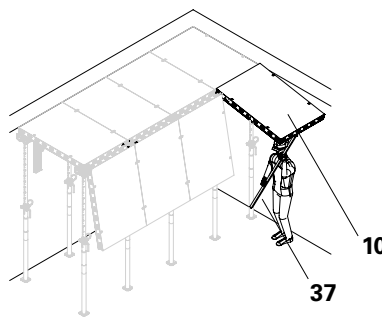

Fig. D2.10

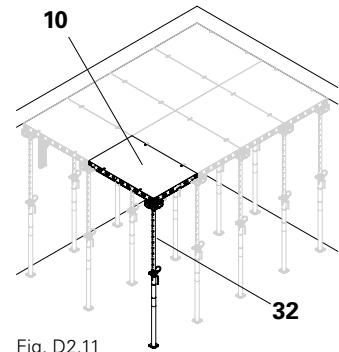

Fig. D2.11

## Additional rows

- Due to the recurring assembly sequence, always proceed in the same way.
- Secure every third panel row with the DUO 82 wall holder!
- Forming is carried out with the DP panel up to the compensation.
- Before compensating, hook the prohead of the last prop into the DP panel using two teeth. Two teeth remain unused for the time being, see section D3 Length compensations.



When working on areas at great heights, choose a safe working area, e.g. Alu-2 stripping carts. (Fig. D2.13)

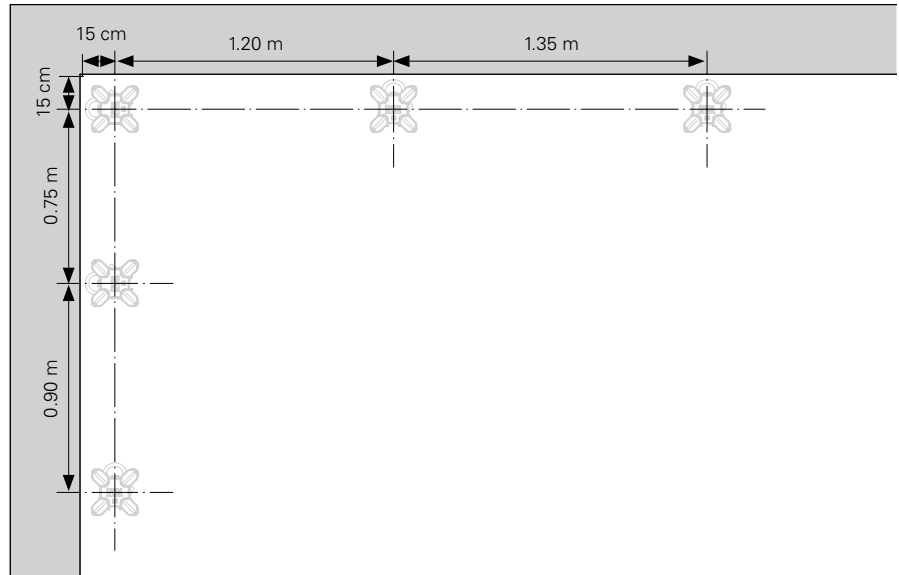

Fig. D2.12

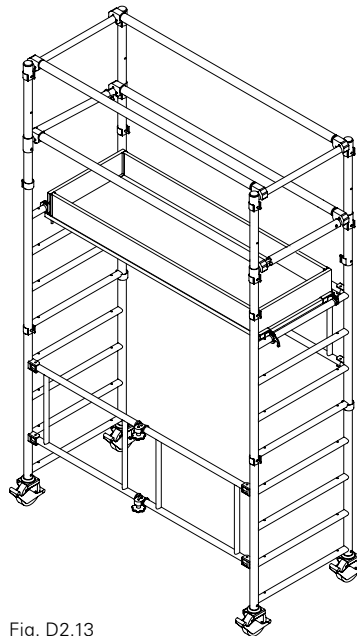

Fig. D2.13

## DBH system backpropping heads

### First row



#### Warning

During assembly, there is no side protection at the level of the formlining side!

A fall can result in serious injury.

- Secure every third DP panel (**10**) with the DUO 82 wall holder (**26**)!
- Safely transfer the horizontal loads!

Assembly of the starting bay takes place in a way that is similar to the description in DFH system prophead (**32**). Use the first row of props with DFH propheads on the short wall side.

1. Erect two props complete with DFH propheads (**32**).
2. Hook the DP panel (**10**) into the DFH propheads.
3. Push the DP panel upwards with the DUO shuttering aid (**37**) and position the panel on the DUO shuttering aid (**37**).
4. Place the third prop with the DBH backpropping head (**42**) at the end of the panel in an inclined position from the inside and align outwards. Spacing 1.275 m. Remove the shuttering aid.  
(Fig. D2.14)
5. Secure the DP panel (**10**) on both walls with the DUO 82 wall holder (**26**).
6. Complete the first row of panels in the same way.  
→ The starting bay is complete.

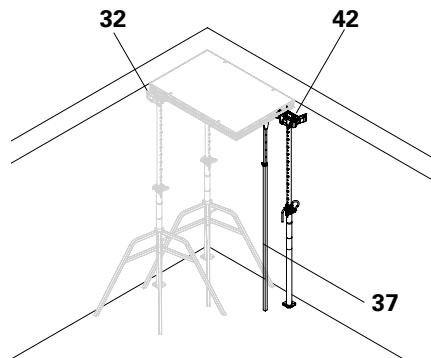

Fig. D2.14

## Second row

1. Attach the DP panels (**10**) to the backpropping head.
  - (Fig. D2.14a)
  2. Push the DP panel (**10**) upwards using the DUO shuttering aid (**37**) and set it down on the shuttering aid. (Fig. D2.14b)
  3. Place the slab prop with DBH backpropping head (**42**) at the end of the panel in an inclined position from the inside and align outwards. Spacing 1.50 m. (Fig. D2.14c)
  4. Remove the DUO shuttering aid (**37**) and replace it with a DBH backpropping head (**42**). (Fig. D2.14c)
  5. Erect the other DP panels (**10**) in the same way. (Fig. D2.14d)
- The second row is now ready. Erect additional rows of panels in the same way.

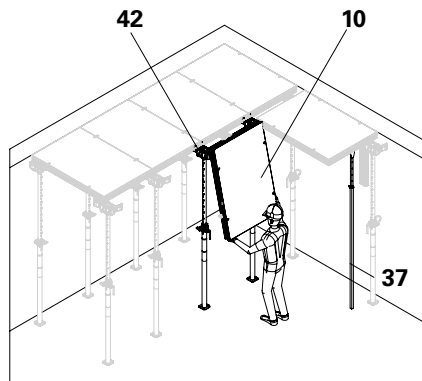

Fig. D2.14a

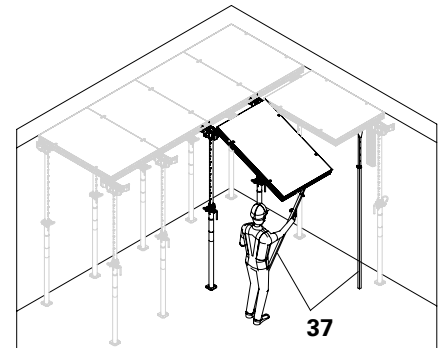

Fig. D2.14b

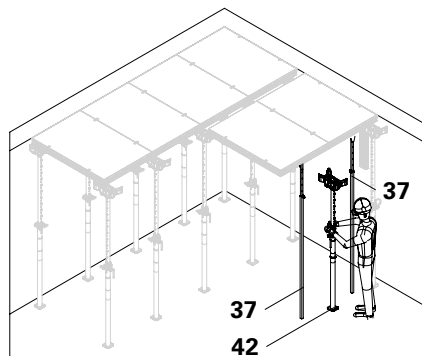

Fig. D2.14c

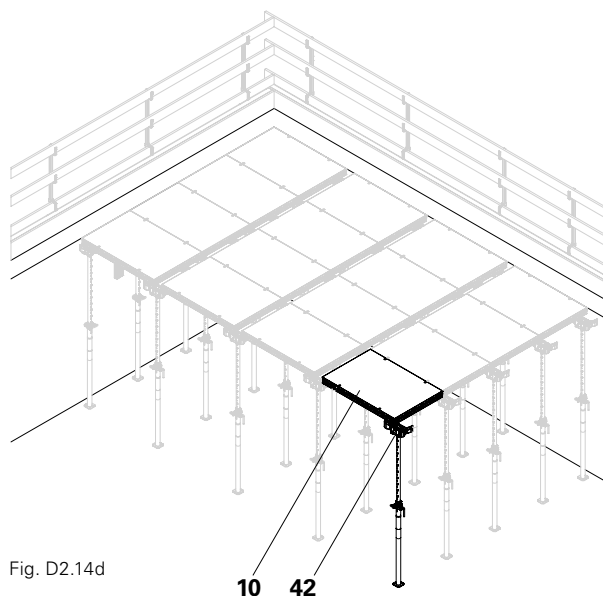

Fig. D2.14d



- Erect the rows of panels in such a way that the required space of 15 cm for the DFP filler panel is available.
- During formwork installation, the DP panel (**10**) must always be secured with a DUO shuttering aid (**37**) until it rests on all four slab props with DBH backpropping head (**42**).

## Inserting the DFP filler panels



### Warning

During assembly, there is no side protection at the level of the formlining side!

A fall can result in serious injury.

⇒ Secure the building edge.



- The length of the DFP filler panels (**17**) must always correspond to the panel width.
  - Filler panels must rest on the back-propping heads on both sides.
- (Fig. D2.15 – Fig. D2.15b)

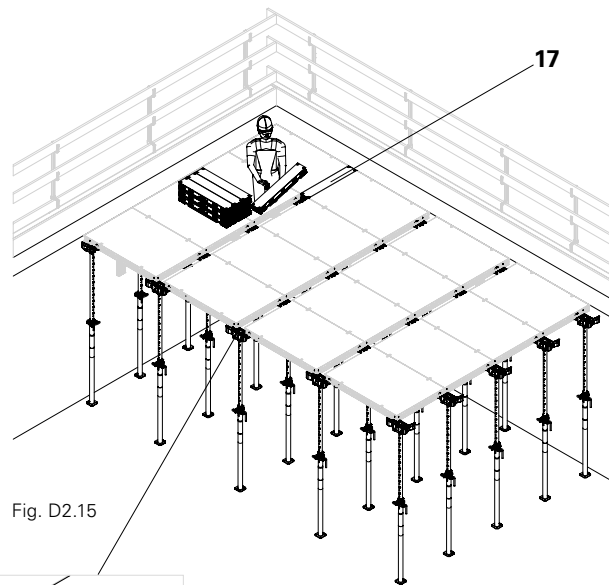

Fig. D2.15

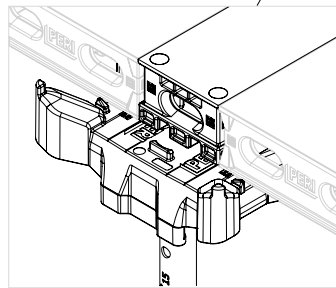

Fig. D2.15a

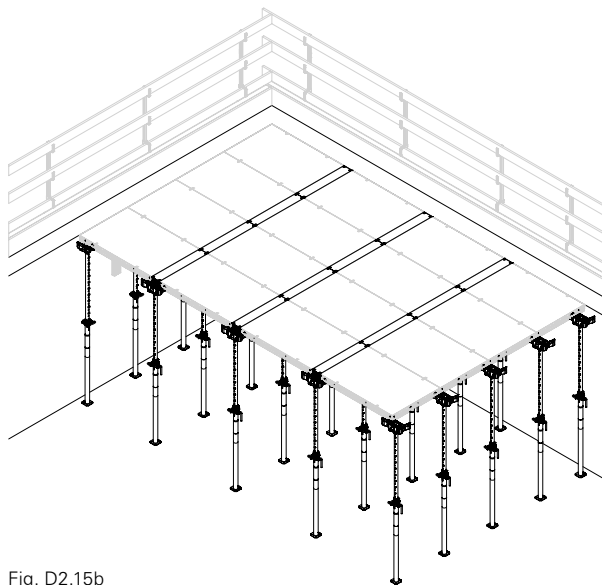

Fig. D2.15b

## Wall compensations



### Warning

During assembly, there is no side protection at the level of the formlining side!

A fall can result in serious injury.

- ⇒ Every panel must be supported in the corners by at least four slab props with DFH propheads (32).
- ⇒ Secure filler plates with nails in order to prevent movement!

### Preparation

1. Form the slab with the DP panel (10) to the greatest extent possible (Fig. D3.01), see also section D2 Shuttering.
2. Depending on the remaining dimension, select a standard panel (10) or a panel with a small width. The DP panel (10) is installed crosswise. Keep the compensation area as small as possible.
3. Mount the 18 DFS filler support (16) on the long panel side using 2 DUO couplers (21). The 18 DFS filler support (16) is equipped with teeth that grip into the connector pockets (10.2) of the DP panel. The teeth must point away from the concrete.

### Installation

1. Place the slab prop with DFH prophead (32) at the end of the panel in an inclined position from the inside and align outwards. Spacing 1.35 m (Fig. D3.01)
2. Hook the DP panel prepared with the filler support crosswise into the DFH propheads. The filler support must be pointing towards the wall. Push it upwards with the shuttering aid, and then position it on the shuttering aid (37). (Fig. D3.02)
3. Place the slab prop with DFH prophead (32) across the edge of the panel in an inclined position from the inside and align outwards. The distance from the wall is 15 cm. (Fig. D3.02a)
4. Remove the shuttering aid (37).

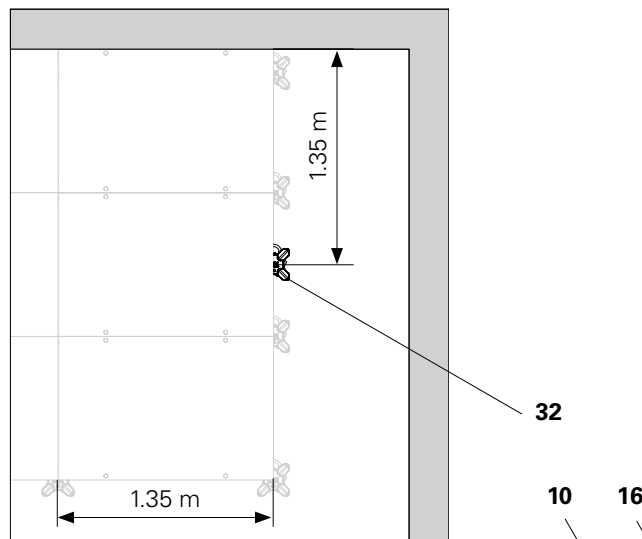

Fig. D3.01

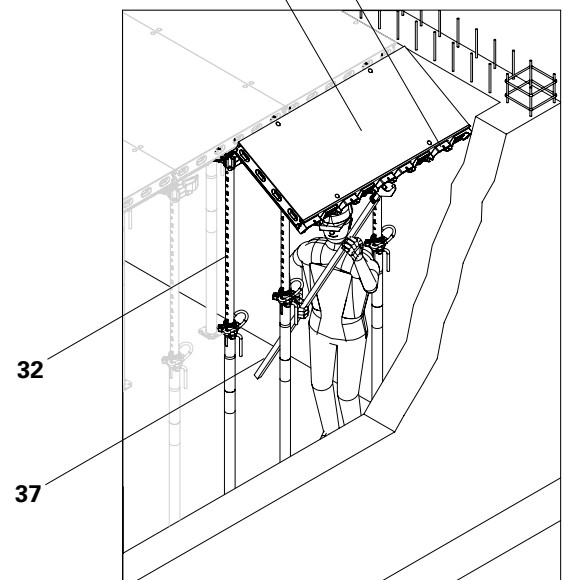

Fig. D3.02

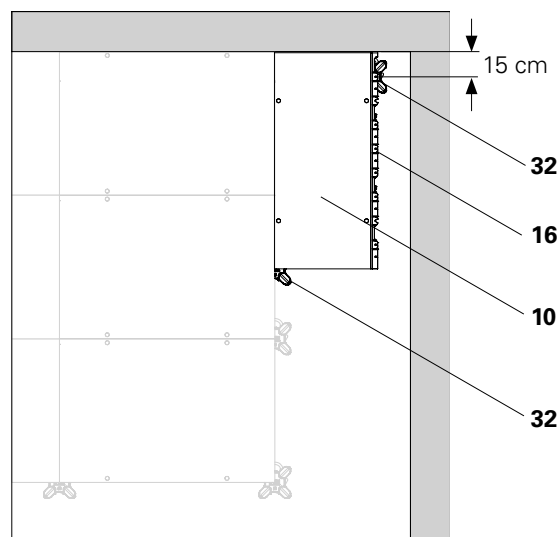

Fig. D3.02a

5. Fit the other DP panels in the same way.
6. Erect slab props (**34**) with a cross-head for accommodating the VT 20 girder (**35**) as close as possible to the wall.
- (Fig. D3.03)
7. Continuously fill the compensation area with 18 mm filler plates (**90**), and secure them on the VT 20 girder from the top with nails.
8. From below, screw the filler plate into place through the screw holes provided in the filler support using Torx 5 x 15 screws.
- (Fig. D3.04)

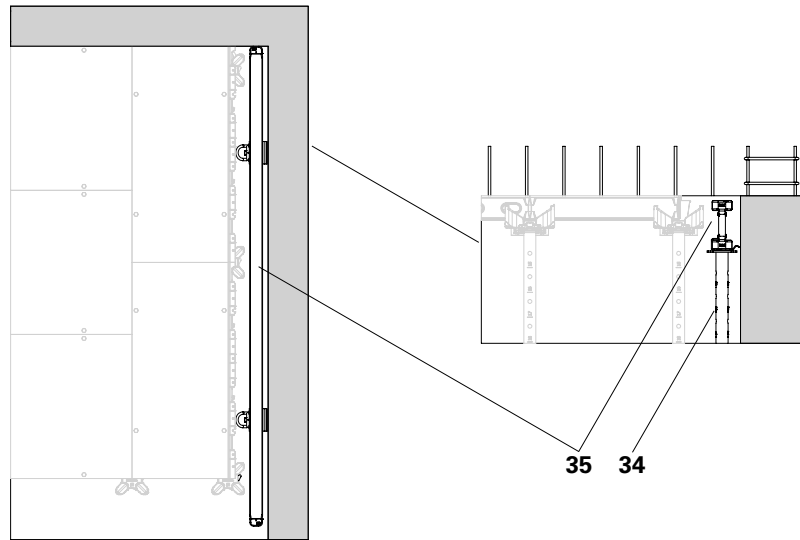

Fig. D3.03

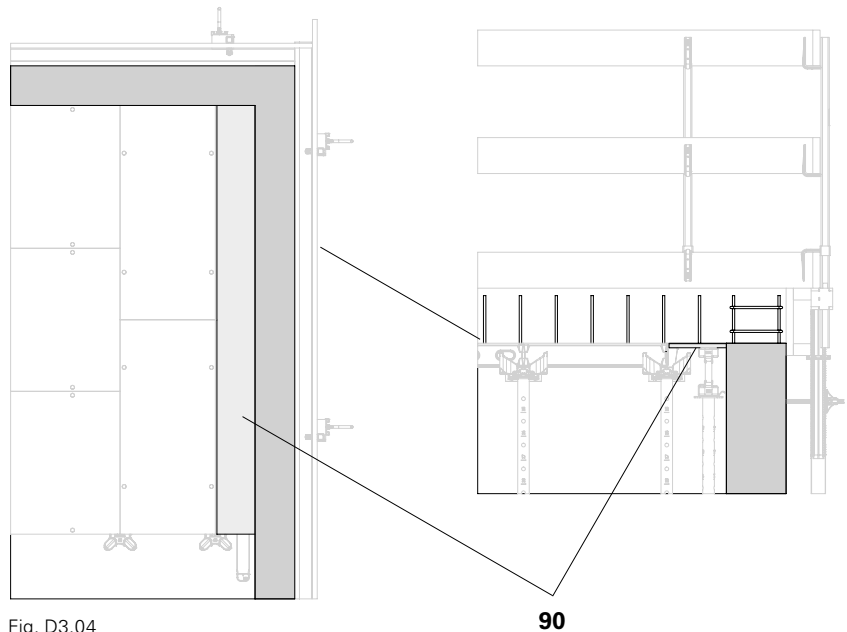

Fig. D3.04



As an alternative to the slab prop arrangement in (Fig. D3.05), additional slab props (**32**) are not required if:

- both DP panels overlap at the longer joint by no more than 45 cm,
- both DP panels are connected at the shorter joint with 2 DUO couplers (**21**). (Fig. D3.05a)

This alternative is also valid:

- for all other compensations or
- if the forming direction is changed.

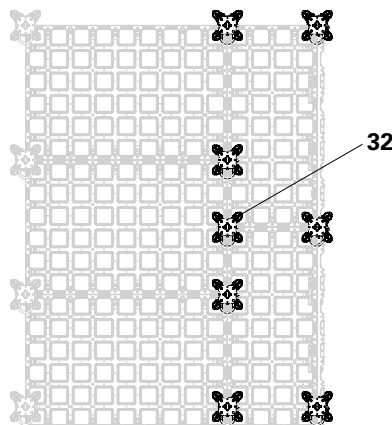

Fig. D3.05

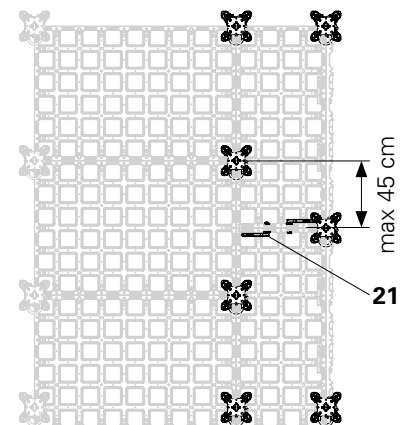

Fig. D3.05a

## Compensations around columns



### Warning

Unsecured components may topple over or collapse!  
Toppling or collapsing components can cause serious injuries.

- ⇒ Continuously close and secure the compensation area with filler plates.
- ⇒ Every panel must be supported in the corners by at least four slab props with propheads.
- ⇒ Secure filler plates with nails in order to prevent movement!

1. Form the slab with DP panels (10) as far as possible to the column, see section D2 Shuttering.
2. Depending on the remaining dimension, select a standard panel or a panel (10) with a small width. Distance to the column  $\geq 5$  cm. (Fig. D3.06a)
3. Mount the 18 DFS filler support (16) on the long panel side using 2 DUO couplers (21). (Fig. D3.06)  
The 18 DFS filler support (16) is equipped with teeth that grip into the connector pockets of the DP panel (10). The teeth must point away from the concrete.
4. Hook the DP panel (10) prepared with the filler support crosswise into the DFH propheads (31). The filler support must be pointing towards the column. Push upwards with the DUO shuttering aid (37) and position on the DUO shuttering aid (37). (Fig. D3.06)
5. Place the slab prop with DFH prophead (32) at the end of the panel in an inclined position from the inside and align outwards. (Fig. D3.06a)
6. Remove the shuttering aid.
7. Repeat steps 2 to 6 on the opposite column side. (Fig. D3.07)

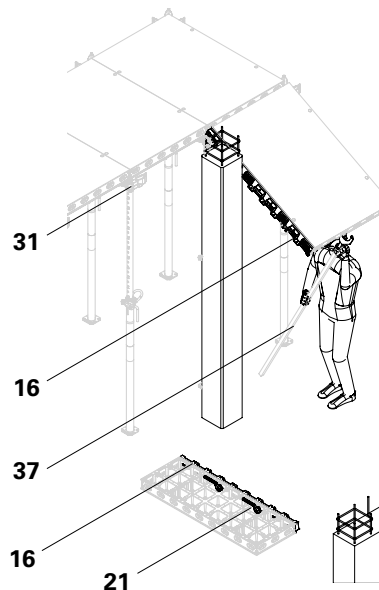

Fig. D3.06

### Components:

- 12 DP panel / DMP multi panel
- 16 18 DFS filler support
- 17 DFP filler panel
- 21 DUO coupler
- 32 DFH prophead
- 37 DUO shuttering aid
- 90 Filler plate
- 91 Square timber

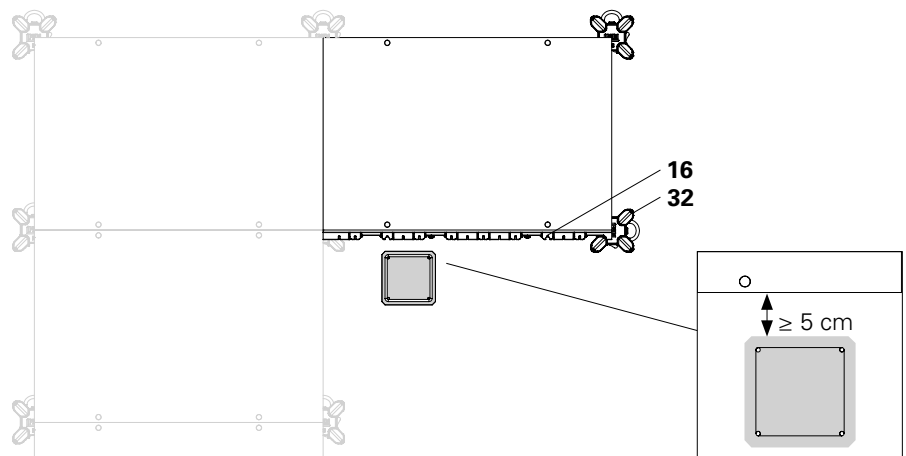

Fig. D3.06a

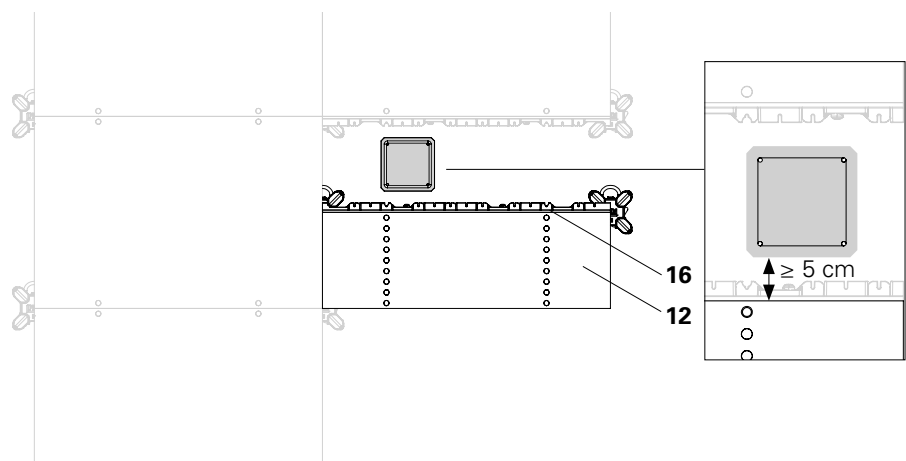

Fig. D3.07

8. Insert 75 x 50 square timber (**91**) in every possible position in the 18 DFS filler support (**16**).
9. From below, screw the square timber into place through the screw holes provided in the filler support using Torx 5 x 15 screws. (Fig. D3.08)
10. Continuously fill the compensation area with 18 mm filler plates (**90**), and secure them on the square timber from the top with nails. (Fig. D3.09)

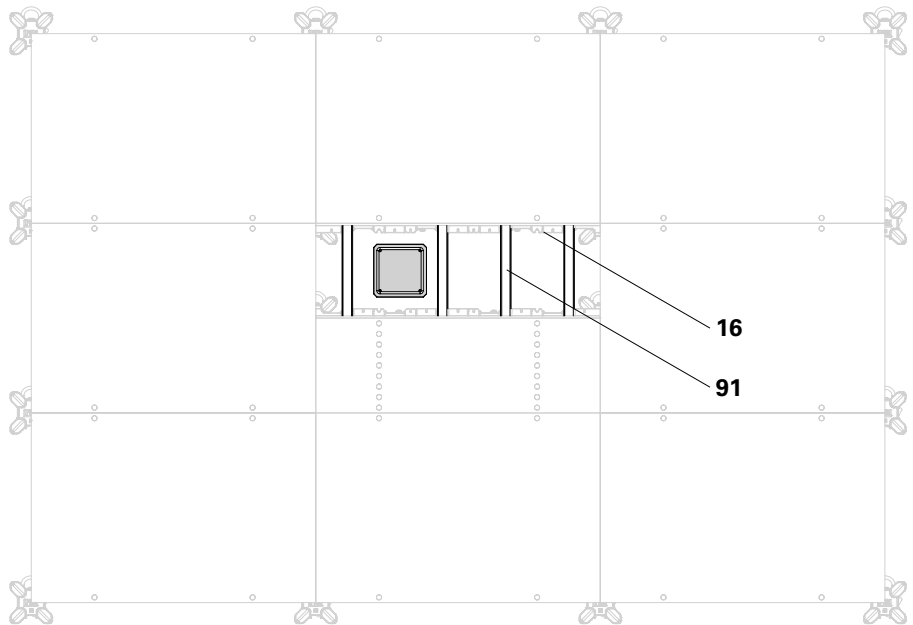

Fig. D3.08

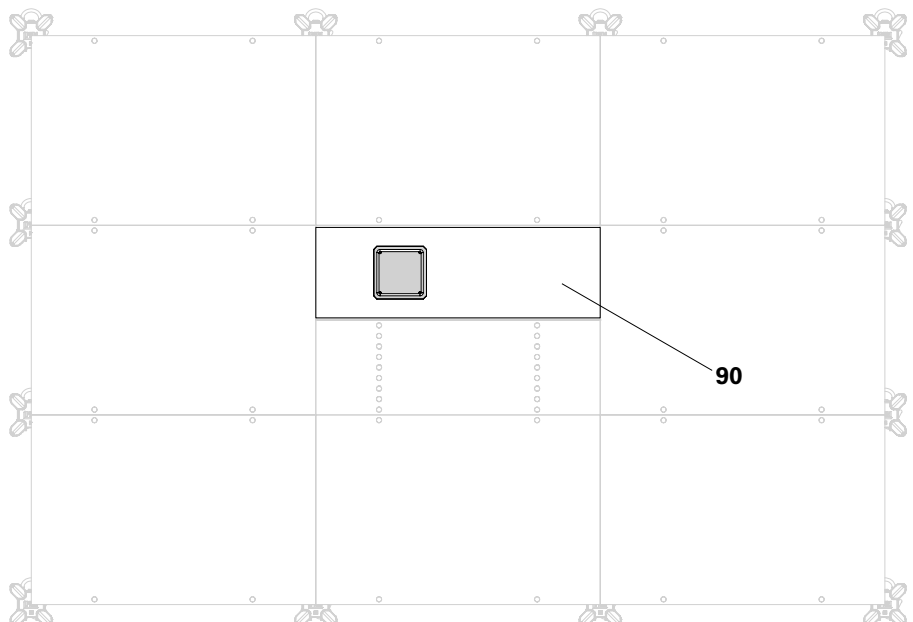

Fig. D3.09

## Backpropped slab - compensations around columns



### Warning

Unsecured components may topple over or collapse!

Toppling or falling components can cause serious injuries.

- ⇒ Continuously close and secure the compensation area with filler plates.
- ⇒ Every DP panel must be supported in the corners by at least four slab props with propheads.
- ⇒ Secure filler plates with nails in order to prevent movement!

Compensations around columns for slab formwork with the DBH backpropping head (42) are carried out along similar lines to slab formwork with DFH propheads (31).

1. Use backpropping heads (42) instead of DFH propheads.
2. Hook DP panels with filler supports on both sides in the compensation areas on props with backpropping heads. (Fig. D3.10)
3. Insert square timber (91) in every possible position in the 18 DFS filler support (16).
4. From below, screw the square timber into place through the screw holes provided in the filler support using Torx 5 x 15 screws.
5. Hook DFP filler panels (17) on backpropping heads from above. (Fig. D3.11)
6. Continuously fill the compensation area with 18 mm filler plates (90), and secure on the timber from the top with nails. (Fig. D3.12)

### Components:

- 
- 12** DP panel / DMP multi panel
  - 16** 18 DFS filler support
  - 17** DFP filler panel
  - 42** DBH backpropping head
  - 90** Filler plate
  - 91** Square timber
- 

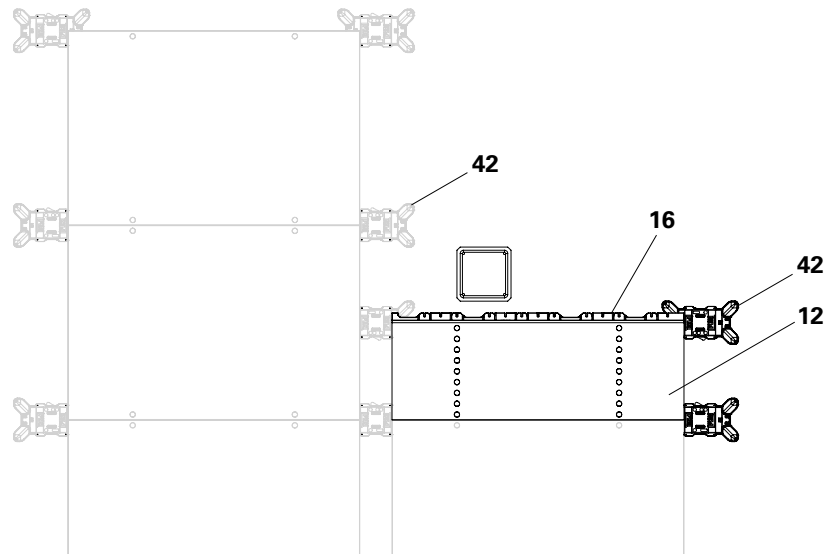

Fig. D3.10

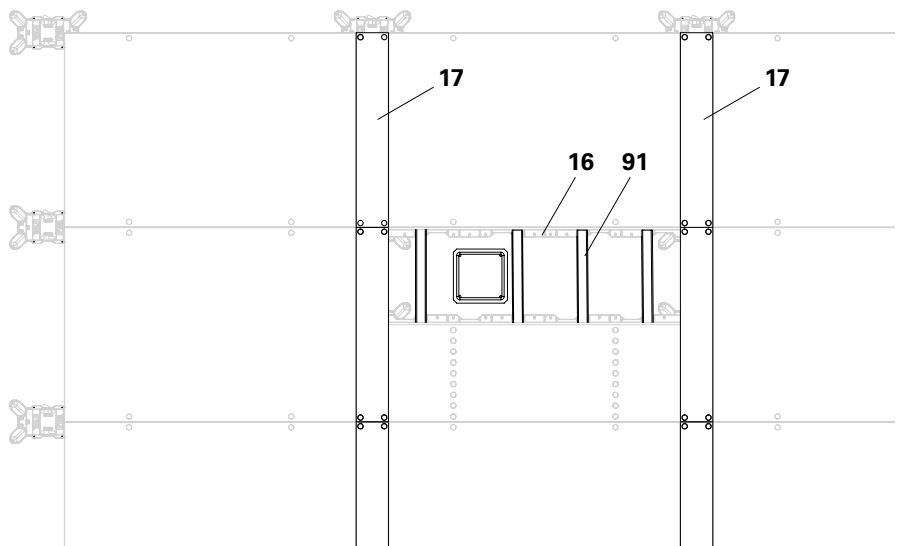

Fig. D3.11

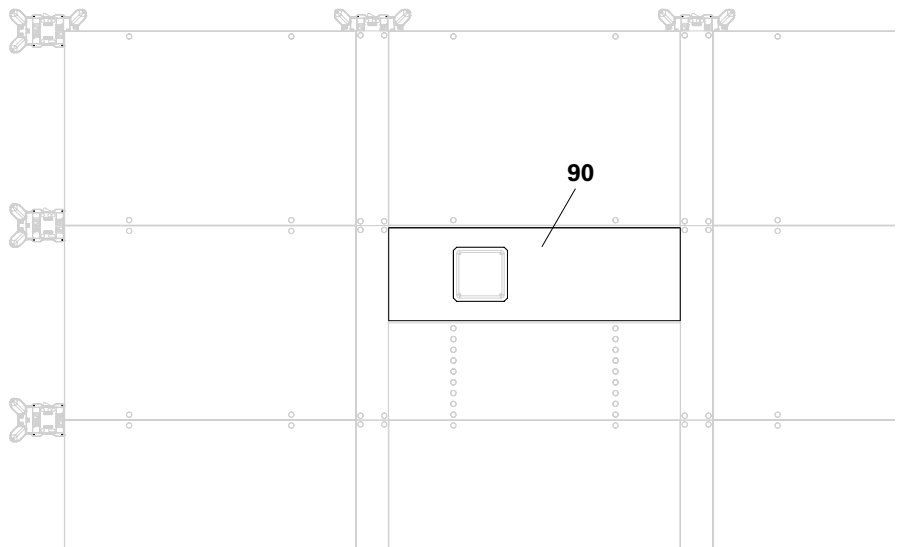

Fig. D3.12

## Cantilevers with DFH pro-heads



### Warning

Slab formwork can collapse if assembly is not complete!

A fall can result in serious injury.

⇒ Do not access the slab formwork before it has been horizontally anchored, the guardrails have been mounted and the cantilevers braced in a form-fit manner.

⇒ Every panel must be supported in the corners by at least four slab props.

### Preparation

Install compensation panels with narrower widths in order to establish the appropriate dimensions for the cantilever. Only DP 135 panels (**10**) are to be installed for the cantilevers.

Brace every DP panel.

The maximum cantilever is 60 cm, see (Fig. D4.04).

Fit the DUO brace connector (**27**) onto every cantilevered DP panel.

Use the inside connection point (**10.3**) on the opposite side of the cantilever. The bolt of the DUO brace connector (**27**) must point away from the cantilever.

(Fig. D4.01 + Fig. D4.01a)

For transversely-positioned main fields, erect additional props across the width of the cantilevered DP panels.

Fit DUO slab guardrail holders (**74**) and SGP guardrail posts (**75**). Maximum width of influence 1.80 m.

### Installation

1. Attach DP panels (**10**) together with the DUO brace connector (**27**) to the slab prop with DFH prophead (**31**). (Fig. D4.02)
2. Insert the DUO slab guardrail holder (**74**) with the flat side facing down through the connector pocket (**10.2**) of the DP panel. (Fig. D4.02a)

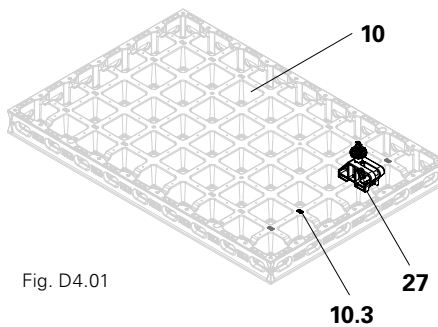

Fig. D4.01

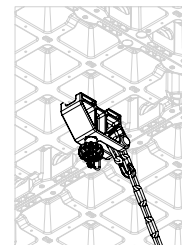

Fig. D4.01a

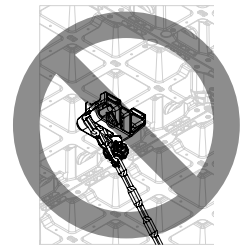

Fig. D4.01b

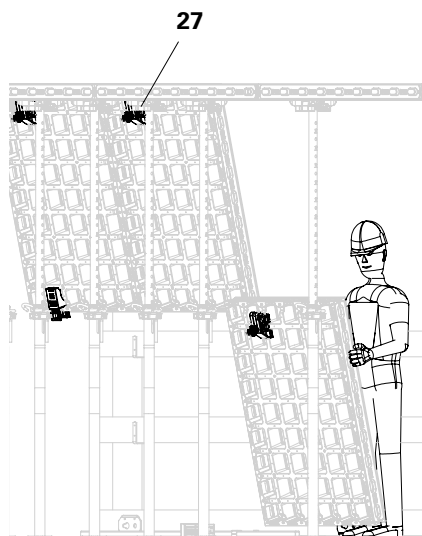

Fig. D4.02

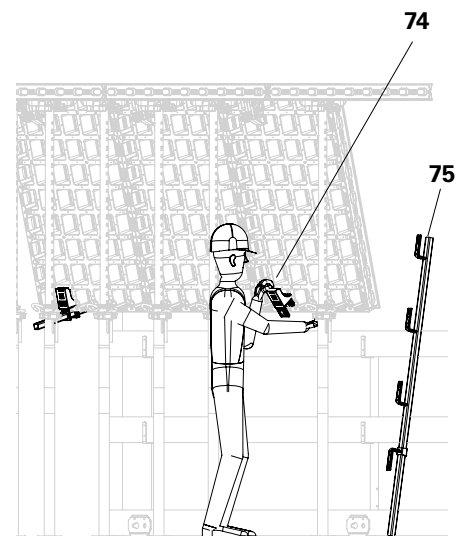

Fig. D4.02a

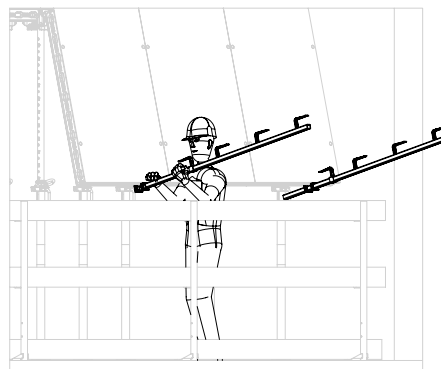

Fig. D4.03

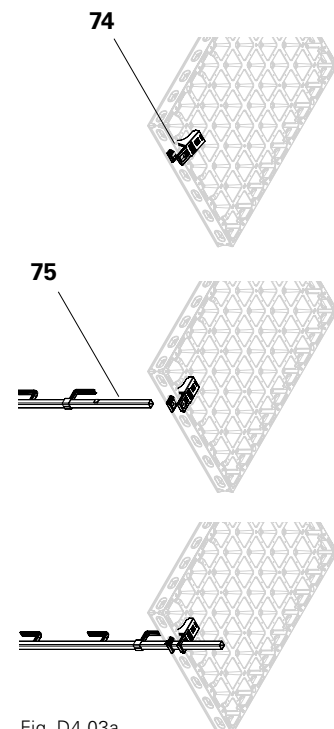

Fig. D4.03a



If space is restricted, hinge, pre-assemble and push up one DP panel after the other.

3. Insert the SGP guardrail post (75) into the square opening of the DUO slab guardrail holder. (Fig. D4.03 + Fig. D4.03a)
4. Place the DUO shuttering aid beside the guardrail holder and push the DP panel up (10). Set the DP panel down on the DUO shuttering aid.
5. Support the cantilever using a slab prop with a DFH prophead (32). Position the slab prop outwards as far as possible. Note: The maximum permissible cantilever is 60 cm! (Fig. D4.04)  
Remove the shuttering aid.
6. Repeat steps 1 to 5 until the cantilever is complete.

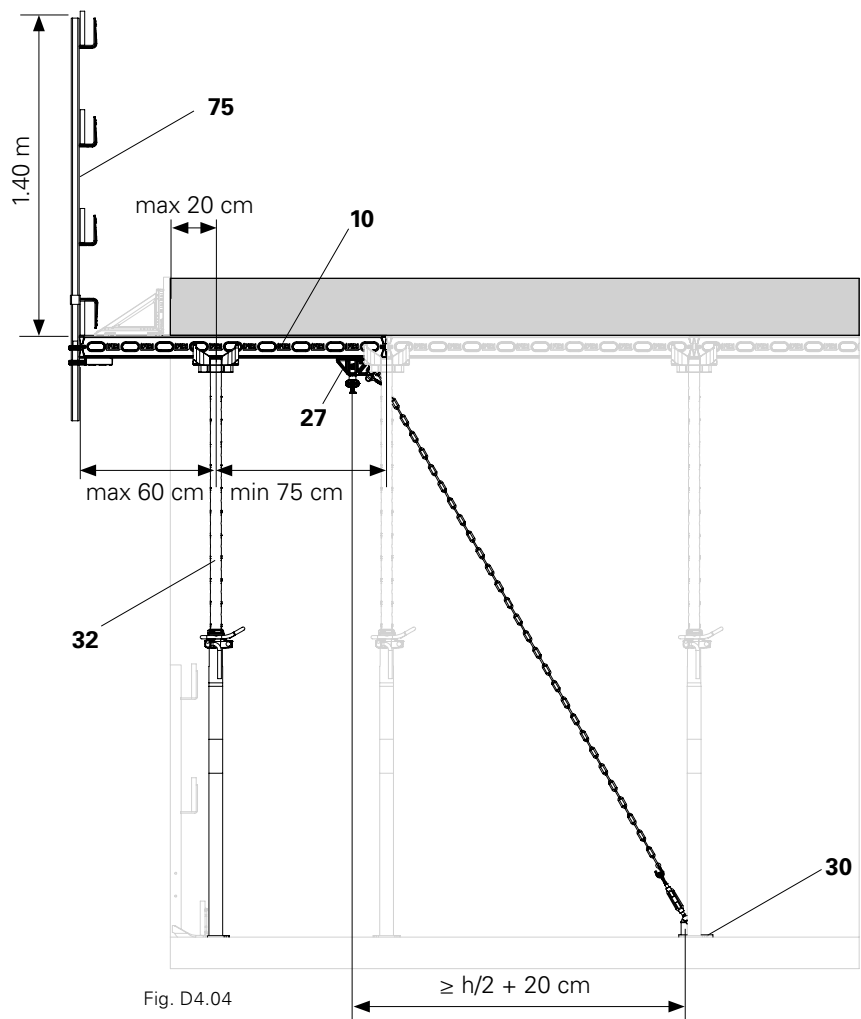

Fig. D4.04

### Bracing the slab formwork

1. Mount the base plate (30) as the lower tie point, e.g. with the PERI 14/20 x 130 anchor bolt. (Fig. D4.04)
2. Hook the chain on the bolt of the DUO brace connector (27).
3. Hook the end of the chain onto the base plate.
4. Pre-tighten the chain with a turnbuckle. Permissible tension force 3 kN. (Fig. D4.04)

### Guardrail boards

#### Warning

During assembly, there is no side protection at the level of the formlining side!

A fall can result in serious injury.

⇒ When standing on the slab formwork without complete guardrails, measures have to be taken to prevent falls, e.g. PPE.

### Installation

1. Take appropriate measures to prevent falls.
2. Insert the guardrail boards (59) and secure with nails. (Fig. D4.05)



Wind bracing measures:

In wind speeds > 90 km/h, reduce the spacing between the DUO slab guardrail holders and remove the uppermost guardrail board. Adapt working area accordingly to suit modified guardrail situation.

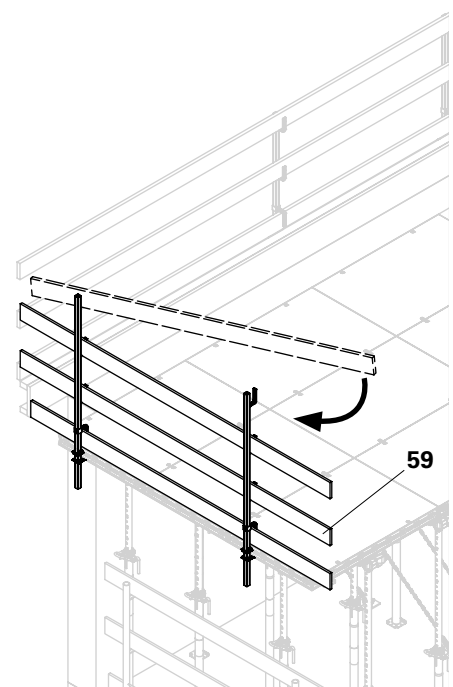

Fig. D4.05

## Cantilevers with DBH backpropping heads



### Warning

Slab formwork can collapse if assembly is not complete!

A fall can result in serious injury.

- ⇒ Do not access the slab formwork before it has been horizontally anchored, the guardrails have been mounted and the cantilevers braced in a form-fit manner.
- ⇒ Every panel must be supported in the corners by at least four slab props.

Carry out preparations as for slab formwork with DFH propheads (31).

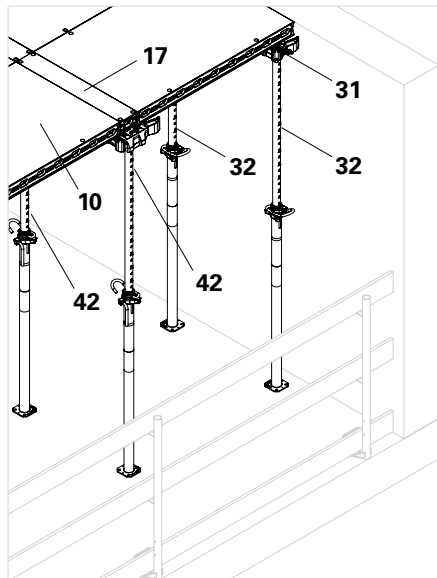

Fig. D4.06

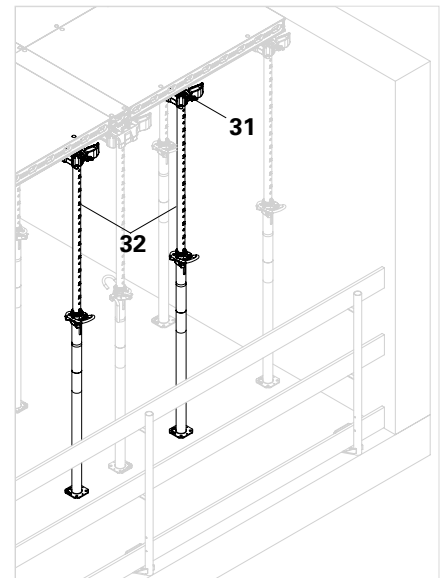

Fig. D4.06a

## Cantilevers in the direction of the main field

1. Push the DP panels (10) complete with mounted SGP guardrail posts (75) and DUO brace connector (27) upwards and support with slab props complete with DFH propheads (32).
2. At the cantilevers, secure each of the DFP filler panels (17) on both adjacent DP panels using 2 DUO couplers (21).
3. Brace the cantilever.
4. Complete installation of the guardrails, see Guardrail boards.

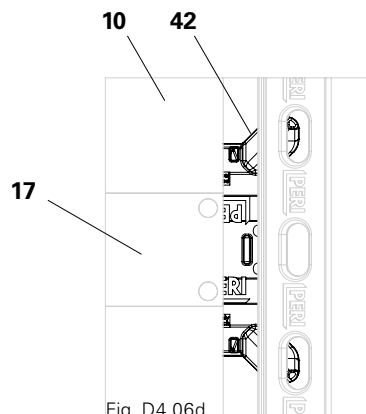

Fig. D4.06d

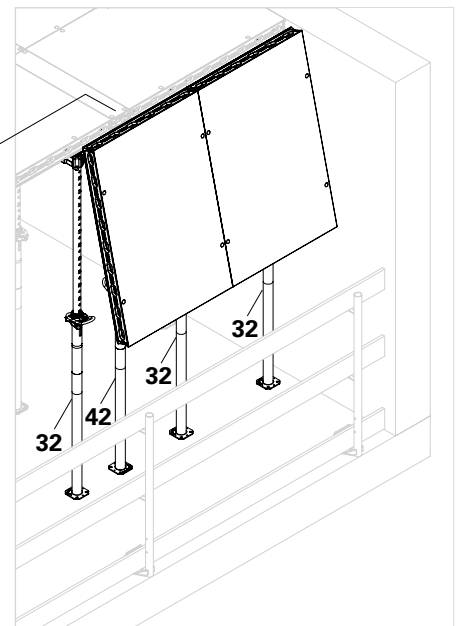

Fig. D4.06b

## Cantilevers installed crosswise to the direction of the main field

1. Erect additional props with the DFH prophead (32) across the width of the cantilevered DP panels (10). (Fig. D4.06a)
2. Attach the DP panels (10) complete with mounted brace connector to the DFH propheads (31) and DBH backpropping heads (42). (Fig. D4.06b + Fig. D4.06d)
3. Mount the SGP guardrail post (75), push the DP panel upwards and support it using the slab prop with DFH prophead (32). (Fig. D4.06c)
4. Brace the cantilever.
5. Complete installation of the guardrails, see Guardrail boards.

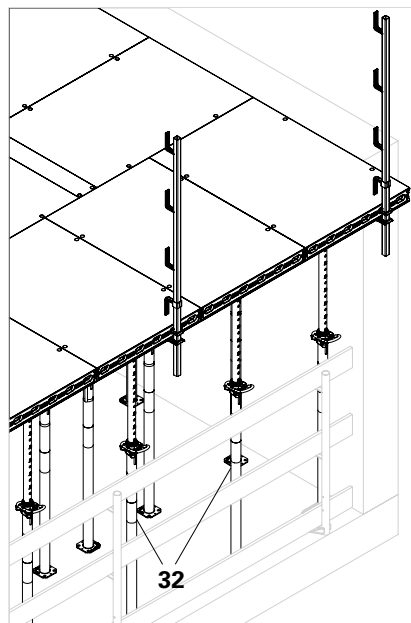

Fig. D4.06c



Do not exceed the maximum permissible cantilever size.  
Brace the cantilever. (Fig. D4.04)

### Components:

- 10 DP panel
- 17 DFP filler panel
- 32 Slab prop with DFH prophead
- 42 DBH backpropping head

## Alternative



### Warning

Slab formwork can collapse if assembly is not complete!

A fall can result in serious injury.

- ⇒ Do not access the slab formwork before it has been horizontally anchored, the guardrails have been mounted and the cantilevers braced in a form-fit manner.
- ⇒ Every panel must be supported in the corners by at least four slab props.

As an alternative to the DUO brace connector (27) with bracing chains, DUO couplers (21) can be mounted to prevent the formwork from tilting.

This is possible if every panel joint:

- is aligned parallel to the open slab edge and
  - in the area of 2.7 m from the slab edge, each DP panel is connected on the short and long joints using 1 DUO coupler (21).
- (Fig. D4.07)

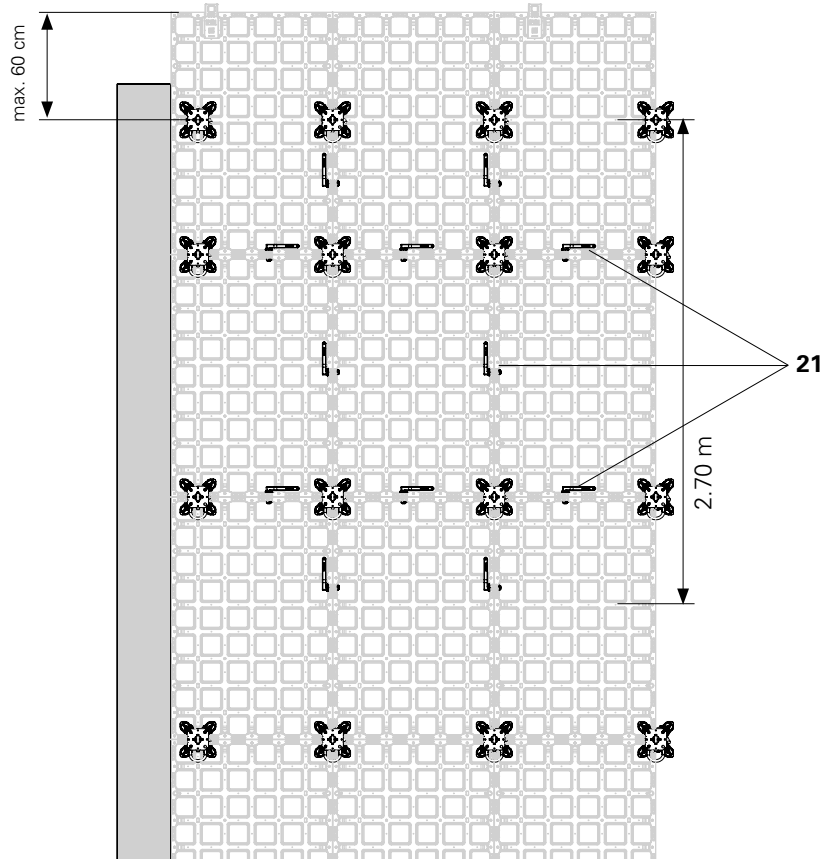

Fig. D4.07



## Warning

During the striking process, there is either no side protection or limited side protection at the level of the formlining side!

A fall can result in serious injury.

- ⇒ Retract components only when the concrete has sufficiently hardened and the person in charge has given the go-ahead for striking to take place.
- ⇒ When standing on the slab without complete guardrails, measures have to be taken to prevent falls.
- ⇒ Remove the DUO wall holder only when dismantling the panel which is directly connected to it!



- Firstly, remove all attachment parts such as guardrail boards, braces and DUO couplers (21) which are attached to the DP panels to be dismantled.
- Remove the DP panels (10) individually, one after the other.
- Start striking at the DP panel that was mounted last.

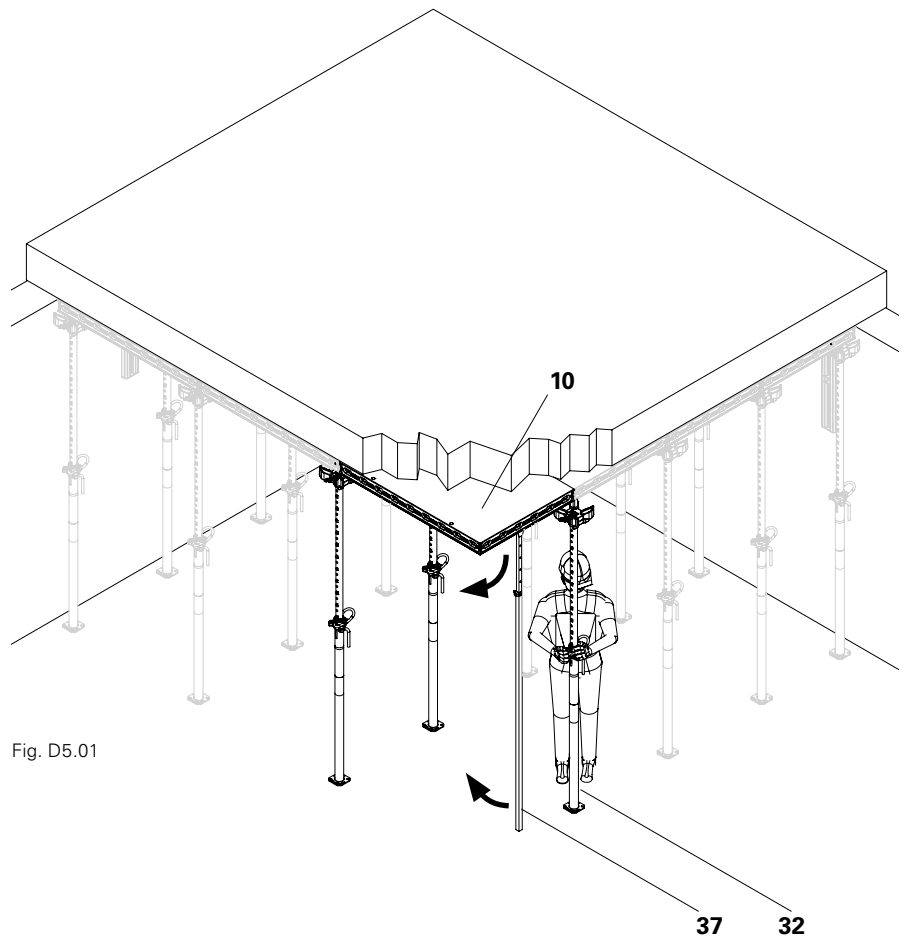

Fig. D5.01

## DFH system propheads

### Striking and dismantling

1. Take measures to prevent falls and remove the guardrail boards from all SGP guardrail posts.
2. Remove DUO couplers (21) before lowering the slab props.
3. Insert both flanges (37.1) of the DUO shuttering aid (37) into the connector pockets of the DP panel.
4. Lower four slab props of the first DP panel by max. 2 cm.
5. Pull the DP panel down onto the prop with the DFH prophead (32) and set it back down onto the DUO shuttering aid (37).

(Fig. D5.01a + Fig. D5.01b)

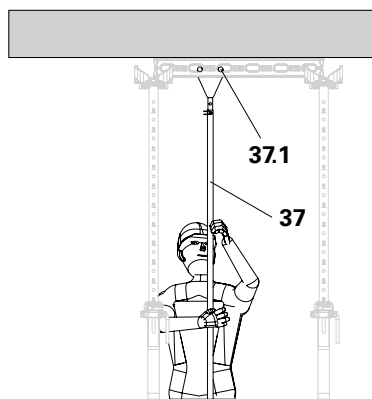

Fig. D5.01a

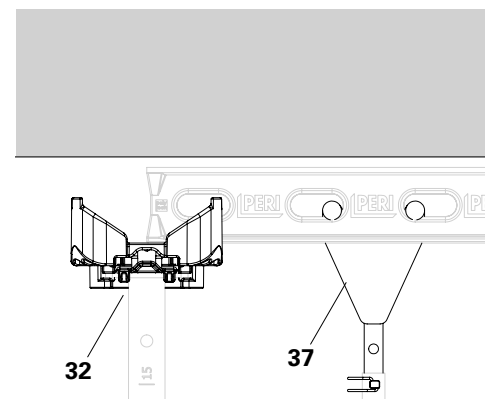

Fig. D5.01b

6. Remove the outside props.
7. Tilt the DP panel (10) downwards with the DUO shuttering aid (37).
8. If mounted, remove the SGP guardrail posts (75), DUO slab guardrail holder (74), chain and DUO brace connector (27).
9. Detach the DP panel (10) and take it away for cleaning.  
Repeat steps 2–9. Only lower the slab props that directly support the DP panels to be removed in each case.

## DBH system backpropping heads

Compared to the system with the DFH prophead, the system with filler panels and backpropping head allows striking to take place earlier.

To do so, slab props are inserted into the prop support in the centre of the filler panel.

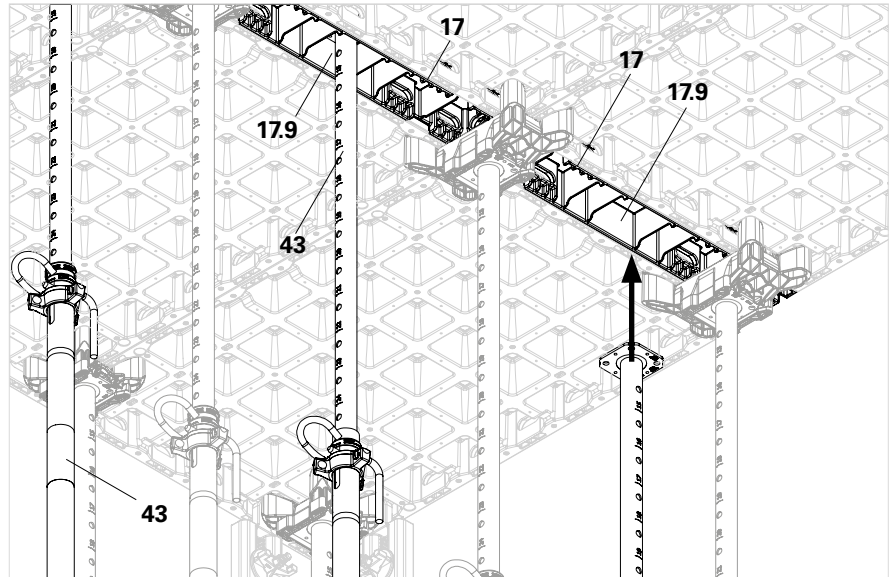

Fig. D5.02

## Striking and dismantling

1. Take measures to prevent falls and remove the guardrail boards from all SGP guardrail posts (75).
2. Position two slab props without propheads (43) in the prop supports (17.9) in the centre of two filler panels (17) that have been installed next to each other.  
(Fig. D5.02 + Fig. D5.02a)
3. Remove DUO couplers (21) before lowering the slab props.
4. Insert both flanges of the DUO shuttering aid (37) into the connector pockets of the first DP panel.
5. Lower four slab props of the first DP panel by max. 2 cm.

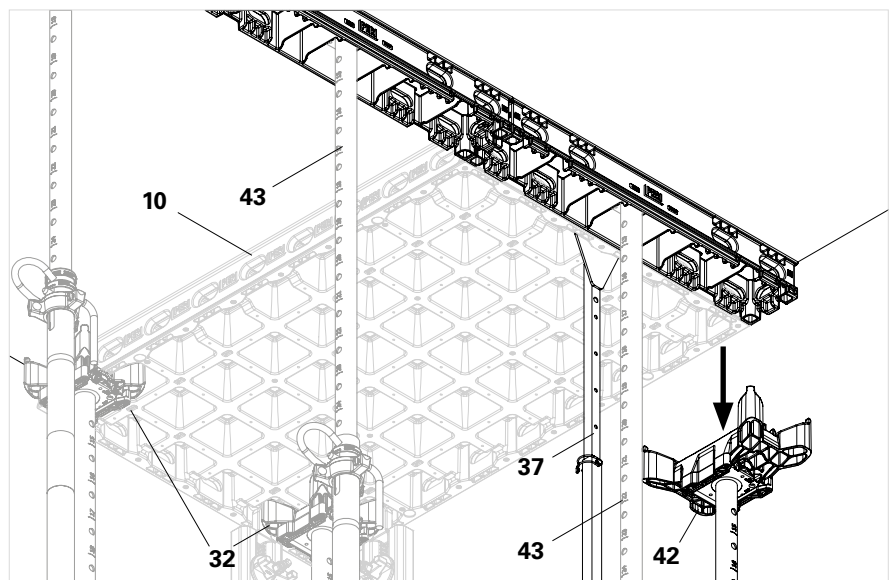

Fig. D5.02a

6. Pull the DP panel down onto the backpropping head and prop it up again on the DUO shuttering aid (37).  
(Fig. D4.01a + Fig. D4.01b)
  7. Remove the outermost props (43) and therefore support other DFP filler panels (17) without propheads.  
(Fig. D5.03)
  8. Tilt the DP panel (10) downwards with the DUO shuttering aid (37).
  9. If mounted, remove the SGP guardrail posts (75), DUO slab guardrail holder (74), chain and DUO brace connector (27).
- Repeat steps 2 - 9. Only lower the slab props that directly support the DP panel (10) to be removed in each case.

### Components:

- 10 DP panel
- 17 DFP filler panel
- 17.9 Prop support
- 32 Slab prop with DFH prophead
- 37 DUO shuttering aid
- 42 DBH backpropping head
- 43 Slab prop

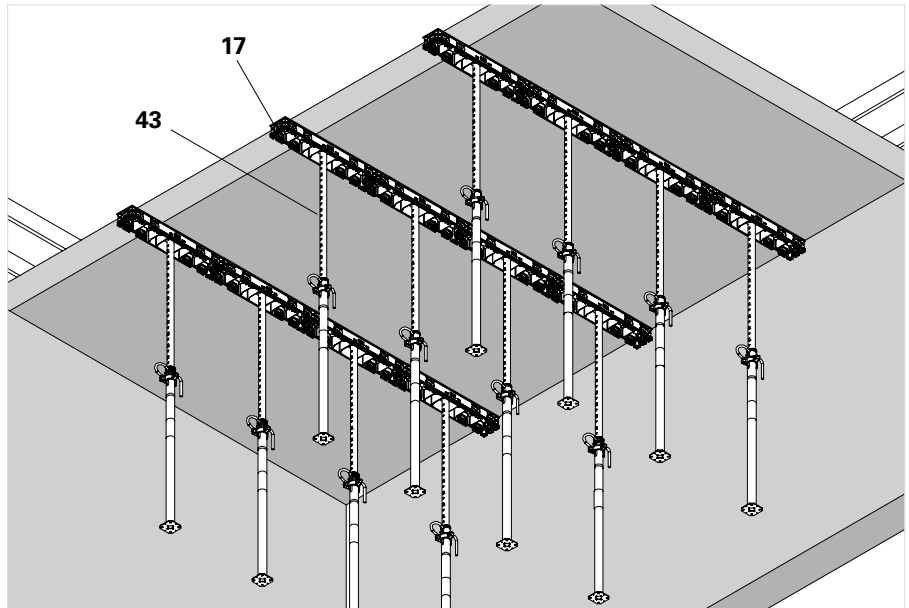

Fig. D5.03

### Step-by-step dismantling

The filler panels are not coupled to each other. As a result, additional slab props and filler panels can be removed with increasing component strength.  
(Fig. D5.04)

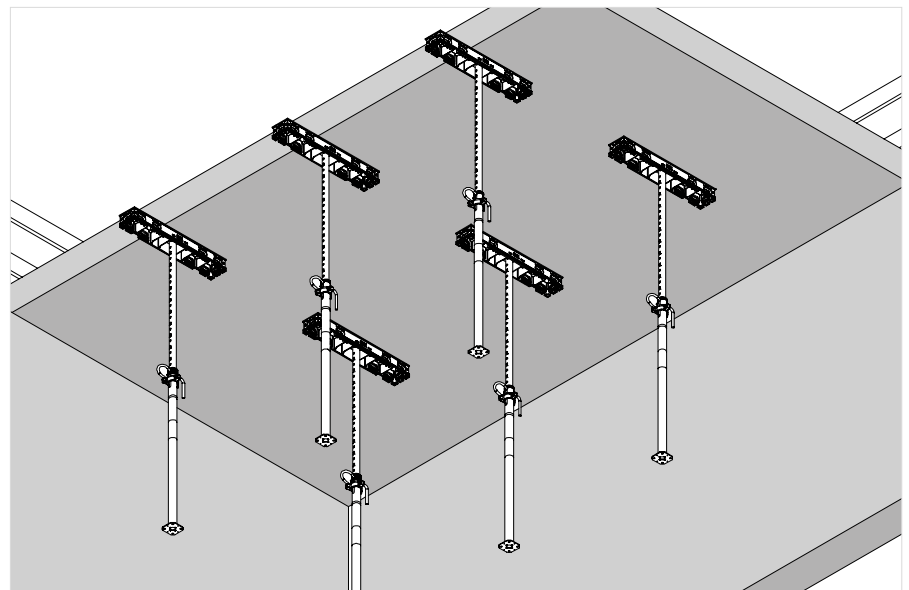

Fig. D5.04

## Additional system components

**VT 20 L = 3.60 m maximum slab thickness: 20 cm for row 6**

**VT 20 L = 2.65 m maximum slab thickness: 30 cm for row 6**

The DUO carrier rack (**83**) is an adapter for conventional carriers that is available in two lengths, the 1305 mm end piece (**83a**) and 900 mm middle piece (**83b**).

The special feature of the adapter is that it can be used with the PERI carriers VT 20 (**35**), GT 24 (**35.1**) and all other nailable carriers with a belt width of 80 mm.

(Fig. D6.01 + Fig. D6.02)

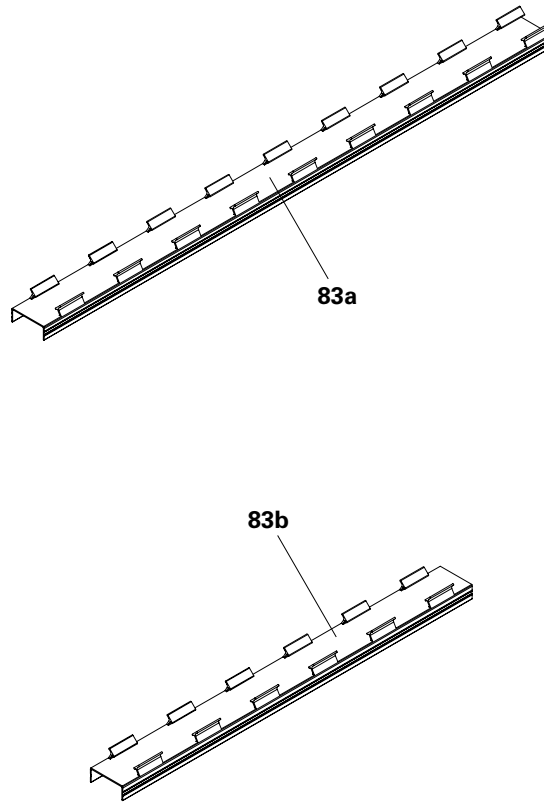

Fig. D6.01

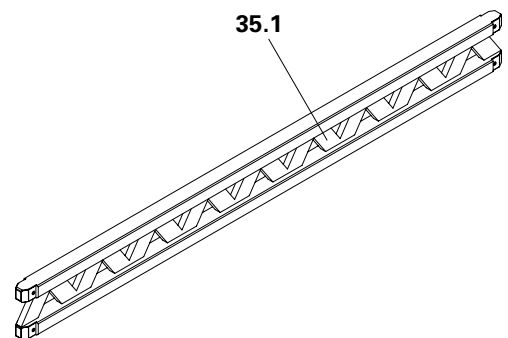
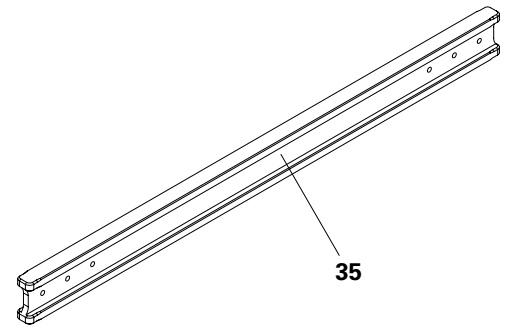

Fig. D6.02

# D6 Slab formwork with DUO carrier racks

## Installation on PERI carriers VT 20 and GT 24 with length = 3.60 m or 2.65 m

(For simplification purposes, the illustrations only show the VT 20 carrier)

The DUO carrier rack (**83**) is placed on the VT 20 (or GT 24). The specified edge distances (see section D6, Slab formwork with DUO carrier racks, subsection "Reference dimensions for mounting the DUO carrier rack on the girder") must be taken into account so that the teeth of the DUO carrier rack fit into the DUO panel corners.

(Fig. D6.05 + Fig. D6.06)

Place two carrier rack end pieces (**83a**) (length = 1305 mm) on each end of the VT 20 L = 3.60 m (**35**). Place a carrier rack middle piece (**83b**) (length = 900 mm) in the centre, between the end pieces.

For the shorter version, VT 20 L = 2.65 m, two carrier rack end pieces (**83a**) (length = 1305 mm) will be sufficient for covering the entire length.

Fix the DUO carrier rack (**83**) to the girder from the side or from above using either nails or screws.

(Fig. D6.03+ Fig. D6.04)

Preferred position for nails or screws (**a**).

(Fig. D6.04)

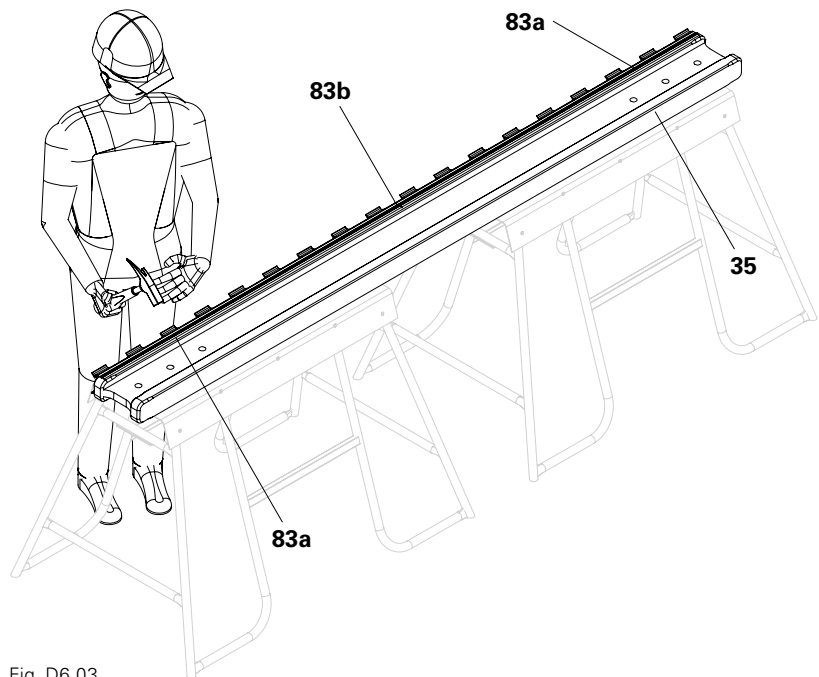

Fig. D6.03

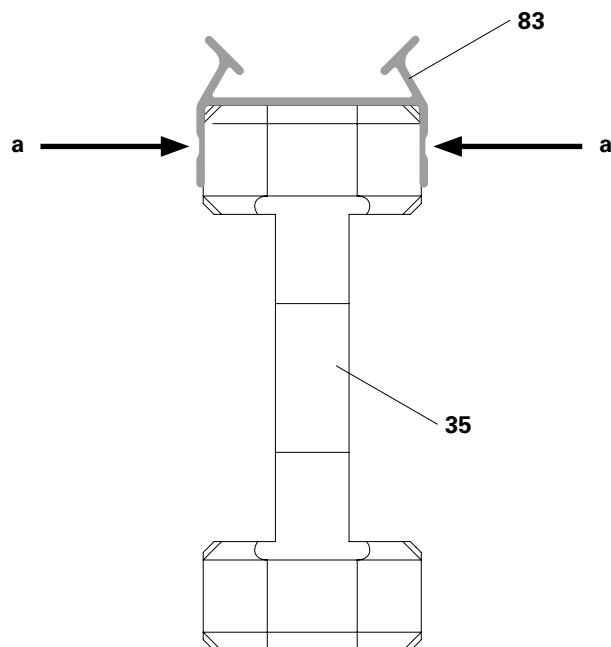

Fig. D6.04

## Reference dimensions for mounting the DUO carrier rack on the girder



Fit the carrier rack end pieces (**83a**) with the "outermost teeth" towards the edges.  
(Fig. D6.05 + Fig. D6.06)

**VT 20 L = 3.60 m**

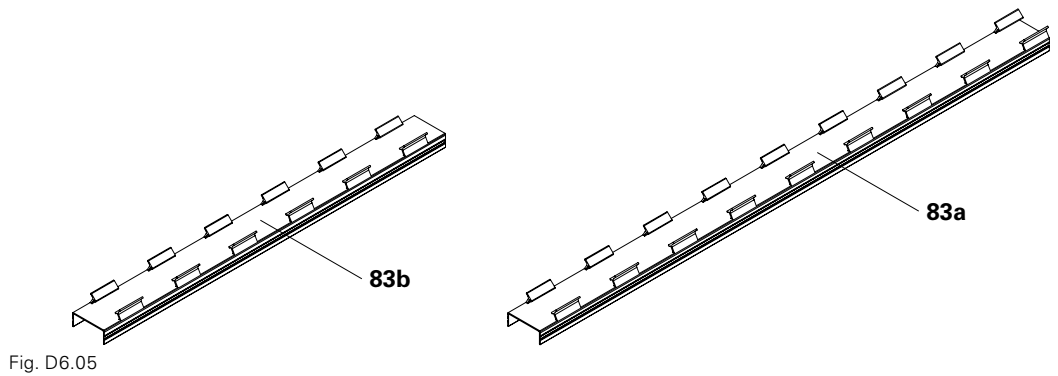
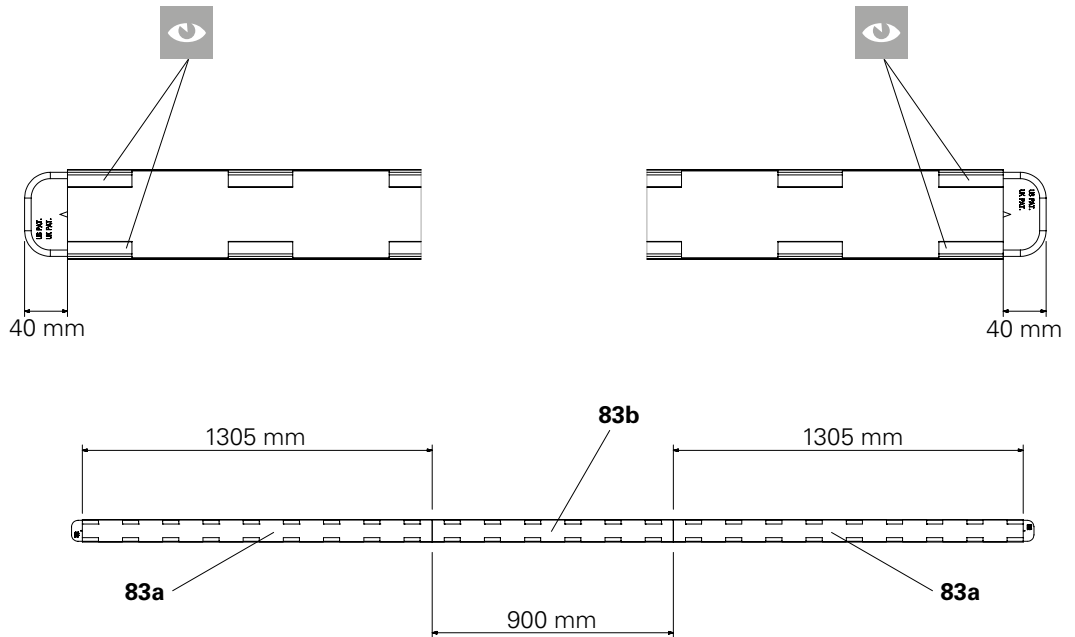

Fig. D6.05

**VT 20 L = 2.65 m**

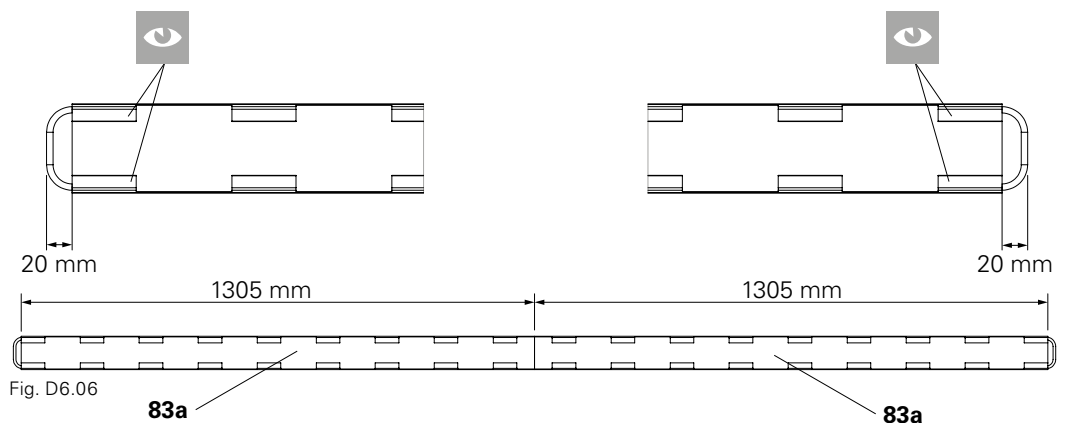

Fig. D6.06

## Shuttering



### Warning

- Loose components that are present during assembly may fall down! Falling components can cause serious injuries.
  - ⇒ Wear a safety helmet.
  - ⇒ Wear safety shoes.
  - ⇒ Wear safety gloves.
- Components may topple over or fall down in high winds! Toppling or falling components can cause serious injuries.
  - ⇒ Larger panel units are to be formed with wind speeds of 26 km/h and more. For this, connect panels to each other using DUO couplers, and secure by means of bracing or ballasting.

**Do not start the concreting process in the cantilevered area of the girder!**



Insert the long side of the DP panels parallel to the longer wall of the floor plan. Insert the slab props in such a way that the G hooks can be handled and secured.

Seal the tie points of the DP panels with plugs.

Start shuttering from a corner.

## First row



### Danger

- Working area at a great height!  
Danger to life due to falling!  
→ Mount guardrails before shuttering and according to valid regulations!  
→ Wear personal protective equipment!
- Props can tip over if installed incorrectly!  
Toppling slab formwork poses a risk to life!  
→ Mount guardrails before shuttering and according to valid regulations!  
→ Wear personal protective equipment!

1. Set up two slab props complete with crossheads (**34**) or lowering heads (for simplification purposes, not shown) and secure using tripods (**33**). Set up the first slab prop in the corner with a gap of 15 cm to the front wall, and:

- If VT 20 L is used = 3.60 m
  - Set up the first slab prop with a 0.85 m gap to the front wall and the second slab prop at a distance of 2.20 m from the first. (Fig. D6.07)

- If VT 20 L is used = 2.65 m
  - Set up the first slab prop with a 0.775 m gap to the front wall and the second slab prop at a distance of 1.45 m from the first (Fig. D6.08).

2. From below, place the girder on the slab prop using the GT/VT assembly bar (Fig. D6.10a). The maximum edge distances depending on the girder are:

- 70 cm for VT 20 L = 3.60 m (**A**) (Fig. D6.09)
- 60 cm for VT 20 L = 2.65 m (**B**) (Fig. D6.10)

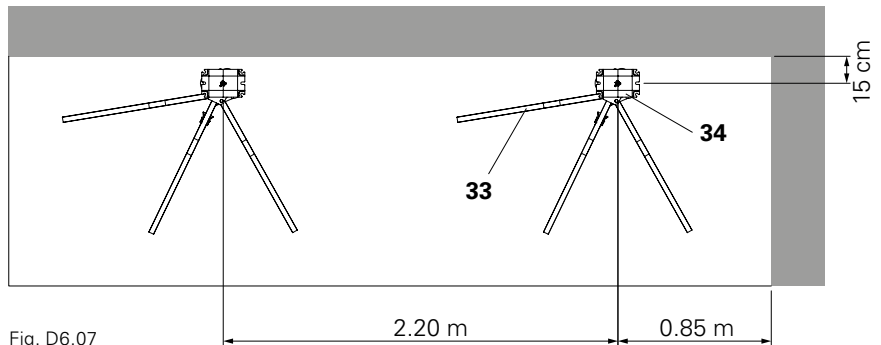

Fig. D6.07

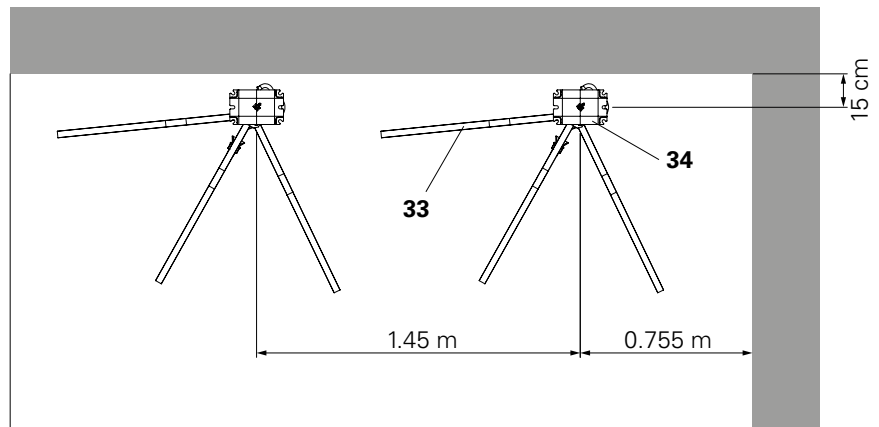

Fig. D6.08

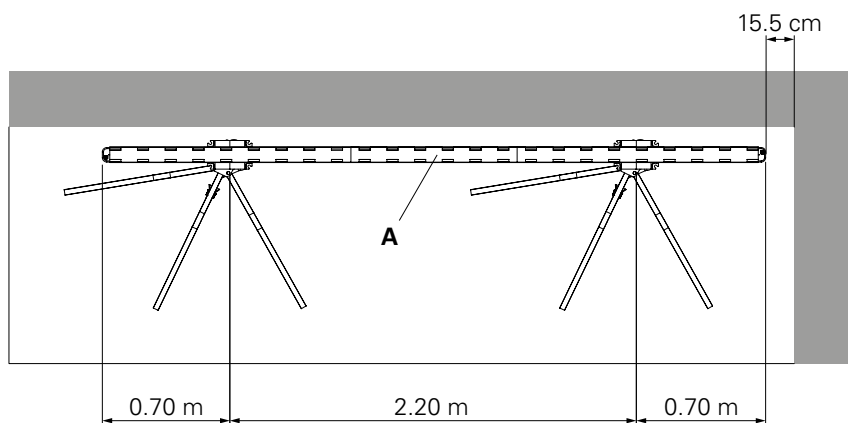

Fig. D6.09

- Place the DP panel (10) in the teeth of the carrier rack.



The DP panel (10) does NOT remain in the teeth of the carrier rack automatically. It must be supported at all times!

- Push the DP panels (10) upwards using the DUO shuttering aid (37) (Fig. D6.11) and leave the DUO shuttering aid standing under the panel. (Fig. D6.12 + Fig. D6.13)



Ensure that the shuttering aid is set to the correct length so that the DP panel (10) is held in a horizontal position. To avoid collisions between the shuttering aid and the next girder, place the shuttering aid (37) within the DP panel (10) (not right at the edge of the panel).

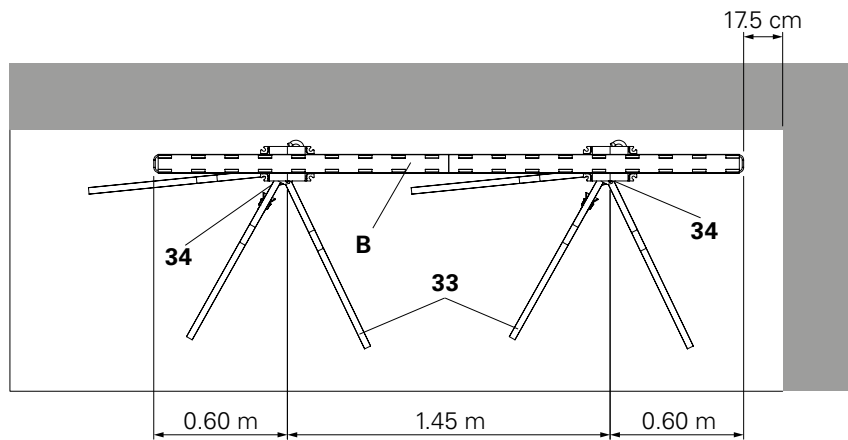

Fig. D6.10

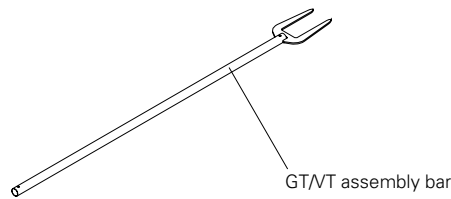

Fig. D6.10a

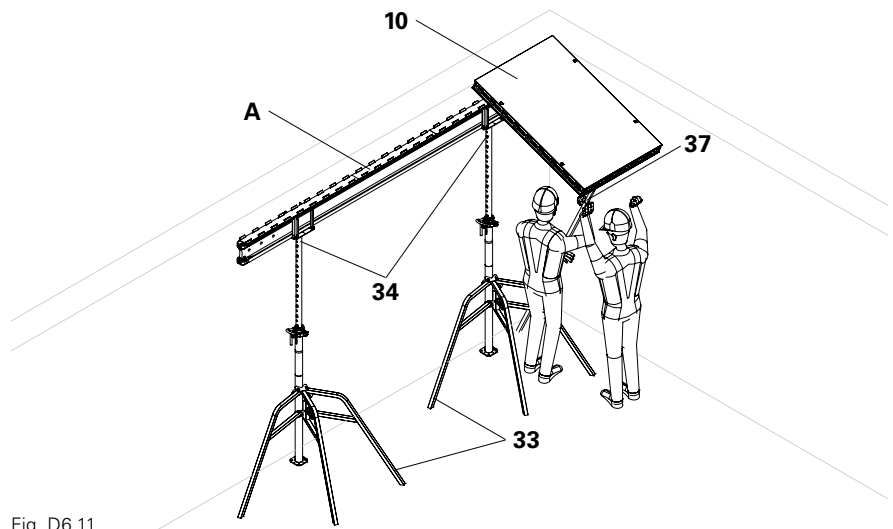

Fig. D6.11

## D6 Slab formwork with DUO carrier racks

- Place four panels (DP 135 x 90) (10) on each VT 20 L = 3.60 m (A).
- Place three panels (DP 135 x 90) (10) on each VT 20 L = 2.65 m (B).

5. Repeat points 3 and 4 for the neighbouring DUO DP panels (10) until the girder is filled with DP panels (10). DP panels (10) that no longer fit onto the current girder are placed on the next girder.

6. Place the second girder (A) and the slab props that support it beneath the edge of the DP panels (10). Adjust the slab props (43) to the correct height. The distance between the first and second row of props must be 1.20 m. The second girder supports the next row of panels. (Fig. D6.14)

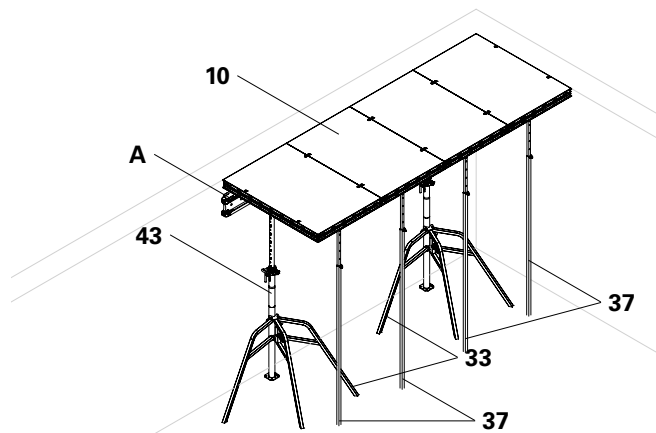

Fig. D6.12

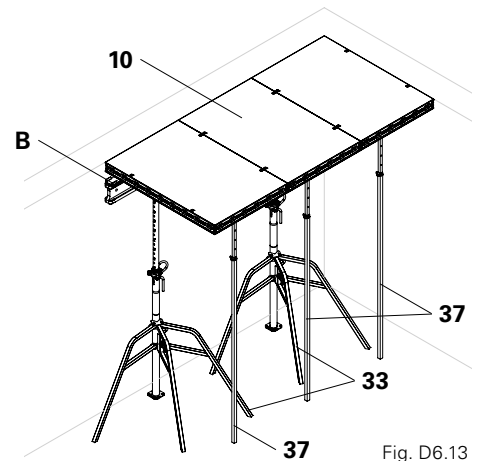

Fig. D6.13

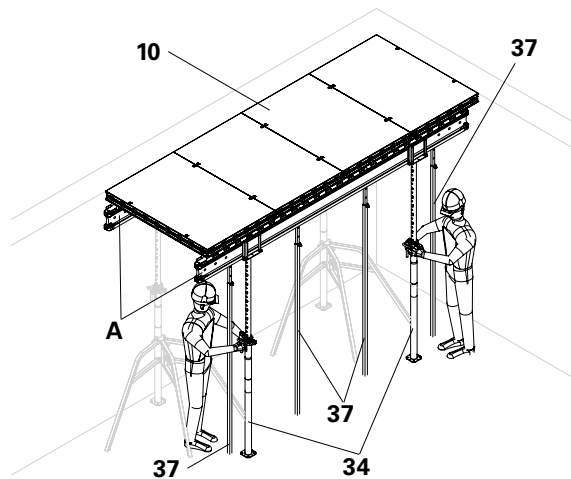

Fig. D6.14

7. Before starting work on the next row, fit one DUO coupler (21) at each panel transition in order to guarantee the overall stability of the system.

8. Push the next DP panel (10) upwards with the DUO shuttering aid (37). (Fig. D6.16)

Connect the DP panel (10) with the DUO coupler (21) at the adjacent DP panel (10). (Fig. D6.15)

9. Place the next girder (35) right next to the previous girder in order to support the DP panel (10). Adjust the height of the slab props (43). Arrange the girders so they are flush with the previous girder rather than laterally offset. (Fig. D6.17)



Ensure that the DP panels (10) fit precisely on the DUO carrier rack (83). The teeth of the DUO carrier rack (83) must support every connector pocket.

Do not remove the DUO shuttering aid (37).

These instructions apply to every girder used (VT 20 L = 2.65 m or VT 20 L = 3.60 m).

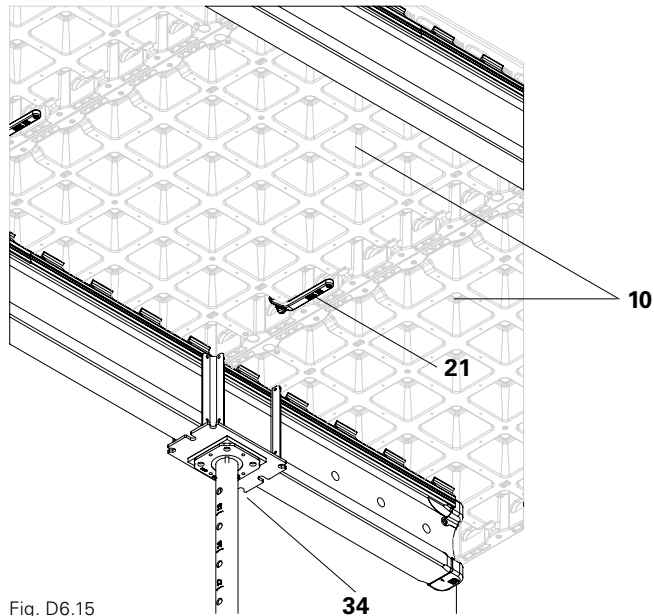

Fig. D6.15

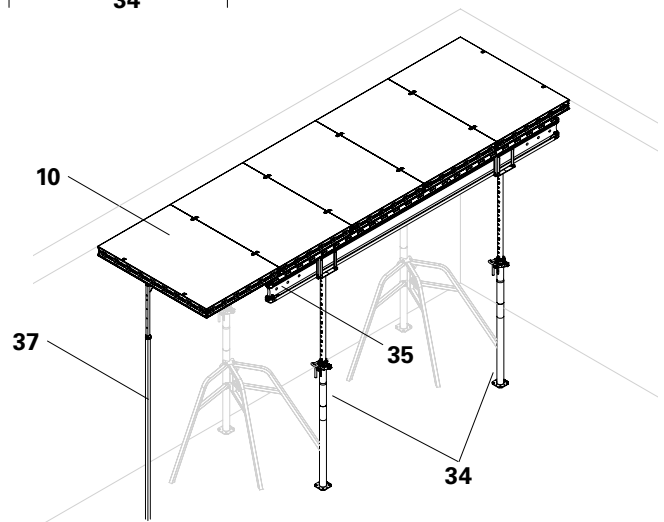

Fig. D6.16

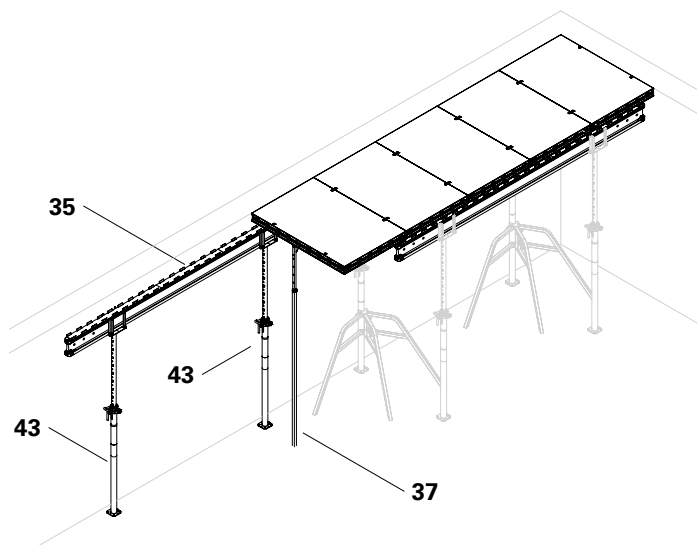

Fig. D6.17

10. Repeat points 3 and 4 for the neighbouring DUO DP panels (10) until the girder is filled with DP panels (10). DP panels (10) that no longer fit onto the current girder are placed on the next girder. (Fig. D6.19)
11. Place the second girder (35) and the slab props (43) that support it beneath the edge of the panels. Adjust the slab props (43) to the correct height. The distance between the first and second row of props is 1.20 m. The second girder supports the next row of panels. (Fig. D6.20)

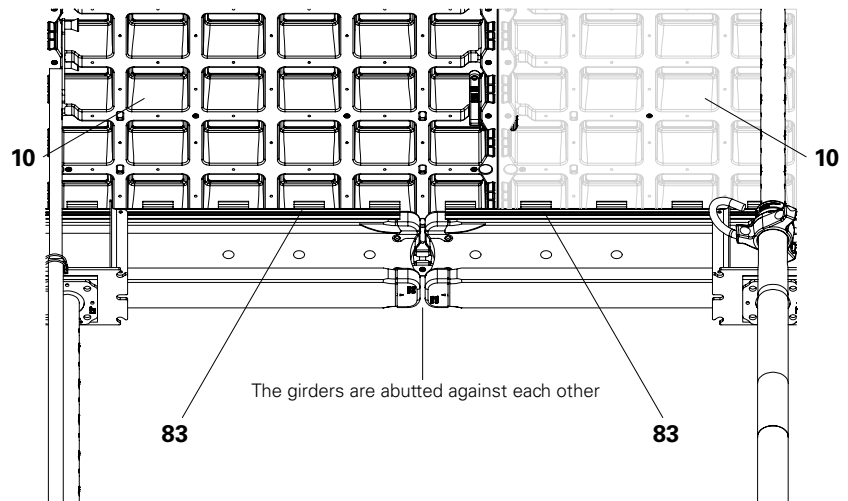

Fig. D6.18

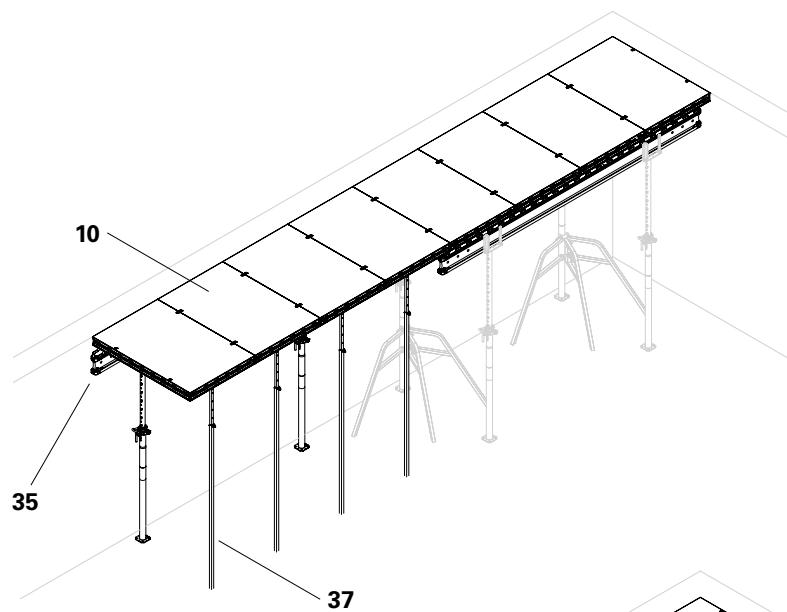

Fig. D6.19

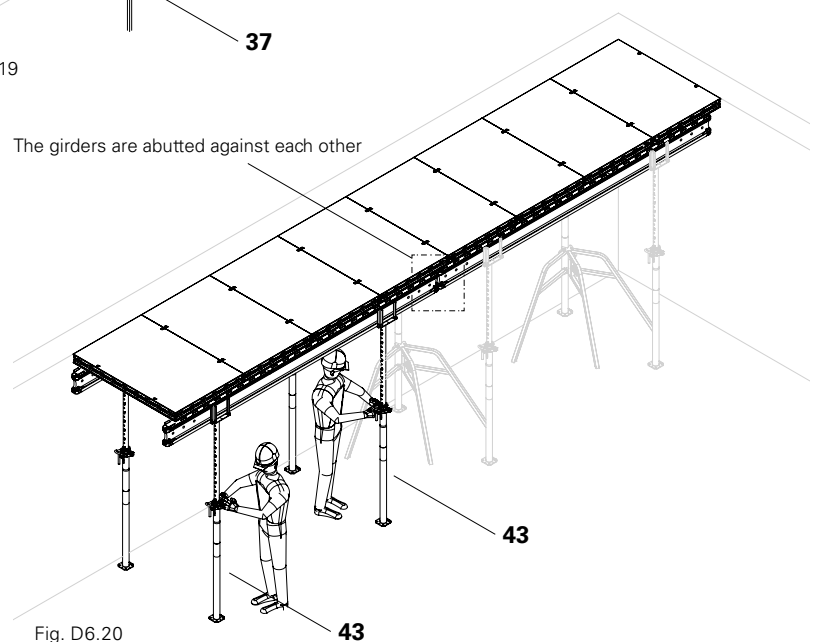

Fig. D6.20

## Second row

Repeat the entire shuttering process used for the first row for the next row of panels.  
(Fig. D6.21)

### VT 20 L = 3.60 m (A) prop spacing

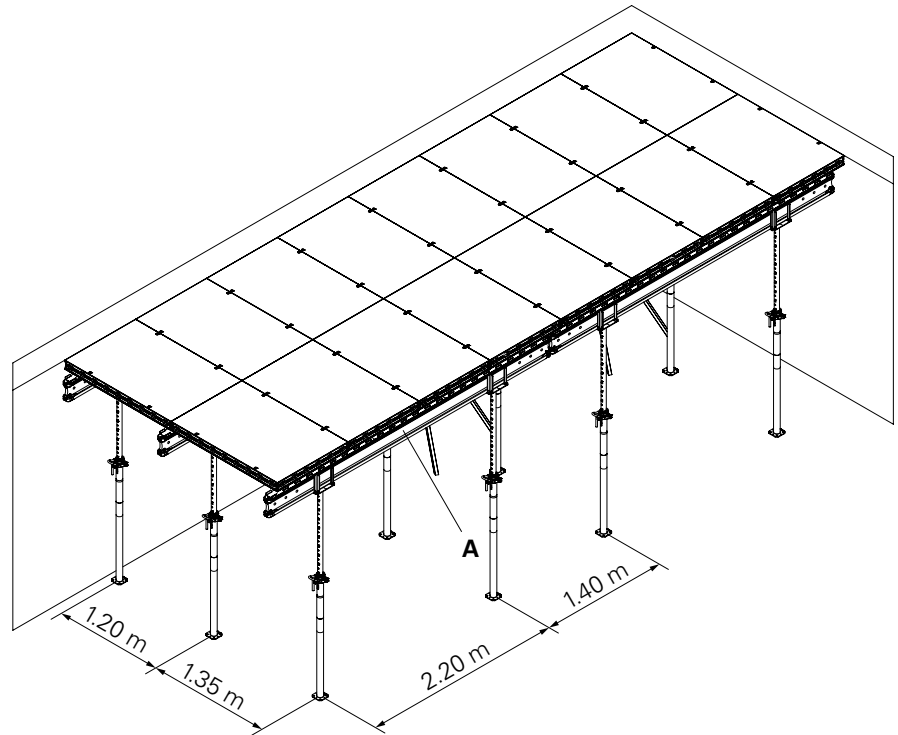

Fig. D6.21

### VT 20 L = 2.65 m (B) prop spacing

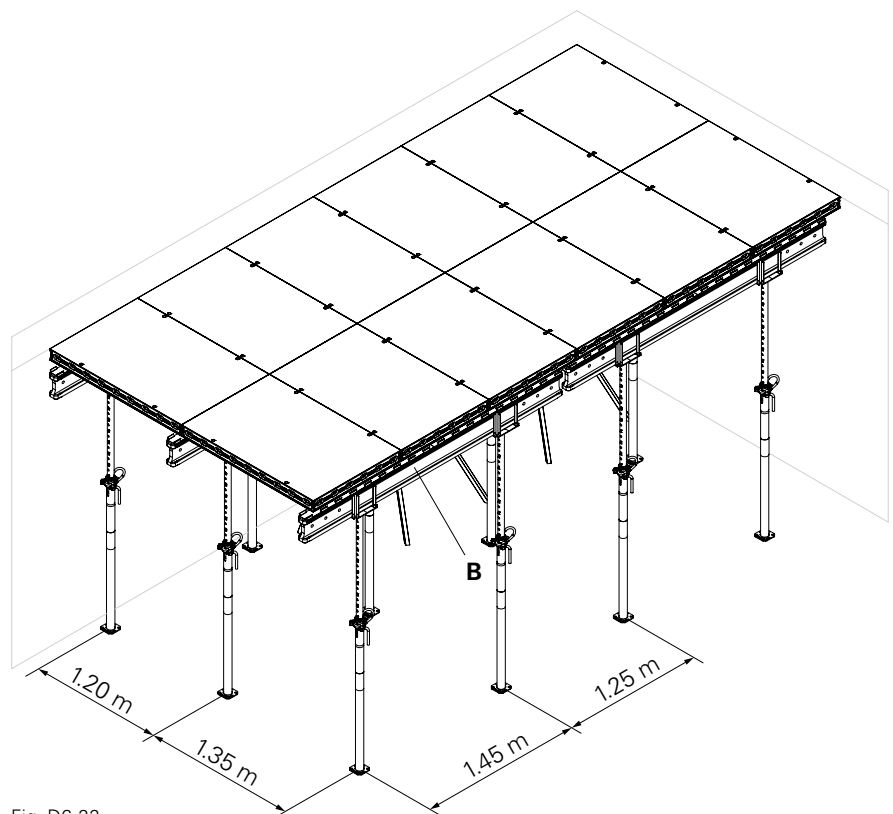

Fig. D6.22

## Striking



### Warning

During the striking process, there is either no side protection or limited side protection at the level of the formlining side!

A fall can result in serious injury.

- ⇒ Retract components only when the concrete has sufficiently hardened and the person in charge has given the go-ahead for striking to take place.
- ⇒ When standing on the slab without complete guardrails, measures have to be taken to prevent falls.



Firstly, remove all attachment parts such as guardrail boards, braces and DUO couplers which are attached to the panels to be dismantled.

- Remove one panel after the other.
- Start striking at the panel that was mounted last.

### Dismantling

1. Take measures to prevent falls and remove the guardrail boards from all SGP guardrail posts.
2. Remove DUO couplers (**21**) before lowering the slab props.
3. Lower the slab props with crosshead (**34**) in the zone by approx. 5 - 6 cm. Use the DUO shuttering aid (**37**) to pull down "sticky" DUO DP panels (**10**). (Fig. D6.23)
4. Before removing a girder, support every panel that is lying on the girder using DUO shuttering aids (**37**). (Fig. D6.24)



Remove the DP panels (**10**) one row at a time, one after the other.

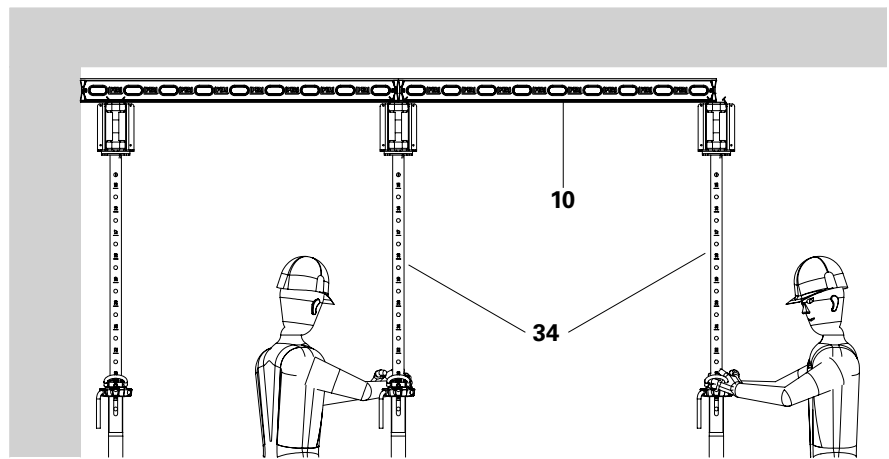

Fig. D6.23

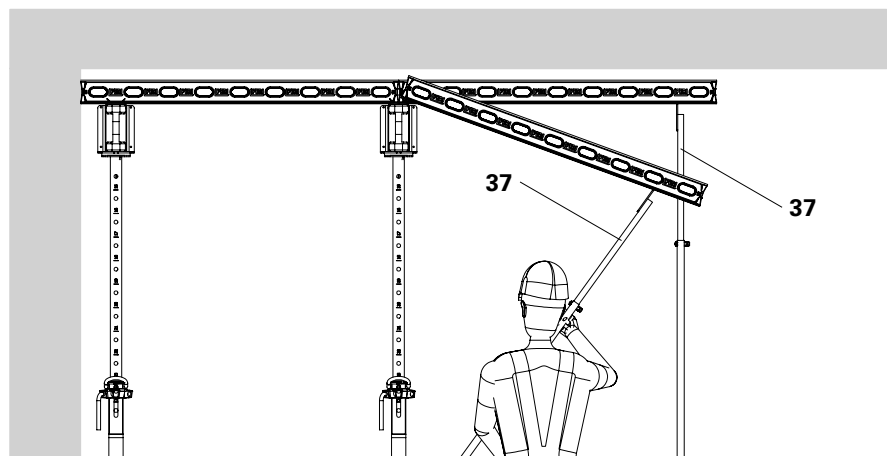

Fig. D6.24



## Foreword

In order to maintain the value and operational readiness of the DUO lightweight system hand-set formwork over a long period of time, the formwork should be carefully handled at all times.



### Caution

Small parts and concrete residue may chip off during cleaning!  
These small splintered parts can cause injuries.

- ⇒ Wear safety goggles.
- ⇒ Wear safety gloves.



Material damage!

- When using high pressure cleaners, do not exceed the maximum water pressure of 200 bar and maximum temperature of 60°C!
- Do not use a hammer! If required, only use the DUO rubber hammer!

### DUO cleaning device

Use the broad side to clean the formlining.  
Use the narrow side to clean the panel frame.

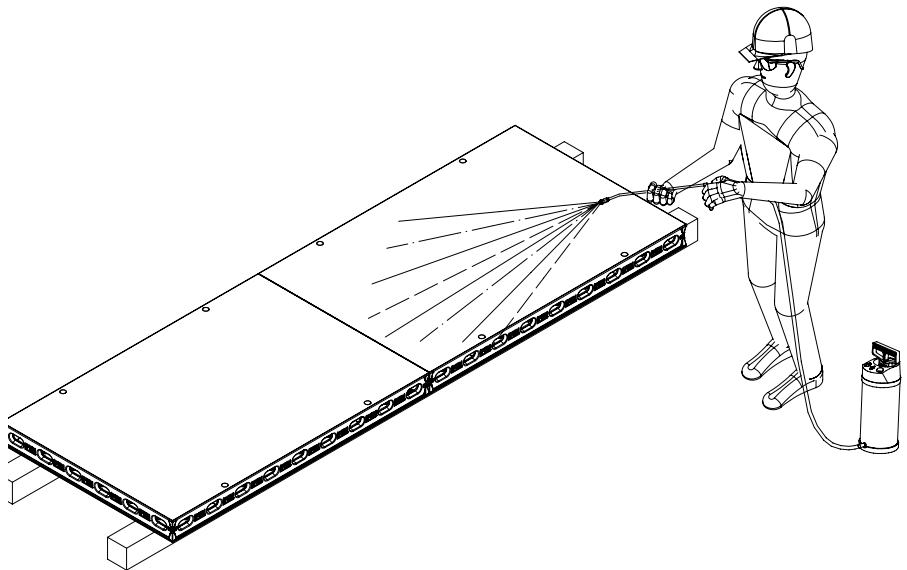

Fig. E1.01

## Cleaning instructions

- There is no chemical reaction between the composite material and concrete. In order to minimise the cleaning effort and reduce the wear of the formlining, spraying all parts with PERI Plasto Clean release agent before every use is recommended; alternatively, using a wax or solvent-based release agent is also possible. (Fig. E1.01)
- Do not use oil (e.g. diesel, kerosene). Observe safety data sheet.
- Directly after striking, clean the panels only with the DUO cleaning device (8) (Fig. E1.02 + Fig. E1.03), a cloth or high pressure cleaner (Fig. E1.04) with water pressure between 100 and 200 bar.
- To fulfil the surface requirements, these can be exchanged. (Fig. E1.05)
- For damage-free transportation, suitable PERI pallets and stacking devices are available, see section A1 Storage and transportation.

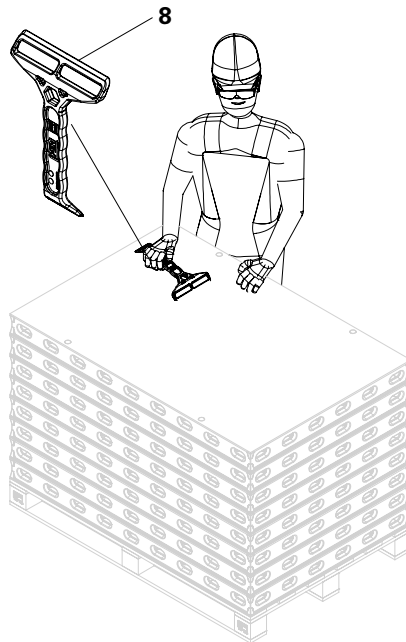

Fig. E1.02

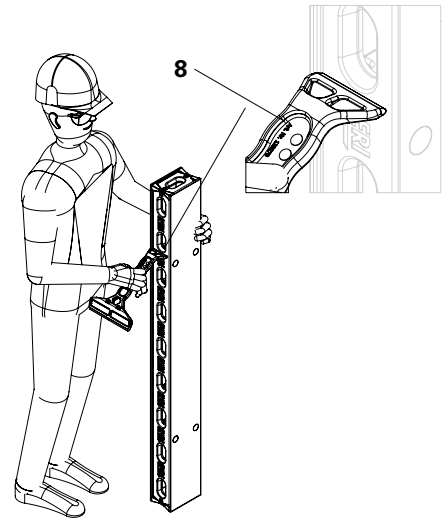

Fig. E1.03

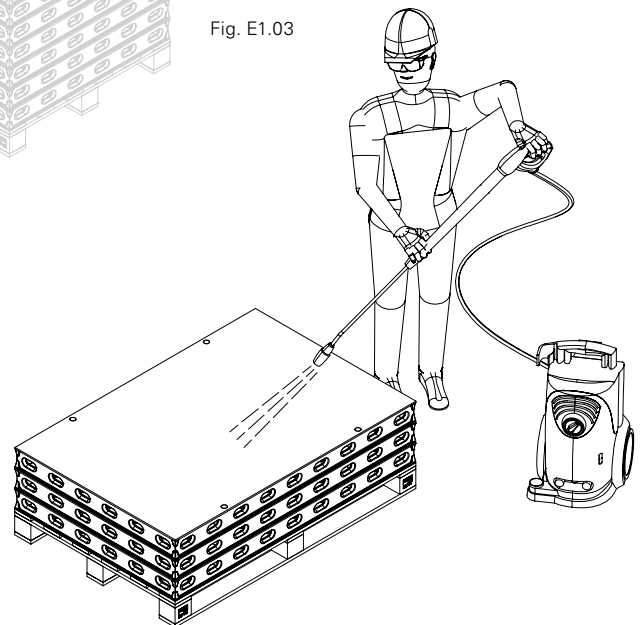

Fig. E1.04

## DUO cleaning device and DUO shuttering aid

Panel units can be cleaned immediately after striking without requiring them to be dismantled or laid flat.

(Fig. E1.05a)

For this, firmly attach the DUO cleaning device (**8**) to the DUO shuttering aid (**37**) by means of M12 x 60 Allen screws and nuts.

(Fig. E1.054)

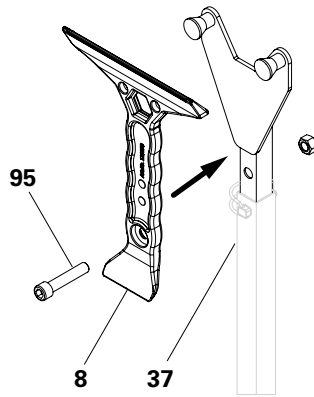

Fig. E1.05

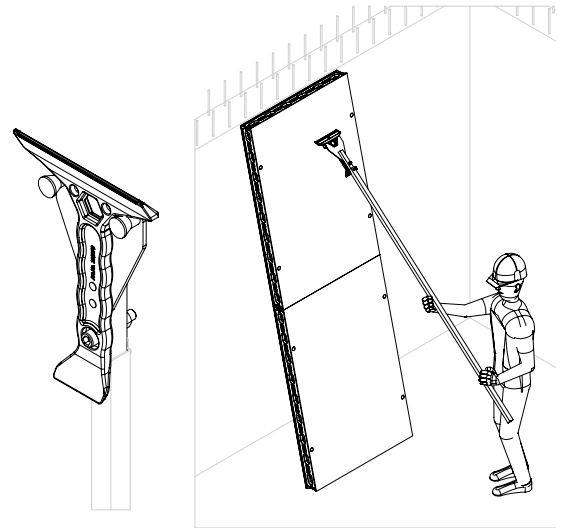

Fig. E1.05a

## Replacing the formlining



Do not use a hammer! If required, only use the DUO rubber hammer (9)!

### Replacing the formlining

(Fig. E1.06)

1. Remove all screws (10.8) that connect the formlining (10.5) and the frame (10.7).
2. Separate the formlining and frame.
3. Place the new formlining facing downwards on an even rectangular frame; use, e.g. square timbers (91), in order to avoid damage to the cambered formlining. The frame only supports the edge of the formlining, the inner area is free.
4. Position the panel frame on the bolts with fitting accuracy.
5. Press the panel frame onto the formlining with sufficient pressure until both parts are joined together.
6. Re-insert and tighten all screws.  
Start with the screws in the centre.  
Replace lost or damaged screws.  
Maximum torque: 1.5 Nm.

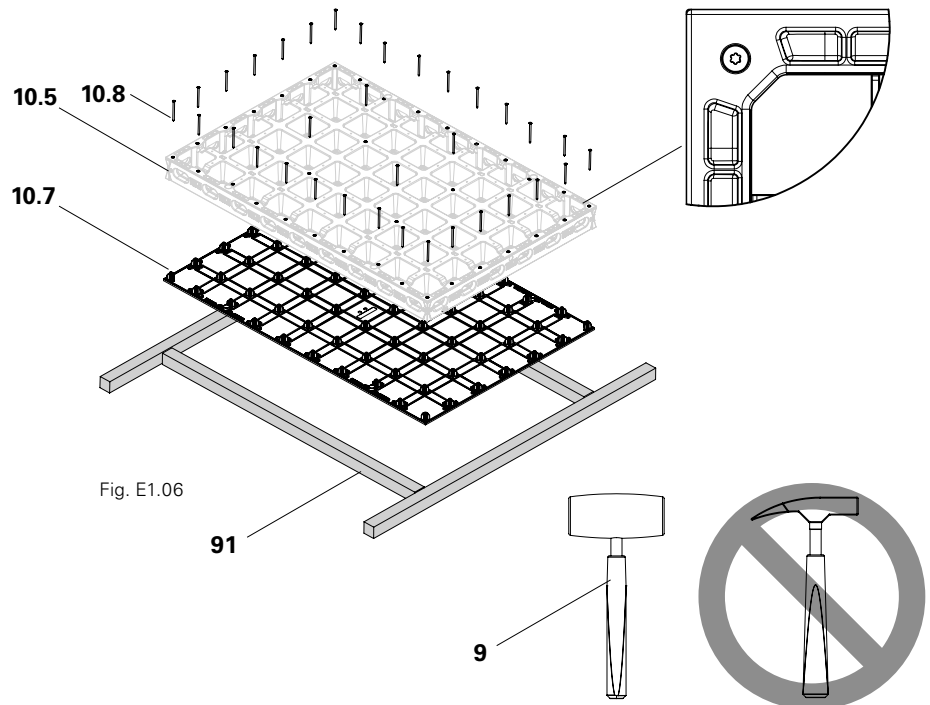

Fig. E1.06



Screws 5X90-TX25-VZ (10.8) according to ISO 14586 are available under art. no. 128272.

## DUO slab tables for the DFH prophead and DBH backpropping head

The DUO tables were created in order to:

Show the prop loads and planarity according to EN 18202 depending on the slab thickness.

### DUO slab with DFH prophead

Slab thickness d [m]	Load q* [kN/m <sup>2</sup> ]	Prop load [kN]	** Planarity according to EN 18202, Line
0.14	5.13	6.23	7
0.16	5.62	6.83	7
0.18	6.11	7.42	7
0.20	6.60	8.02	7
0.22	7.09	8.61	6
0.24	7.58	9.21	6
0.26	8.07	9.81	6
0.28	8.56	10.40	6
0.30	9.05	11.00	6

Tab. F1.01

\* Load according to EN 12812:

Dead load $Q_1$	=	0.2 kN/m <sup>2</sup>
Concrete load $Q_{2,b}$	=	24.5 kN/m <sup>3</sup> x d in m
Equivalent load: concreting $Q_4$	=	0.75 kN/m <sup>2</sup>
Equivalent load: working conditions $Q_{2,p}$	=	0.75 kN/m <sup>2</sup>
Total load Q	=	$Q_1 + Q_{2,b} + Q_{2,p} + Q_4$

\*\* Planarity according to EN 18202. Assuming perfect levelling.

## DUO slab with DBH backpropping head

Slab thickness d [m]	Load q* [kN/m <sup>2</sup> ]	Prop load [kN]	** Planarity according to EN 18202, Line
0.14	5.13	6.93	7
0.16	5.62	7.59	7
0.18	6.11	8.25	6
0.20	6.60	8.91	6
0.22	7.09	9.57	6
0.24	7.58	10.23	6
0.26	8.07	10.89	5
0.28	8.56	11.56	5
0.30	9.05	12.22	5

Tab. F1.02

- \* Load according to EN 12812:
- Dead load  $Q_1$  = 0.2 kN/m<sup>2</sup>
  - Concrete load  $Q_{2,b}$  = 24.5 kN/m<sup>3</sup> x d in m
  - Equivalent load: concreting  $Q_4$  = 0.75 kN/m<sup>2</sup>
  - Equivalent load: working conditions  $Q_{2,p}$  = 0.75 kN/m<sup>2</sup>
  - Total load Q =  $Q_1 + Q_{2,b} + Q_{2,p} + Q_4$
- \*\* Planarity according to EN 18202. Assuming perfect levelling.

Art no.	Weight [kg]		L [mm]
<b>Panels DP 135</b>			
128285	5.270	<b>Panel DP 135x15</b>	150
128284	9.370	<b>Panel DP 135x30</b>	300
128282	17.100	<b>Panel DP 135x60</b>	600
128280	24.900	<b>Panel DP 135x90</b>	900

Panel with 5 mm formlining.

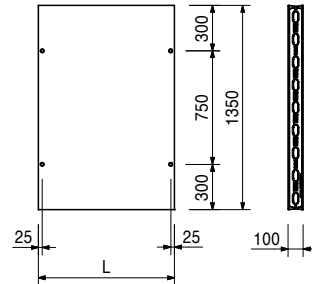
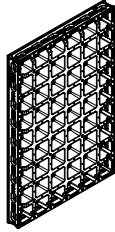

Art no.	Weight [kg]	
191002	24.800	<b>Panel DP 135x90-6</b>

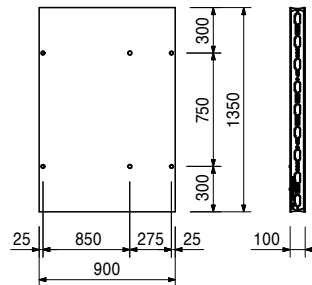
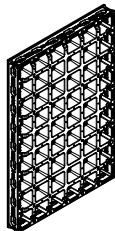

Art no.	Weight [kg]	
191003	17.100	<b>Panel DP 135x60-6</b>

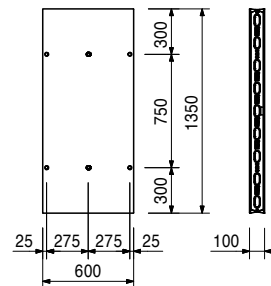
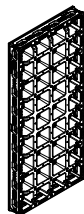

Art no.	Weight [kg]		B [mm]
128281	22.900	<b>Multi Panel DMP 135x75</b>	750

Panel with 5 mm formlining.  
Also for columns, stopends etc.

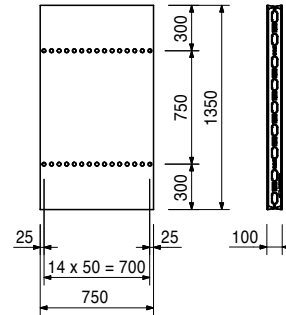
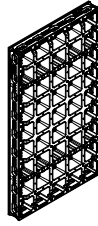

**Included in delivery**

128274 Plug DUO Ø20mm 26 pc

Art no.	Weight [kg]		B [mm]
128283	14.200	<b>Multi Panel DMP 135x45</b>	450

Panel with 5 mm formlining.  
Also for columns, stopends etc.

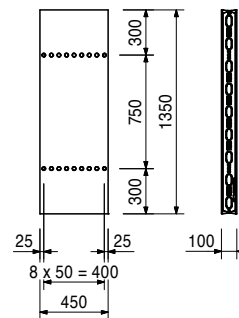
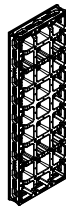

**Included in delivery**

128274 Plug DUO Ø20mm 14 pc

Art no.	Weight [kg]		
128286	5.110	<b>Corner DC 135x10</b>	

For 90° internal and external corners.

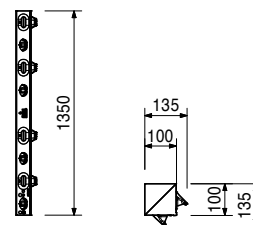

Art no.	Weight [kg]		L [mm]	X [mm]
<b>Wall Thickness Comp DWC 135</b>				
128287	2.850	<b>Wall Thickness Comp.DWC 135x 5</b>	50	127
128288	3.120	<b>Wall Thickness Comp.DWC 135x 6</b>	60	137
128289	3.390	<b>Wall Thickness Comp.DWC 135x 7</b>	70	147
128290	3.640	<b>Wall Thickness Comp.DWC 135x 8</b>	80	157
128291	3.900	<b>Wall Thickness Comp.DWC 135x 9</b>	90	167
128292	4.150	<b>Wall Thickness Comp.DWC 135x10</b>	100	177

For adjusting to wall thicknesses.

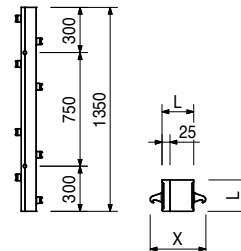

Art no.	Weight [kg]		B [mm]
<b>Filler Supports DFS 135</b>			
129979	1.430	<b>Filler Support 12 DFS 135</b>	12
128246	1.510	<b>Filler Support 15 DFS 135</b>	15
128245	1.390	<b>Filler Support 18 DFS 135</b>	18

For wall thickness compensation from 9 cm to 25 cm with 12 mm, 15 mm or 18 mm filler plate.

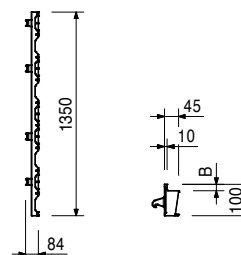

Art no.	Weight [kg]		L [mm]
<b>Panels DP 60</b>			
129842	2.430	<b>Panel DP 60x15</b>	150
129841	4.500	<b>Panel DP 60x30</b>	300
129839	8.160	<b>Panel DP 60x60</b>	600
129837	11.900	<b>Panel DP 60x90</b>	900

Panel with 5 mm formlining.

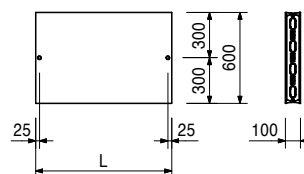
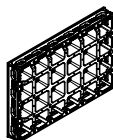

# DUO

Art no.	Weight [kg]	
129838	10.800	<b>Multi Panel DMP 60x75</b>

Panel with 5 mm formlining.  
Also for columns, stopends etc.

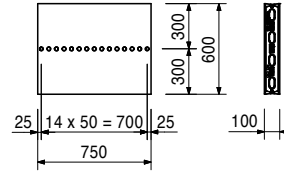
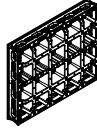

### Included in delivery

128274 Plug DUO Ø20mm 13 pc

Art no.	Weight [kg]	
129840	6.690	<b>Multi Panel DMP 60x45</b>

Panel with 5 mm formlining.  
Also for columns, stopends etc.

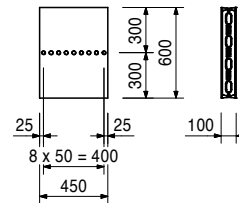

### Included in delivery

128274 Plug DUO Ø20mm 7 pc

Art no.	Weight [kg]	
129864	2.300	<b>Corner DC 60x10</b>

For 90° internal and external corners.

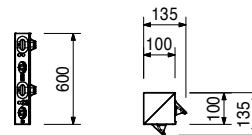

Art no.	Weight [kg]		L [mm]	X [mm]
		<b>Wall Thickness Comp.DWC 60</b>		
129879	1.310	<b>Wall Thickness Comp.DWC 60x 5</b>	50	127
129880	1.430	<b>Wall Thickness Comp.DWC 60x 6</b>	60	137
129881	1.560	<b>Wall Thickness Comp.DWC 60x 7</b>	70	147
129882	1.680	<b>Wall Thickness Comp.DWC 60x 8</b>	80	157
129883	1.800	<b>Wall Thickness Comp.DWC 60x 9</b>	90	167
129884	1.920	<b>Wall Thickness Comp.DWC 60x10</b>	100	177

For adjusting to wall thicknesses.

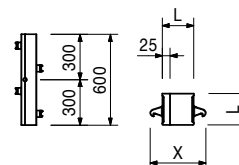

Art no.	Weight [kg]		B [mm]
<b>Filler Supports DFS 60</b>			
129980	0.658	<b>Filler Support 12 DFS 60</b>	12
129890	0.694	<b>Filler Support 15 DFS 60</b>	15
129889	0.641	<b>Filler Support 18 DFS 60</b>	18

For wall thickness compensation from 9 cm to 25 cm with 12 mm, 15 mm or 18 mm shim.

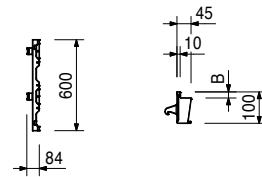

Art no.	Weight [kg]	
131205	0.984	<b>Accessory Bag DUO</b>

Accessory bag for clean and efficient storage on the construction site. Suitable for all small accessories such as connectors, corner connectors, etc. Lightweight and robust.

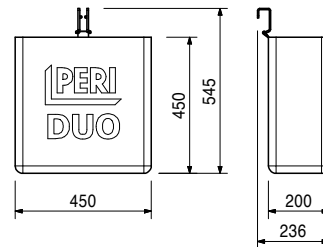
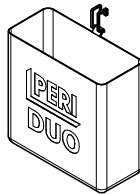

Art no.	Weight [kg]	
128247	0.160	<b>Coupler DUO</b>

For all connections of panels, corners and compensations for DUO.

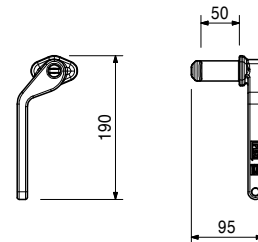

Art no.	Weight [kg]	
131240	0.553	<b>Steel Waler Connector DUO</b>

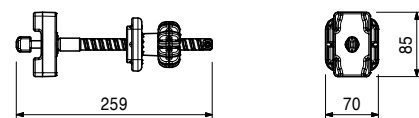
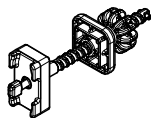

Art no.	Weight [kg]	
129550	0.012	<b>Special Panel Sleeve DUO 60-6</b>

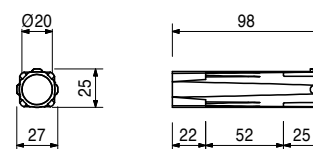
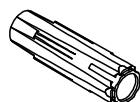

# DUO

Art no.	Weight [kg]	
128255	2.380	<b>Compensation Waler DUO 62</b>

For longitudinal compensation, height extensions and stopends with DUO. Maximum compensation width 25 mm.

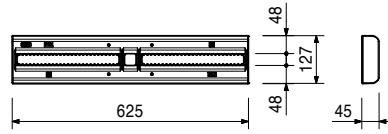
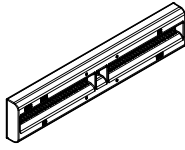

**Accessory (not included)**

- 128293 Tube Holder DUO
- 128256 Coupling Tie DUO

Art no.	Weight [kg]	
128293	0.502	<b>Tube Holder DUO</b>

For fixing Compensation Waler DUO 62 and Scaffold Tubes Ø 48 mm.

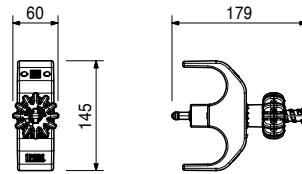

Art no.	Weight [kg]	
131245	0.866	<b>Timber Connector DUO</b>

For the fixation of Timbers 2 x 4" (nominal 1 - 1/2" x 3 - 1/2 real) and Metal Profiles 50 x 50 mm.

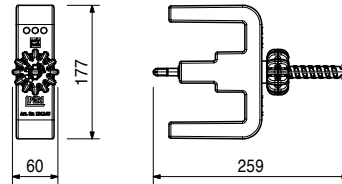
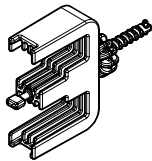

Art no.	Weight [kg]	
128256	0.068	<b>Coupling Tie DUO</b>

For connecting timber compensations up to 5 cm and for fixing Compensation Waler DUO 62 as stopend.

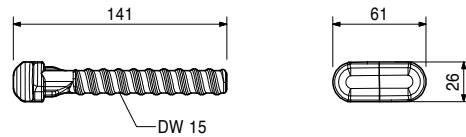
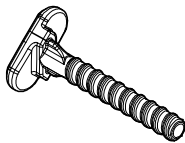

**Accessory (not included)**

- 128254 Grip DW15 DUO
- 030110 Wingnut Counterplate DW15 ga

# DUO

Art no. Weight [kg]

128254 0.076 **Grip DW15 DUO**

Accessory for Coupling Tie DUO.

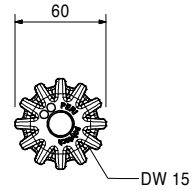
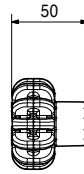
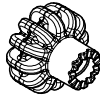

### Accessory (not included)

128256 Coupling Tie DUO

Art no. Weight [kg]

030130 0.318 **Cam Nut DW15 coat**

For anchoring with Tie Rod DW15 or B15.

### Notes

Permissible load 90.0 kN.

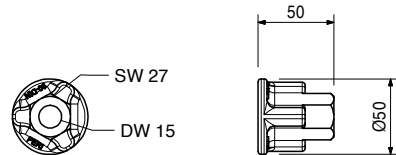
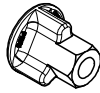

Art no. Weight [kg]

030110 0.799 **Wingnut Counterplate DW15 ga**

For anchoring with Tie Rod DW15 or B15.

### Notes

Permissible load 90.0 kN.

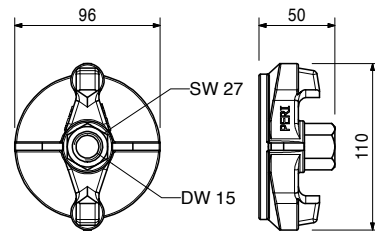

Art no. Weight [kg]

201004 1.660 **Wingnut Pivot Plate DW15 ga**

For anchoring with Tie Rod DW15 or B15.

With articulated, captive nut. Maximum inclination of anchor: +/- 8°.

### Notes

Wrench size AF27.

Permissible load 90,0 kN.

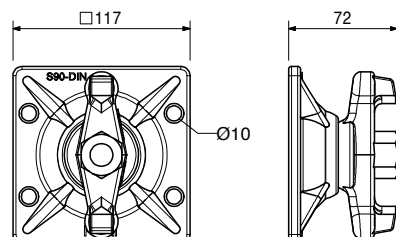
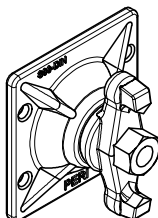

# DUO

Art no.	Weight [kg]	
128274	0.002	<b>Plug DUO Ø20mm</b>

For closing Ø 20 mm tie holes which are not required.

**Notes**

Delivery Unit 250 pieces.

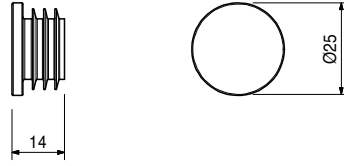

Art no.	Weight [kg]	
128294	0.907	<b>Brace Connector DUO</b>

For connecting push-pull props and kicker braces to DUO Panels.

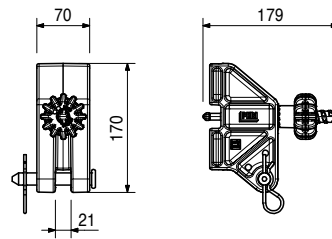
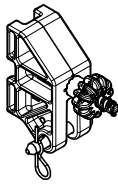

**Included in delivery**

- 018050 Pin Ø16x65/86mm ga 1 pc
- 018060 Cotter Pin 4/1 ga 1 pc

Art no.	Weight [kg]	
128257	3.560	<b>Scaffold Bracket DUO 70</b>

For assembling a working and concreting platform with DUO.

**Notes**

Permissible load 150.0 kg/m<sup>2</sup> with maximum influence width 1.80 m.

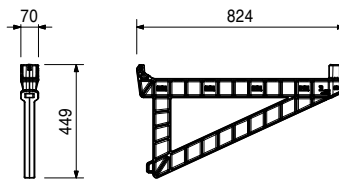

**Accessory (not included)**

- 117325 Post PP

Art no.	Weight [kg]	
131242	0.755	<b>Front Post Holder DUO</b>

For mounting a guardrail on DUO panels.

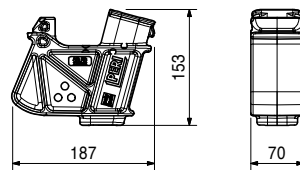
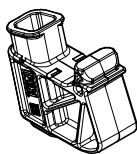

**Accessory (not included)**

- 117325 Post PP

# DUO

Art no.	Weight [kg]	
117325	4.270	<b>Post PP</b>

For the fixation of the Side-Mesh-Barriers.

**Notes**

Distance of posts with Side Mesh Barrier 260 max. 2.40 m.

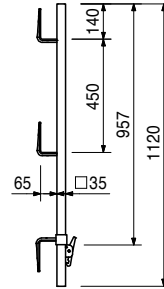

Art no.	Weight [kg]	
128295	1.040	<b>Corner Connector DUO</b>

For corner connection with columns and wall offsets.

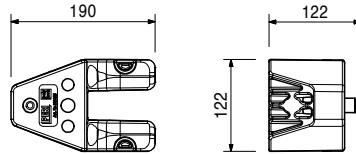
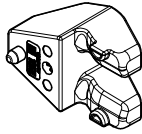

**Accessory (not included)**

- 030110 Wingnut Counterplate DW15 ga
- 128265 Corner Tie DUO

Art no.	Weight [kg]	
128265	0.871	<b>Corner Tie DUO</b>

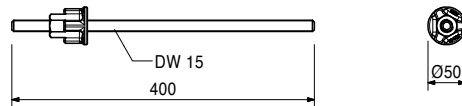
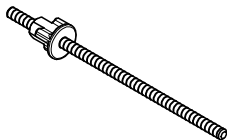

**Accessory (not included)**

- 128295 Corner Connector DUO
- 030110 Wingnut Counterplate DW15 ga

**Included in delivery**

- 127167 Tie Rod DW15 0.4m coat 1 pc
- 030130 Cam Nut DW15 coat 1 pc

Art no.	Weight [kg]	
128260	0.642	<b>Chamfer Strip DUO 135</b>

For DUO Column.  
Edge length 15 x 15 mm.

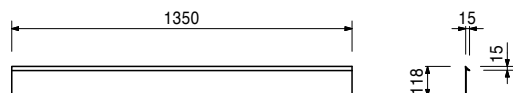
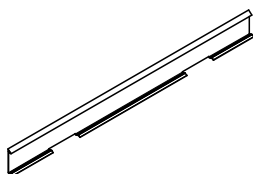

# DUO

Art no.	Weight [kg]	
129557	0.284	<b>Chamfer Strip DUO 60</b>

For DUO Column.  
Edge length 15 x 15 mm.

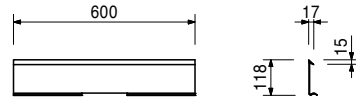
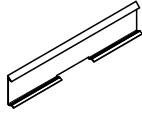

Art no.	Weight [kg]	
128298	0.909	<b>Fix Head DFH</b>

With clip retention. Supports DUO Panels as slab formwork.

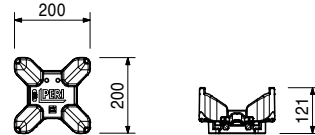
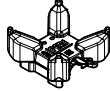

Art no.	Weight [kg]	
129862	1.580	<b>Back Propping Head DBH</b>

With clip closure. In conjunction with filler panels, ceiling props can be placed for post-support.

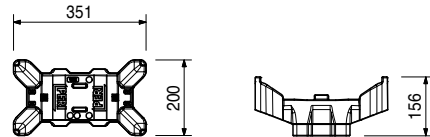
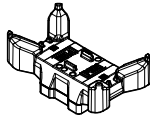

Art no.	Weight [kg]		L [mm]
<b>Filler Panels DFP 15</b>			
129861	0.402	<b>Filler Panel DFP 15x 5</b>	5
129860	0.544	<b>Filler Panel DFP 15x10</b>	10
129859	0.638	<b>Filler Panel DFP 15x15</b>	15
129858	1.470	<b>Filler Panel DFP 15x45</b>	45
129857	1.940	<b>Filler Panel DFP 15x60</b>	60
129856	2.470	<b>Filler Panel DFP 15x75</b>	75
129855	2.930	<b>Filler Panel DFP 15x90</b>	90

For use as extension panels for vertical formwork situations or as filler panels for post-support of slab formwork.

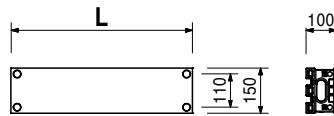
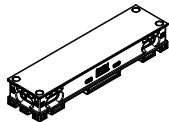

Art no.	Weight [kg]	
128263	2.950	<b>Wall Holder DUO 82</b>

For horizontal anchoring on the wall. Attach to every third DUO Panel as slab formwork.

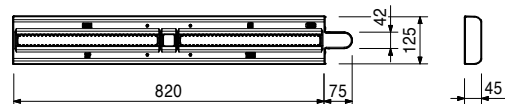
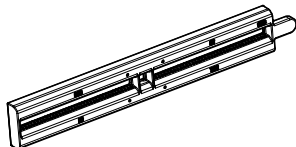

# DUO

Art no.	Weight [kg]	
128299	2.470	<b>Shuttering Aid DUO</b>

For forming of DUO Slabs.

**Notes**

Adjustable in 7.5 cm increments.

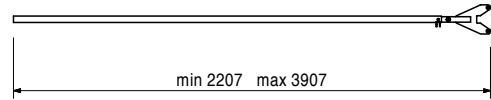
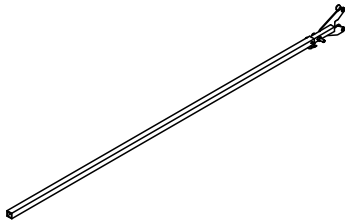

Art no.	Weight [kg]		L [mm]
104278	0.067	<b>Screw ISO4762-M12x60-8.8-ga</b>	60

**Notes**

Wrench size AF10.

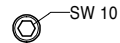
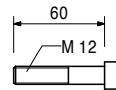

Art no.	Weight [kg]	
104526	0.017	<b>Nut ISO4032-M12-8</b>

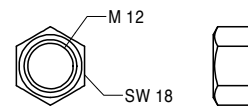
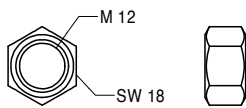

Art no.	Weight [kg]	
132440	1.160	<b>Stripping Bar DUO</b>

For simple stripping of DUO panels.

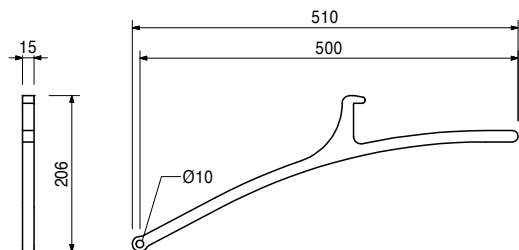
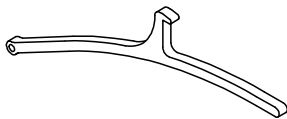

Art no.	Weight [kg]	
128264	0.457	<b>Slab Guardrail Holder DUO</b>

For assembling a guardrail on DUO Panels as slab formwork.

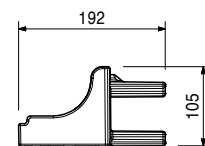
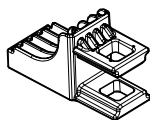

**Accessory (not included)**

061260 Guardrail Post SGP

Art no.	Weight [kg]	
061260	6.150	<b>Guardrail Post SGP</b>

As guardrail for different systems.

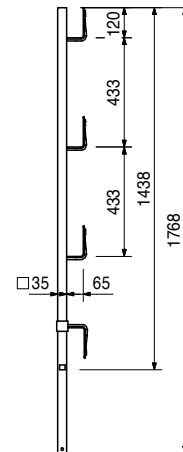

Art no.	Weight [kg]	
065066	14.800	<b>End Guardrail Frame 55</b>

End guardrail for clamping to all PERI Scaffold Platforms and Climbing Systems.

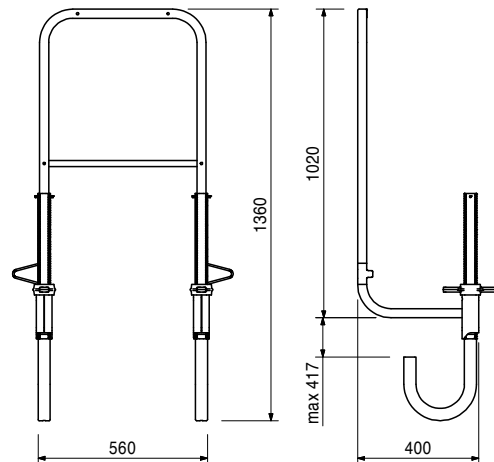
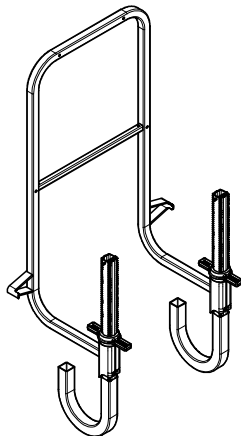

Art no.	Weight [kg]	
128296	0.948	<b>Crane Eye DUO</b>

For transporting DUO Panels.

**Notes**

Follow Instructions for Use!  
Permissible load capacity 200.0 kg.

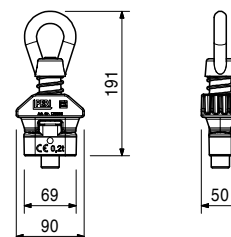

# DUO

Art no.	Weight [kg]	
128275	0.011	<b>Stacking Aid DUO</b>

Prevents panels sliding and protects the formlining against damage.

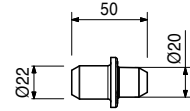

Art no.	Weight [kg]	
018050	0.171	<b>Pin Ø16x65/86mm ga</b>

For different connections.

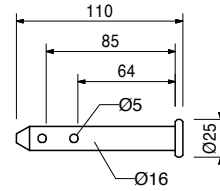
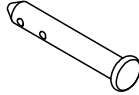

**Accessory (not included)**

018060 Cotter Pin 4/1 ga

Art no.	Weight [kg]	
018060	0.014	<b>Cotter Pin 4/1 ga</b>

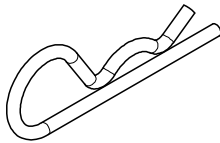

Art no.	Weight [kg]		L [mm]
<b>Extension Supports DES</b>			
129809	0.387	<b>Extension Support DES 12</b>	87
129810	0.378	<b>Extension Support DES 15</b>	84
129811	0.369	<b>Extension Support DES 18</b>	81

Extensions with filler plywood.

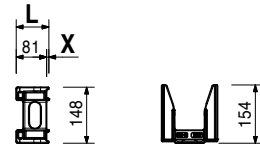

Art no.	Weight [kg]	
129976	0.567	<b>Frame Holder DUO</b>

For fixing panels on the ground and for grid-independent anchoring outside of the panel, especially for foundations and height extensions.

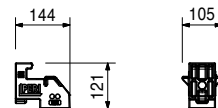

Art no. Weight [kg]

128278 0.372 **Cleaning Device DUO**

For cleaning DUO formlining and panel edge profiles or tighten wingnut plates.

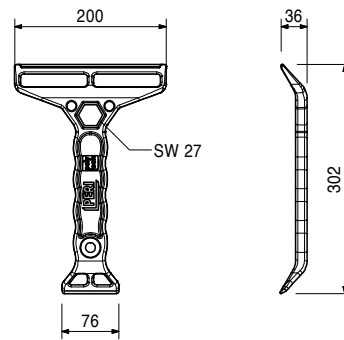
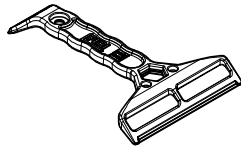

Art no. Weight [kg]

128302 3.710 **Stacking Device DUO**

For transporting material gently. For stacking and transporting 3 - 10 DUO panels.

### Notes

Permissible load 75.0 kg per stanchion, 300.0 kg per stack.

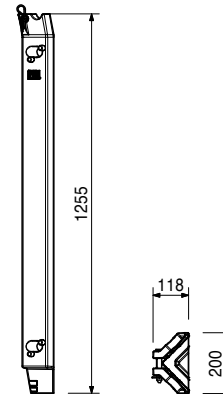

Art no. Weight [kg]

128276 1.240 **Stacking Device Wheel DUO**

For horizontal transport on the construction site.  
For moving filled stacking stanchions.

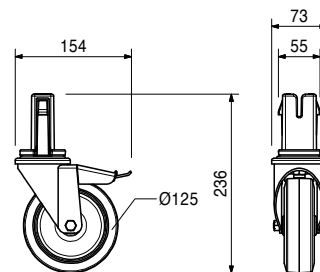
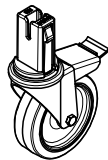

Art no. Weight [kg]

133526 3.500 **PP Welding Wire D 4**

For repairing scratches on the DUO formlining.

# DUO

Art no.	Weight [kg]	
132104	0.006	<b>Repair Plug DUO</b>

For repairing the DUO formwork skin.

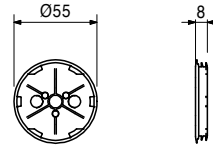

Art no.	Weight [kg]	
<b>Suitcase Repair Kits DUO HLP</b>		
133906	8.500	<b>Suitcase Repair Kit DUO wo.HLP</b>
128708	9.500	<b>Suitcase Repair Kit DUO w. HLP</b>

For quick and easy repair of DUO formlining.

**Notes**

- Complete with
- 1 pc. Hot air gun
- 1 pc. 133526 PP welding rod Ø 4 mm
- 16 pcs 132104 Repair plug Ø 50 mm
- 1 pc. scraper
- 1 pc. Drill Ø 50 mm
- 1 pc. repair manual

Article 133906 Case repair kit DUO (for USA) without hot air gun

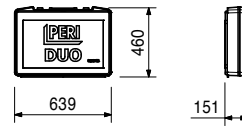
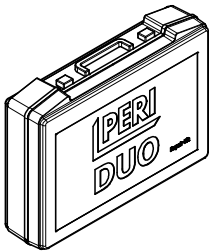

Art no.	Weight [kg]	
131139	0.725	<b>Shoring Adaptor DUO</b>

For mounting DFH and DBH heads on end plates of dimensions > 120 x 120 mm to 150 x 150 mm and UJB 38-50/30 foot spindle.

**Notes**

Permissible load: 12.2 kN.

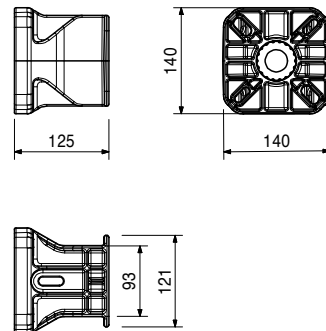
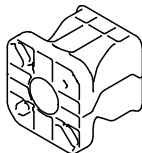

# DUO

Art no.    Weight [kg]

131182	0.241	<b>LIWA Adaptor DUO</b>
--------	-------	-------------------------

For connecting Articulated Corner LIWA.

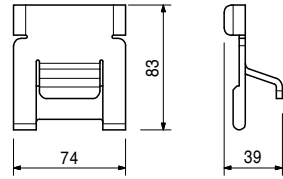
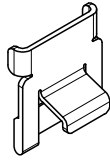

Art no.    Weight [kg]

131241	0.395	<b>Domino Adapter DUO</b>
--------	-------	---------------------------

For connecting Articulated Corner DOMINO.

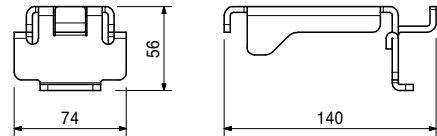
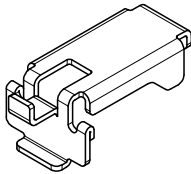

Art no.    Weight [kg]

131239	0.124	<b>Foundation Tie Clamp DUO</b>
--------	-------	---------------------------------

Accessory for Brace Connector DUO. For anchoring foundation formwork in combination with perforated foundation tie.

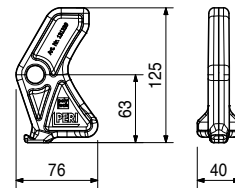

**Accessory (not included)**

128294    Brace Connector DUO

Art no.    Weight [kg]

023020	16.900	<b>Perforated Foundation Tie 25m</b>
--------	--------	--------------------------------------

For use with Foundation Tie Clamp MX/TR, DOMINO, LIWA and HANDSET.

**Notes**

Permissible tension force 12.9 kN.

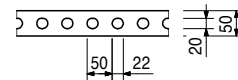
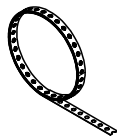

Art no.    Weight [kg]

131061	0.804	<b>Girder Rack End Section DUO</b>
--------	-------	------------------------------------

Adapter for beams with belt width 80 mm.  
For forming beams with beam tooth bar and DUO panel

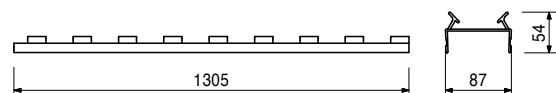
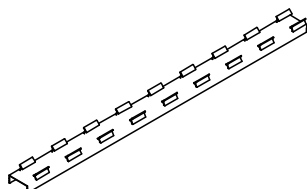

# DUO

Art no.	Weight [kg]	
133266	0.551	<b>Girder Rack Centre Section DUO</b>

Adapter for girders with 80 mm belt width. For shuttering around girders with a carrier rack and DUO panels.

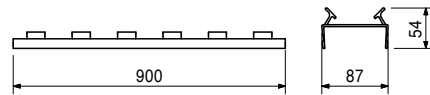
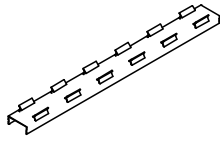

Art no.	Weight [kg]	
131225	2.080	<b>Hook Strap SB/DUO</b>

For the fixation of Brace Frame SB to Compensation Waler DUO 62.

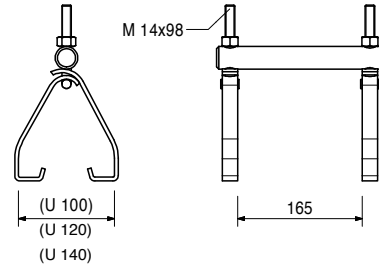
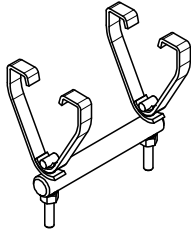

Art no.	Weight [kg]	
126299	0.466	<b>Slab Stopend Angle Plastic</b>

### Notes

See data sheet!

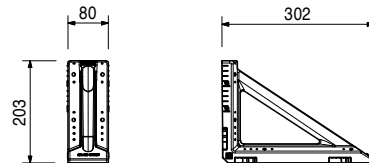
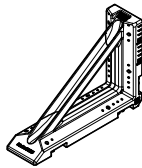

Art no.	Weight [kg]		L [mm]
<b>Formlinings DP 135</b>			
128233	1.250	<b>Formlining DP 135x15</b>	150
128232	2.460	<b>Formlining DP 135x30</b>	300
128230	4.870	<b>Formlining DP 135x60</b>	600
128228	7.070	<b>Formlining DP 135x90</b>	900

5 mm formlining for replacement.

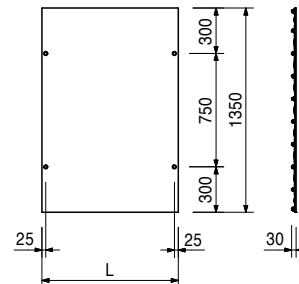
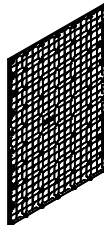

### Accessory (not included)

128272 Screw ISO14586ST5.5x90-TX25-ga

# DUO

Art no. Weight [kg]

128229 6.040 **Multi Formlining DMP 135x75**

5 mm formlining for replacement.

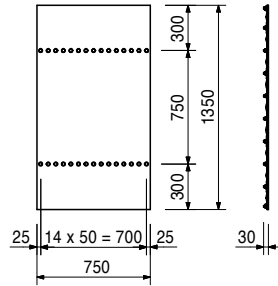
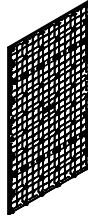

### Accessory (not included)

128272 Screw ISO14586ST5.5x90-TX25-ga

Art no. Weight [kg]

128231 3.580 **Multi Formlining DMP 135x45**

5 mm formlining for replacement.

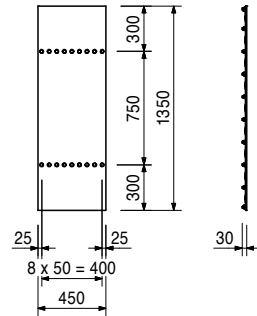

Art no. Weight [kg]

### Formlinings DP 60

L [mm]

129848	0.562	<b>Formlining DP 60x15</b>	150
129847	1.090	<b>Formlining DP 60x30</b>	300
129845	2.180	<b>Formlining DP 60x60</b>	600
129843	3.300	<b>Formlining DP 60x90</b>	900

5 mm formlining for replacement.

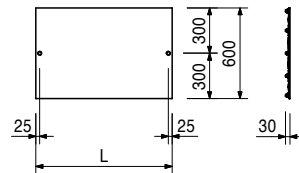
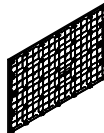

Art no. Weight [kg]

129844 2.700 **Multi Formlining DMP 60x75**

5 mm formlining for replacement.

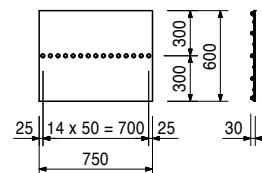
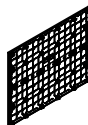

# DUO

Art no.	Weight [kg]	
129846	1.600	<b>Multi Formlining DMP 60x45</b>

5 mm formlining for replacement.

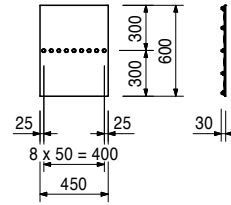

Art no.	Weight [kg]	
117466	10.600	<b>Push-Pull Prop RS 210 ga</b>

Extension length L = 1.30 – 2.10 m.  
For aligning PERI Formwork Systems and precast concrete elements.

### Notes

Permissible load see Instructions for Assembly and Use.

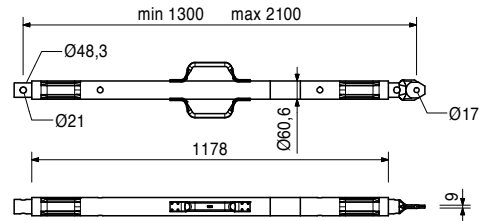
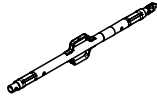

Art no.	Weight [kg]	
118238	12.100	<b>Push-Pull Prop RS 260 ga</b>

Extension length L = 2.30 – 2.60 m.  
For aligning PERI Formwork Systems and precast concrete elements.

### Notes

Permissible load see Instructions for Assembly and Use.

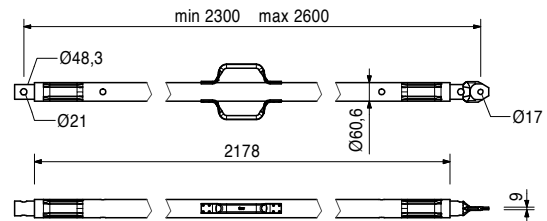
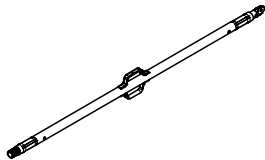

Art no.	Weight [kg]	
117467	15.500	<b>Push-Pull Prop RS 300 ga</b>

Extension length L = 1.90 – 3.00 m.  
For aligning PERI Formwork Systems and precast concrete elements.

### Notes

Permissible load see Instructions for Assembly and Use.

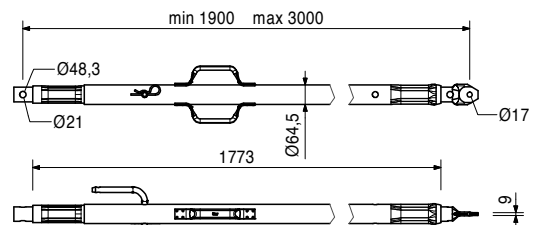
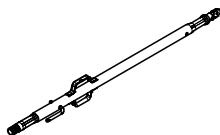

Art no.	Weight [kg]	
117468	23.000	<b>Push-Pull Prop RS 450 ga</b>

Extension length L = 2.80 – 4.50 m.  
 For aligning PERI Formwork Systems and precast concrete elements.

**Notes**

Permissible load see Instructions for Assembly and Use.

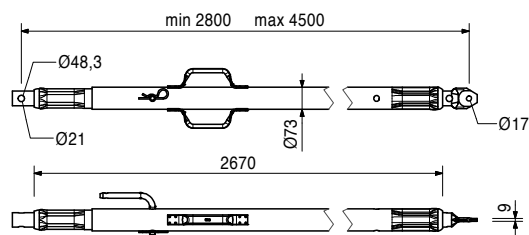
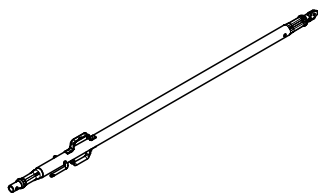

Art no.	Weight [kg]	
126666	3.040	<b>Base Plate-3 f. RS 210-1400</b>

For assembly of Push-Pull Props RS 210, 260, 300, 450, 650, 1000 and 1400.

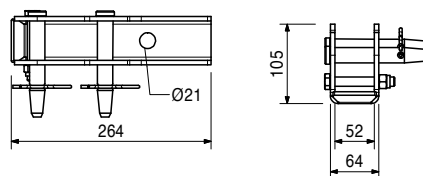
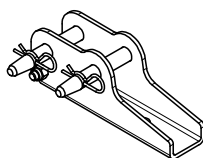

**Accessory (not included)**

124777 Anchor Bolt AF24 Ø14/20x130 TG

**Included in delivery**

- 113063 Screw ISO4014-M12x80-8.8-ga 1 pc
- 113064 Hex-Nut ISO7040-M12-8-ga 1 pc
- 105400 Pin Ø20x140mm ga 2 pc
- 018060 Cotter Pin 4/1 ga 2 pc

Art no.	Weight [kg]	
113397	1.600	<b>Spindle Handle RSS/AV</b>

Spindle handle for screwing on Push-pull-Props RSS I, RSS II and Kickers AV 210 and AV RSS III.

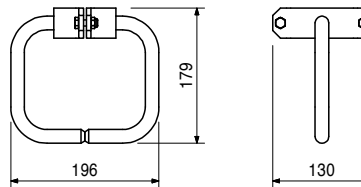
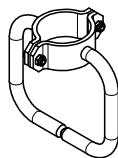

**Included in delivery**

- 722342 Screw ISO4017-M8x25-8.8-ga 2 pc
- 711071 Nut ISO7040-M8-8-ga 2 pc

For aligning PERI Formwork Systems.

**Notes**

Permissible load see PERI Design Tables.

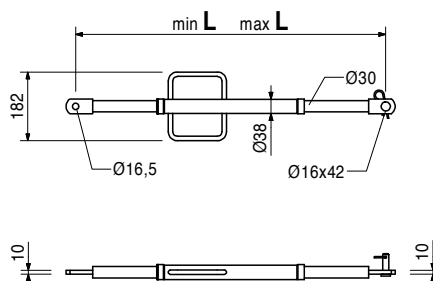
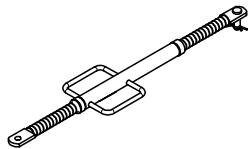

**Included in delivery**

- 027170 Pin Ø16x42mm ga 1 pc
- 018060 Cotter Pin 4/1 ga 1 pc

Art no.	Weight [kg]		D [mm]	L [mm]	min. L [mm]	max. L [mm]
028110	4.850	<b>Kicker AV 140</b>	2000	250	1080	1400

Extension length L = 1.08 - 1.40 m.  
For aligning PERI Formwork Systems.

**Notes**

Permissible load see PERI Design Tables.

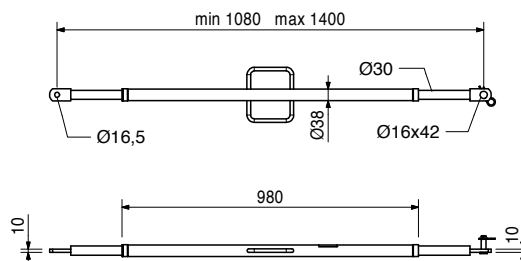
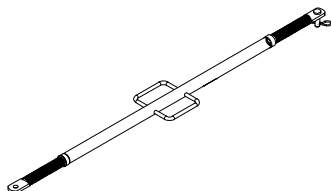

**Included in delivery**

- 027170 Pin Ø16x42mm ga 1 pc
- 018060 Cotter Pin 4/1 ga 1 pc

Art no.	Weight [kg]	
124777	0.210	<b>Anchor Bolt AF24 Ø14/20x130 TG</b>

For temporary attachment of construction site facilities in concrete.

**Notes**

Take the PERI Data Sheet into consideration!  
Hole Ø 14 mm.

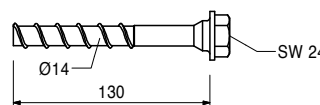
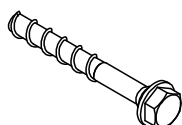

Art no.    Weight [kg]

130444    78.000    **Stripping Cart-2 Alu**

Mobile working scaffold. Height-adjustable in 25 cm increments. Platform height: max. 2.00 m.

### Notes

Follow Instruction for Use!  
Permissible load 100.0 kg/m<sup>2</sup>.

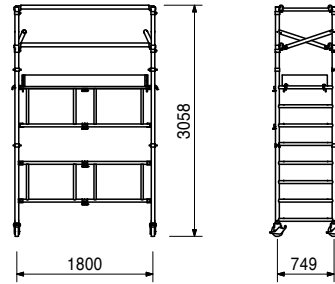
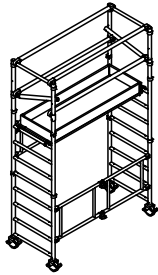



**PERI Ltd**  
**Formwork Scaffolding Engineering**  
Market Harborough Road  
Clifton upon Dunsmore  
Rugby  
CV23 0AN  
+44 (0)1788 861600  
info@peri.ltd.uk  
www.peri.ltd.uk